



PALAZZANI PROJECT



index



track pag 6



mis pag 52



flap pag 102



track termo pag 26



digit 2 pag 68



elettronico gear pag 110



click pag 30



digit 2 termo pag 80



elettronico digit pag 114



click termo pag 48



pin pag 88



temporizzato pag 128

track

pag 6

track termostatico
thermostatic mixer

pag 26

click

pag 30

click termostatico
thermostatic mixer

pag 48

mis

pag 52

digit 2

pag 68

digit 2 termostatico
thermostatic mixer

pag 80

pin

pag 88

flap

pag 102

rubinetti elettronici
electronic taps

pag 108

gear

pag 110

digit

pag 114

rubinetti temporizzati
timed taps

pag 128

index



gosh pag 132



yell pag 134



drive pag 136



pix pag 137



band pag 138



band pag 140



digit pag 144



kubik pag 146

sistemi doccia
shower systems

pag 130

gosh

pag 132

yell

pag 134

drive

pag 136

pix

pag 137

band

pag 138

soffioni doccia in ceramica

pag 142

digit

pag 144

kubik

pag 146

cucina
kitchen

pag 148

ceramica plavisdesign
ceramics

pag 154

docce, saliscendi,
accessori e ricambi
showers, sliderail, accessories, spare parts

pag 184

l'azienda
the company

pag 202

indice per codice
index by code

pag 212



cucina pag 148



ceramica pag 154

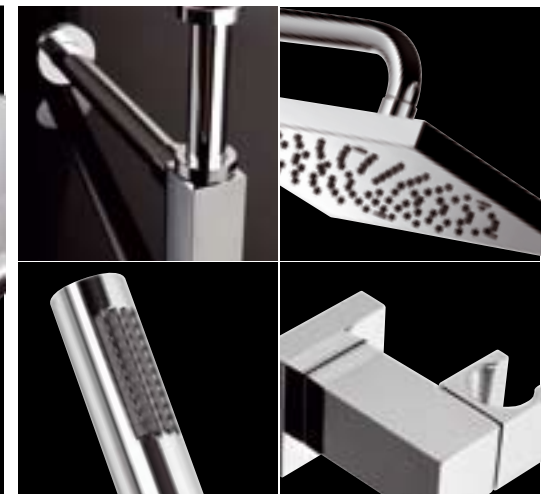

docce/ricambi pag 184

track



finiture disponibili _____
available finishes _____
finition disponibles _____
verfügbare Farben _____
acabados disponibles _____

10 Cromo - Chrome
Chromé - Chrom



track



Miscelatore monocomando per lavabo con scarico 1" 1/4, tappo a copertura totale.
 Single control mixer for washbasin, with pop up waste 1" 1/4, total covering plug.
 Mitigeur monocommande de lavabo, vidage 1" 1/4 avec bouchon à couverture totale.
 Waschtisch Einhebelmischer mit Ablaufgarnitur 1" 1/4, komplett deckender Ventildeckel.
 Mezclador monomando para lavabo con desagüe 1" 1/4 y tapón a cobertura total.

l/m	6	8	11	13	15
Kg/cm ²	0,5	1	2	3	4
10 € 245,00					

093010

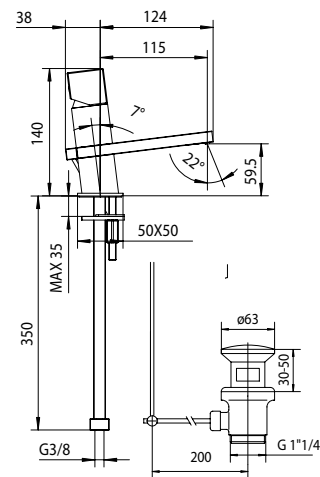
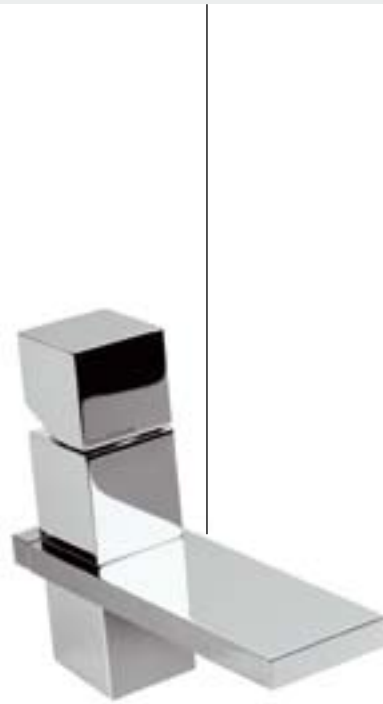

Miscelatore monocomando per lavabo senza scarico.
 Single control mixer for washbasin without waste.
 Mitigeur monocommande de lavabo sans vidage.
 Waschtisch Einhebelmischer ohne Ablaufgarnitur.
 Mezclador monomando para lavabo sin desagüe.

l/m	6	8	11	13	15
Kg/cm ²	0,5	1	2	3	4
10 € 224,00					

093011

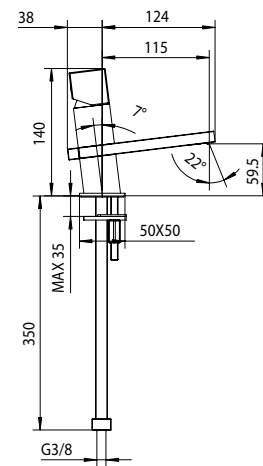

Miscelatore monocomando "midi" per lavabo con scarico 1" 1/4, tappo a copertura totale.
 "Midi" single control mixer for washbasin, with pop up waste 1" 1/4, total covering plug.
 Mitigeur monocommande "midi" de lavabo, vidage 1" 1/4 avec bouchon à couverture totale.
 "Midi" Waschtisch Einhebelmischer mit Ablaufgarnitur 1" 1/4, komplett deckender Ventildeckel.
 Mezclador monomando "midi" para lavabo con desagüe 1" 1/4 y tapón a cobertura total.

l/m	6	8	11	13	15
Kg/cm ²	0,5	1	2	3	4
10 € 265,00					

093085

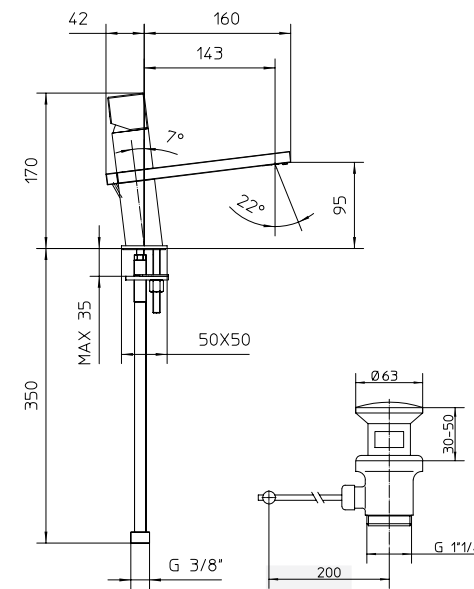

Miscelatore monocomando "midi" per lavabo senza scarico.
 "Midi" single control mixer for washbasin, without waste.
 Mitigeur monocommande "midi" de lavabo, sans vidage.
 "Midi" Waschtisch Einhebelmischer ohne Ablaufgarnitur.
 Mezclador monomando "midi" para lavabo sin desagüe.

l/m	6	8	11	13	15
Kg/cm ²	0,5	1	2	3	4
10 € 230,00					

093086

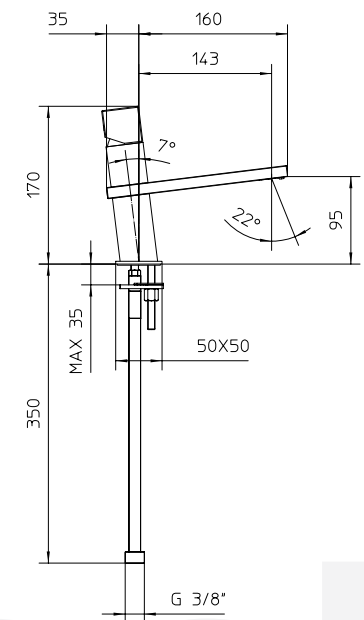

Miscelatore monocomando "midi" per lavabo con scarico Click-Clack, bocca prolungata 186 mm.

"Midi" single control mixer for washbasin, Click-Clack waste, extended spout 186 mm.

Mitigeur monocommande "midi" de lavabo, avec vidage Click-Clack, bec 186 mm.

"Midi" Waschtisch Einhebelmischer mit Click-Clack Ablaufgarnitur, Auslauf 186 mm.

Mezclador monomando "midi" para lavabo, con desagüe Click-Clack, caño prolongado mm 186.

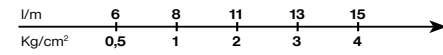

10 € 285,00

Miscelatore monocomando "midi" per lavabo senza scarico, bocca prolungata 186 mm.

"Midi" single control mixer for washbasin, without waste, extended spout 186 mm.

Mitigeur monocommande "midi" de lavabo, sans vidage, bec 186 mm.

"Midi" Waschtisch Einhebelmischer, Auslauf 186 mm, ohne Ablaufgarnitur.

Mezclador monomando "midi" para lavabo, sin desagüe, caño prolongado mm 186.

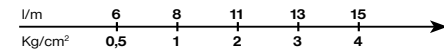

10 € 250,00

093087

093088

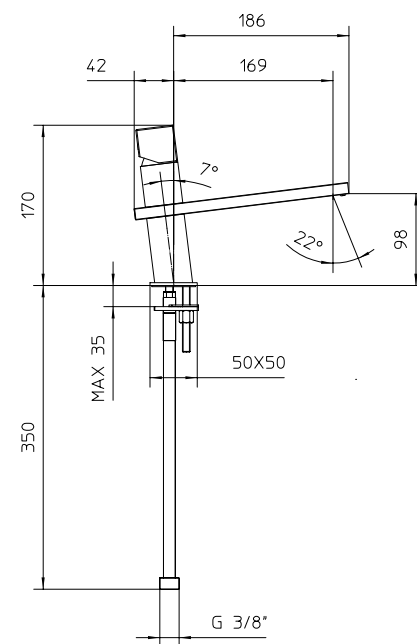
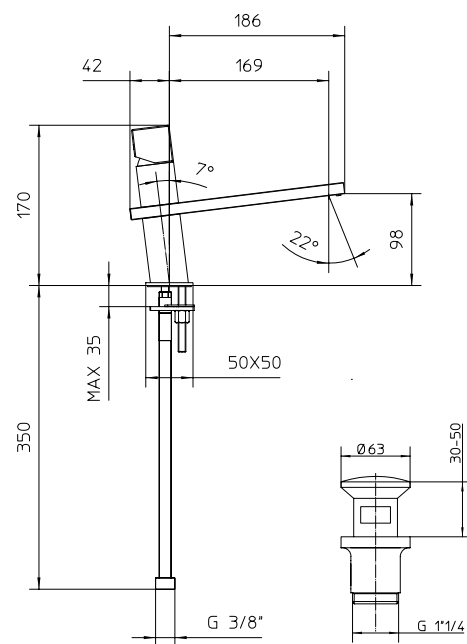

Miscelatore monocomando alto per lavabo con scarico 1" 1/4 Click-Clack.

Tall single control mixer for washbasin, Click-Clack waste 1" 1/4.

Mitigeur monocommande haut de lavabo, avec vidage Click-Clack 1" 1/4.

Hoch Waschtisch Einhebelmischer mit Click-Clack Ablaufgarnitur 1" 1/4.

Mezclador monomando alto para lavabo con desagüe Click-Clack 1" 1/4.

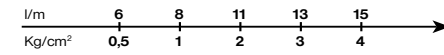

10 € 330,00

Miscelatore monocomando alto per lavabo senza scarico.

Tall single control mixer for washbasin, without waste.

Mitigeur monocommande haut de lavabo, sans vidage.

Hoch Waschtisch Einhebelmischer ohne Ablaufgarnitur.

Mezclador monomando alto para lavabo, sin desagüe.

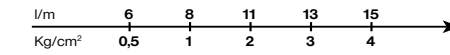

10 € 295,00

093077

093018

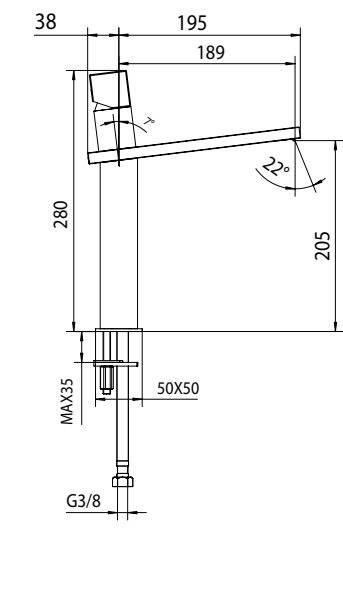
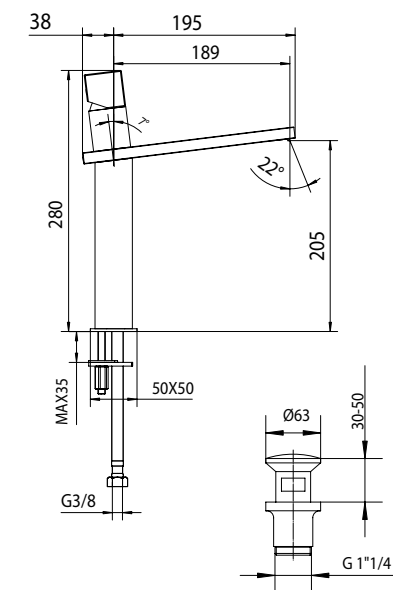

Miscelatore monocomando super-alto per lavabo con scarico 1" 1/4 Click-Clack.
 Super-high single control mixer for washbasin Click-Clack waste 1" 1/4.
 Mitigeur monocommande super-haut de lavabo, avec vidage Click-Clack 1" 1/4.
 Super-Hoch Waschtisch Einhebelmischer mit Click-Clack Ablaufgarnitur 1" 1/4.
 Mezclador monomando super-alto para lavabo, con desagüe Click-Clack 1" 1/4.

Miscelatore monocomando super-alto per lavabo, senza scarico.
 Super-high single control mixer for washbasin, without waste.
 Mitigeur monocommande super-haut de lavabo, sans vidage.
 Super-Hoch Waschtisch Einhebelmischer ohne Ablaufgarnitur.
 Mezclador monomando super-alto para lavabo, sin desagüe.

l/m	6	8	11	13	15
Kg/cm ²	0,5	1	2	3	4
10 € 390,00					

l/m	6	8	11	13	15
Kg/cm ²	0,5	1	2	3	4
10 € 355,00					

093079

093080

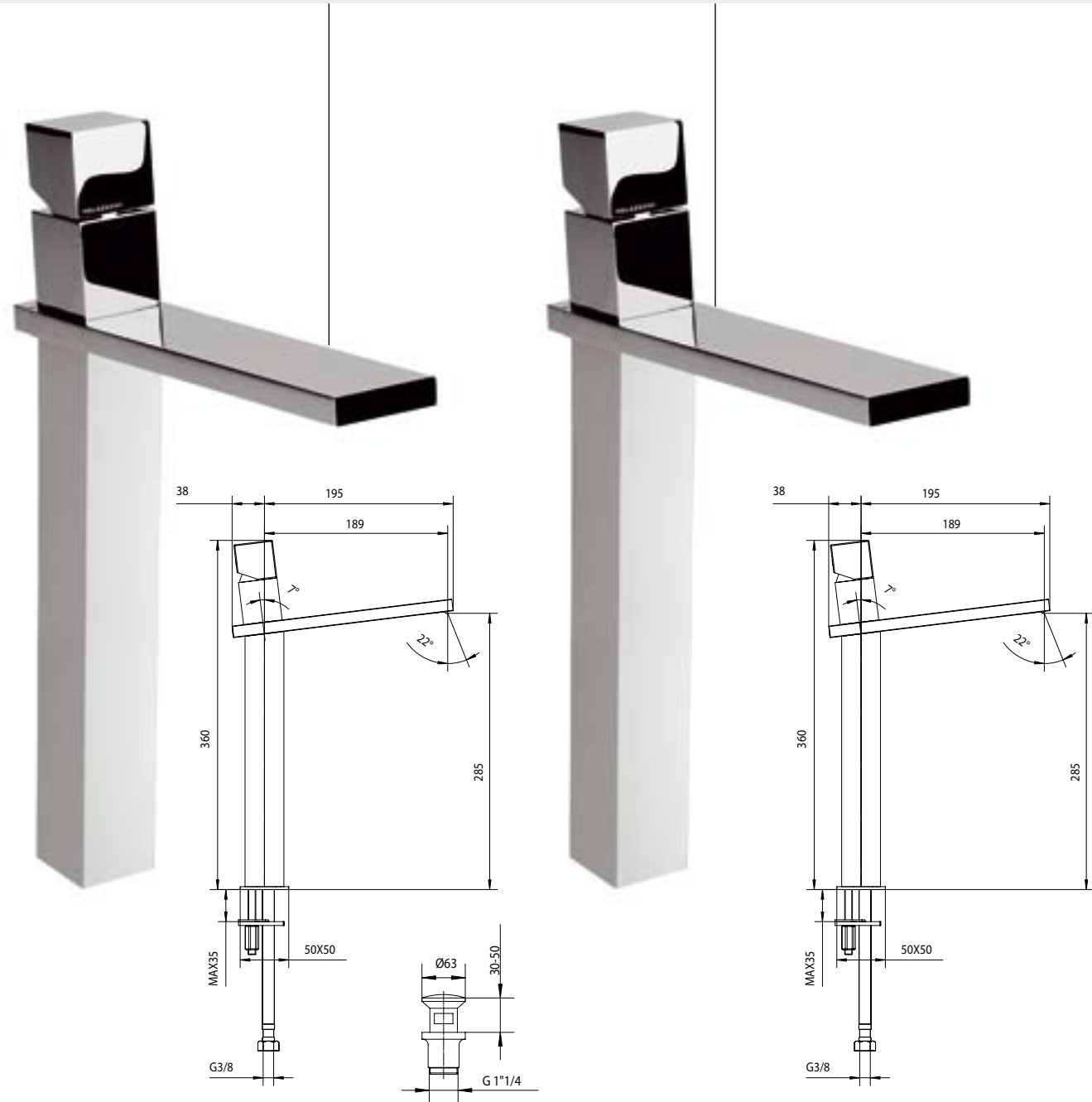

Miscelatore monocomando per bidet con scarico 1" 1/4, tappo a copertura totale.
 Single control mixer for bidet, with pop up waste 1" 1/4, total covering plug.
 Mitigeur monocommande de bidet, vidage 1" 1/4 avec bouchon à couverture totale.
 Bidet Einhebelmischer, Ablaufgarnitur 1" 1/4, komplett deckender Ventildeckel.
 Mezclador monomando para bidet con desagüe 1" 1/4 y tapón a cobertura total.

Miscelatore monocomando per bidet senza scarico.
 Single control mixer for bidet, without waste.
 Mitigeur monocommande de bidet, sans vidage.
 Bidet Einhebelmischer ohne Ablaufgarnitur.
 Mezclador monomando para bidet sin desagüe.

l/m	6	8	11	13	15
Kg/cm ²	0,5	1	2	3	4
10 € 259,00					

l/m	6	8	11	13	15
Kg/cm ²	0,5	1	2	3	4
10 € 238,00					

094010

094011

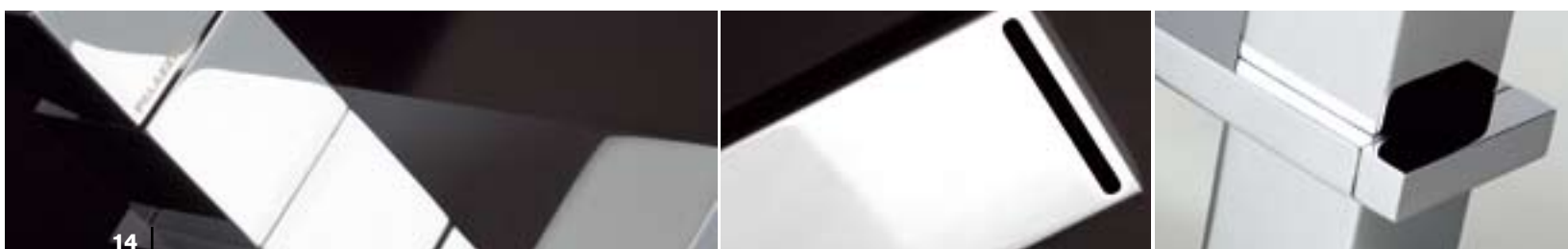
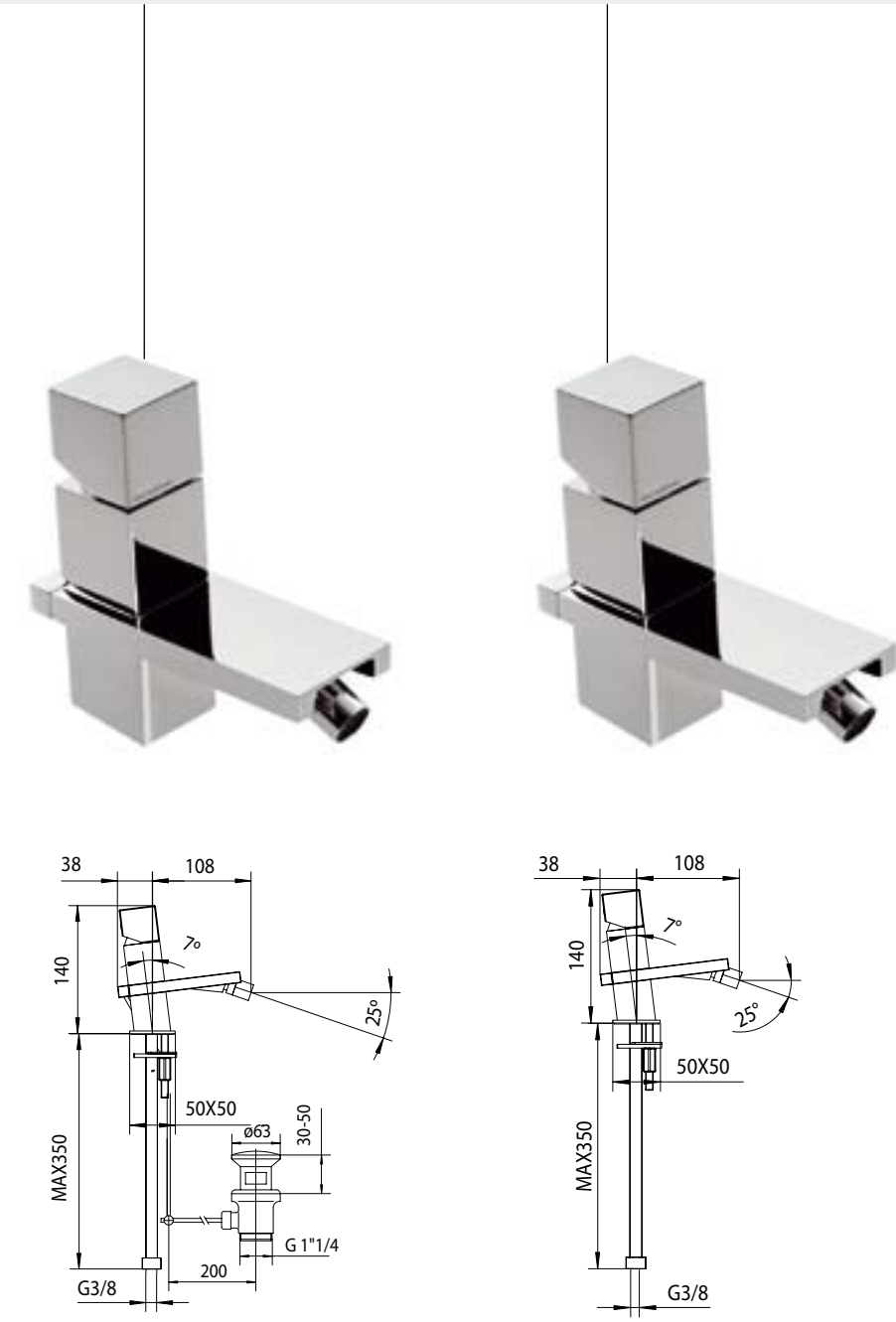

Miscelatore monocomando per vasca con deviatore, supporto doccia integrato, supporto doccia murale, flessibile Gliss 1,5 m e doccia.

Wall mounted bath-shower mixer, with diverter, built-in shower bracket, wall mounted swivel bracket with Gliss flexible tube 1,5 m and handshower.

Mitigeur monocommande de bain-douche avec support douche incorporé, flexible Gliss 1,5 m, douchette et support mural orientable.

Bade-Einhebelmischer, Aufputz mit eingebautem Brausehalter mit Gliss Brause-schlauch 1,5 m, Handbrause und verstellbarer Brausehalter.

Mezclador monomando para bañera con desviador, soporte de ducha integrado, soporte de ducha orientable, flexible Gliss 1,5 m y ducha de mano.

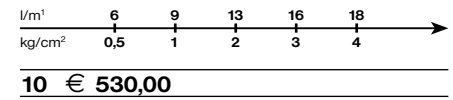

Miscelatore monocomando per vasca con deviatore, supporto doccia integrato, flessibile Gliss 1,5 m e doccia.

Wall mounted bath-shower mixer with diverter, built-in shower bracket, Gliss flexible tube 1,5 m and handshower.

Mitigeur monocommande de bain-douche avec support douche incorporé, flexible Gliss 1,5 m et douchette.

Bade-Einhebelmischer, Aufputz mit eingebautem Brausehalter, Gliss Brause-schlauch 1,5 m und Handbrause.

Mezclador monomando para bañera con desviador, soporte de ducha integrado, flexible Gliss 1,5 m y ducha de mano.

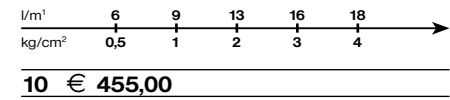

Miscelatore monocomando per vasca con deviatore, supporto doccia integrato, senza flessibile né doccia.

Wall mounted bath-shower mixer with diverter, built-in shower bracket, without shower kit.

Mitigeur monocommande de bain-douche avec support douche incorporé sans douchette ni flexible.

Bade-Einhebelmischer, Aufputz mit eingebautem Brausehalter ohne Handbrause und ohne Brauseschlauch.

Mezclador monomando para bañera con desviador, soporte de ducha integrado sin flexible ni ducha de mano.

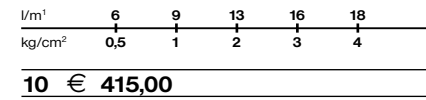

091012

091025

091015

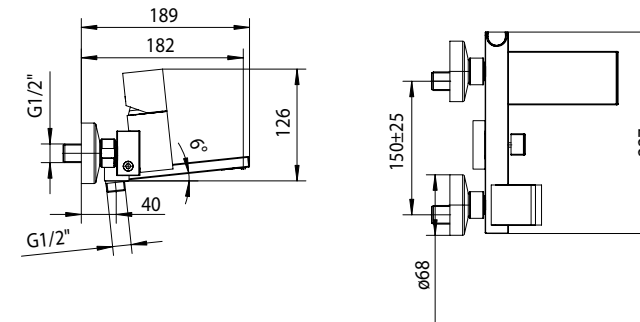
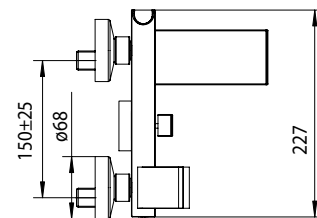
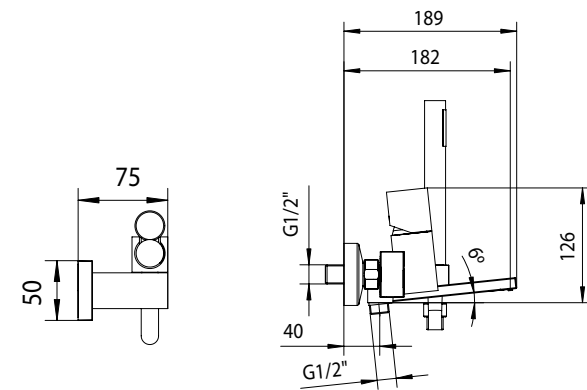

Miscelatore monocomando da incasso completo per vasca-doccia con deviatore automatico.

Complete concealed single lever mixer for bath shower with automatic diverter.

Mitigeur monocommande à encastrer complet pour bain-douche avec inverseur automatique.

Komplett Unterputz Wannenfäll und Brausebatterie mit Umsteller.

Mezclador monomando empotrable para baño-ducha completo con desviador automático.

UNICO®, corpo da incasso per miscelatore monocomando vasca-doccia con deviatore automatico, senza parti esterne.

UNICO®, concealed body for bath-shower with automatic diverter, without exposed parts.

UNICO®, corps de mitigeur monocommande à encastrer de bain-douche avec inverseur, sans parties extérieures.

UNICO®, Unterputz Körper für Wannenfäll und Brausebatterie mit Umsteller, ohne Aufputzteile.

UNICO®, cuerpo de mezclador monomando empotrable para baño-ducha con desviador automático, sin partes externas.

Solo parti esterne per miscelatore monocomando vasca-doccia con deviatore.

Exposed parts only for bath-shower concealed mixer with automatic diverter.

Parties extérieures seules pour mitigeur monocommande de bain-douche avec inverseur automatique.

Aufputzteile für Wannenfäll und Brausebatterie mit Umsteller.

Partes externas de mezclador monomando empotrable para baño-ducha con desviador automático.

Miscelatore monocomando da incasso completo per doccia.

Complete concealed single lever mixer for shower.

Mitigeur monocommande complet à encastrer pour douche.

Komplett Unterputz Brausebatterie.

Mezclador monomando empotrable completo para ducha.

UNICO®, corpo da incasso per miscelatore monocomando per doccia, senza parti esterne.

UNICO®, concealed body for shower, without exposed parts.

UNICO®, corps de mitigeur monocommande à encastrer pour douche, sans parties extérieures.

UNICO®, Unterputzkörper für Brausebatterie ohne Aufputzteile.

UNICO®, cuerpo de mezclador monomando empotrable para ducha, sin partes externas.

Solo parti esterne per miscelatore monocomando da incasso per doccia.

Exposed parts only for shower concealed mixer.

Parties extérieures seule pour mitigeur monocommande à encastrer pour douche.

Aufputzteile Teile für Unterputzbrausebatterie.

Sólo partes externas para mezclador monomando empotrable para ducha.

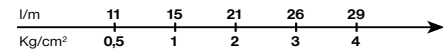

10 € 255,00

091020

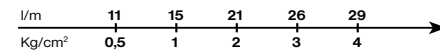

10 € 99,00

992727



[unico]

10 € 160,00

091021

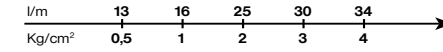

10 € 165,00

092010

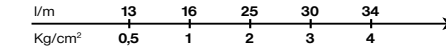
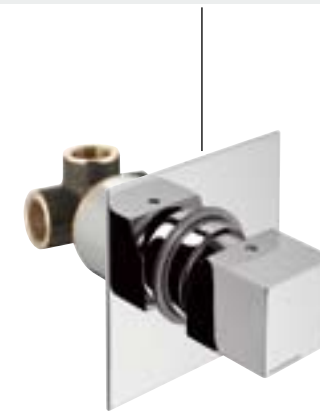

10 € 39,50

992726



[unico]

10 € 128,50

092011



Miscelatore monocomando da incasso completo per doccia in POLIPROPILENE.

Mitigeur monocommande à encastrer pour douche complet en POLIPROPILENE.

Unterputz Einhebelmischer komplett für Dusche aus POLIPROPILENE.

Mezclador monomando empotrable completo para ducha de POLIPROPILENE.

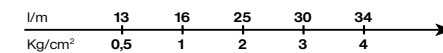

10 € 165,00

092910

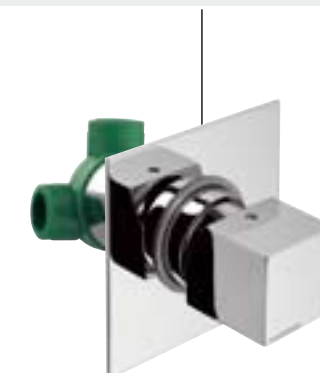

UNICO®, POLIPROPILENE

10 € 39,50

992732



[unico]

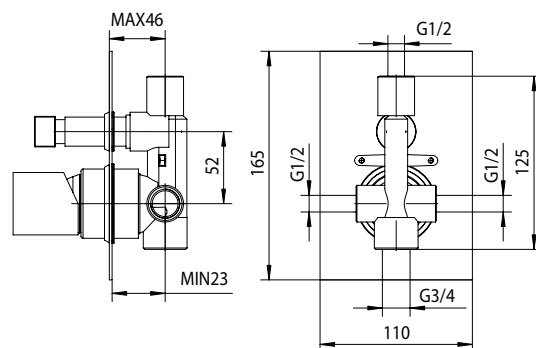
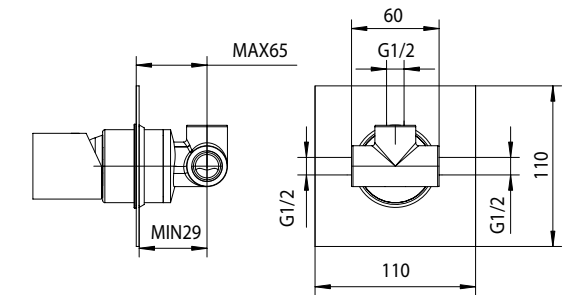

Miscelatore monocomando da incasso multi-funzione con deviatore a dischi in ceramica, **2 uscite**.
 Concealed single control mixer, multi-function with ceramic disc 2 outlets diverter.
 Mitigeur monocommande à encaster, multi-fonction avec inverseur à disques en céramique, 2 sorties.
 Unterputz Einhebelmischer Multifunktion mit Keramik 2-Wegeumsteller.
 Mezclador monomando para empotrar con desviador con discos de cerámica a 2 salidas.

l/m ³	13	16	25	30	34
kg/cm ²	0,5	1	2	3	4
10 €	310,00				

092062

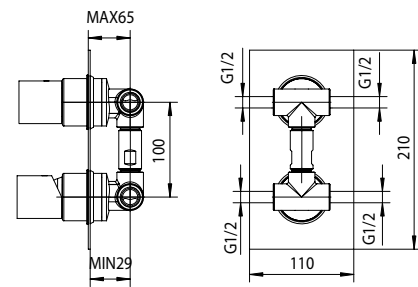

Miscelatore monocomando da incasso multi-funzione con deviatore a dischi in ceramica, **3 uscite**.
 Concealed single control mixer, multi-function with ceramic disc 3 outlets diverter.
 Mitigeur monocommande à encaster, multi-fonction avec inverseur à disques en céramique, 3 sorties.
 Unterputz Einhebelmischer Multifunktion mit Keramik 3-Wegeumsteller.
 Mezclador monomando para empotrar con desviador discos de cerámica a 3 salidas.

l/m ³	13	16	25	30	34
kg/cm ²	0,5	1	2	3	4
10 €	349,00				

092063

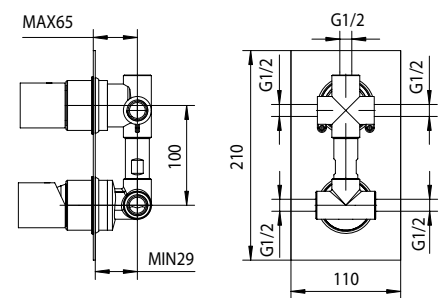

Miscelatore monocomando da incasso multi-funzione con deviatore a dischi in ceramica, **4 uscite**.
 Concealed single control mixer, multi-function with ceramic disc 4 outlets diverter.
 Mitigeur monocommande à encaster, multi-fonction avec inverseur à disques en céramique, 4 sorties.
 Unterputz Einhebelmischer Multifunktion mit Keramik 4-Wegeumsteller.
 Mezclador monomando para empotrar con desviador discos de cerámica a 4 salidas.

l/m ³	13	16	25	30	34
kg/cm ²	0,5	1	2	3	4
10 €	362,00				

092064

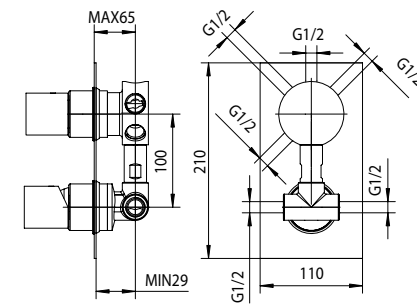
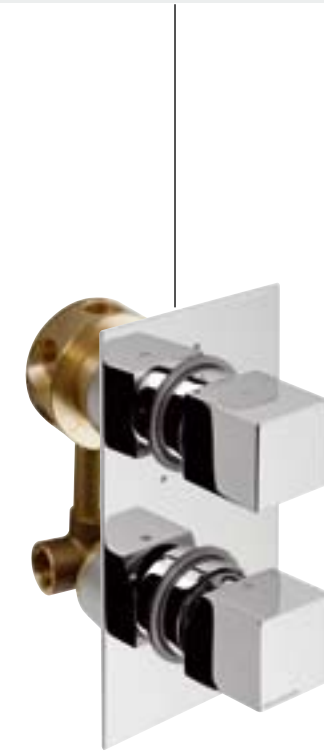

Miscelatore monocomando da incasso multi-funzione con deviatore a dischi in ceramica, **5 uscite**.
 Concealed single control mixer, multi-function with ceramic disc 5 outlets diverter.
 Mitigeur monocommande à encaster, multi-fonction avec inverseur à disques en céramique, 5 sorties.
 Unterputz Einhebelmischer Multifunktion mit Keramik 5-Wegeumsteller.
 Mezclador monomando para empotrar con desviador discos de cerámica a 5 salidas.

l/m ³	13	16	25	30	34
kg/cm ²	0,5	1	2	3	4
10 €	362,00				

092065

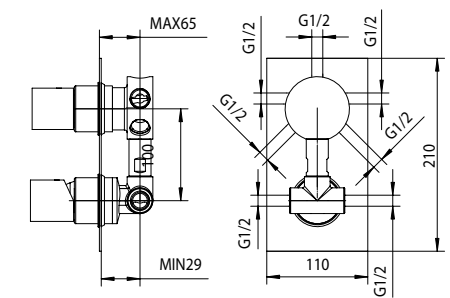
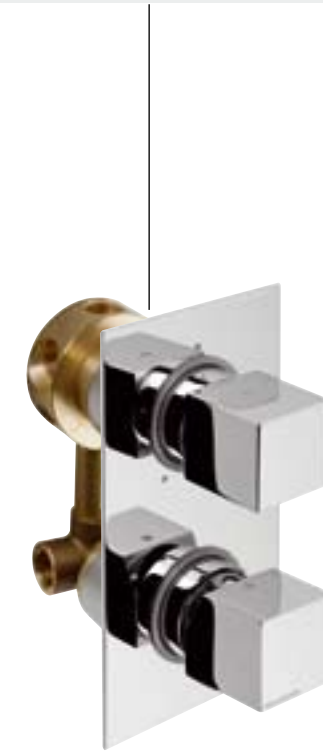

UNICO®, corpo per miscelatore monocomando da incasso multi-funzione con deviatore a dischi in ceramica, **2 uscite.**

UNICO®, body for concealed single control mixer, multi-function with ceramic disc diverter, 2 outlets.

UNICO®, corps pour mitigeur monocommande à encastrer, multi-fonction avec inverseur à disques en céramique, 2 sorties.

UNICO®, Körper für Unterputz Einhebelmischer Multifunktion mit Keramik 2-Wegeumsteller.

UNICO®, cuerpo de mezclador monomando para empotrar con desviador discos de cerámica a 2 salidas.

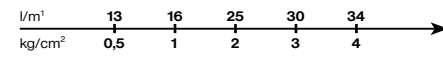

10 € 126,00

UNICO®, corpo per miscelatore monocomando da incasso multi-funzione con deviatore a dischi in ceramica, **3 uscite.**

UNICO®, body for concealed single control mixer, multi-function with ceramic disc diverter, 3 outlets.

UNICO®, corps pour mitigeur monocommande à encastrer, multi-fonction avec inverseur à disques en céramique, 3 sorties.

UNICO®, Körper für Unterputz Einhebelmischer Multifunktion mit Keramik 3-Wegeumsteller.

UNICO®, cuerpo de mezclador monomando para empotrar con desviador discos de cerámica a 3 salidas.

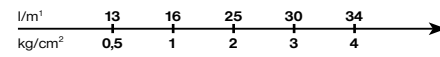

10 € 165,00

992739

[unico]



Solo parti esterne - Exposed parts only
Parties extérieures seule - Aufputzteile
Partes externas

10 € 189,00

992740

[unico]



Solo parti esterne - Exposed parts only
Parties extérieures seule - Aufputzteile
Partes externas

10 € 189,00

UNICO®, corpo per miscelatore monocomando da incasso multi-funzione con deviatore a dischi in ceramica, **4 uscite.**

UNICO®, body for concealed single control mixer, multi-function with ceramic disc diverter, 4 outlets.

UNICO®, corps pour mitigeur monocommande à encastrer, multi-fonction avec inverseur à disques en céramique, 4 sorties.

UNICO®, Körper für Unterputz Einhebelmischer Multifunktion mit Keramik 4-Wegeumsteller.

UNICO®, cuerpo de mezclador monomando para empotrar con desviador discos de cerámica a 4 salidas.

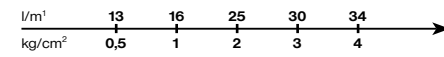

10 € 178,00

UNICO®, corpo per miscelatore monocomando da incasso multi-funzione con deviatore a dischi in ceramica, **5 uscite.**

UNICO®, body for concealed single control mixer, multi-function with ceramic disc diverter, 5 outlets.

UNICO®, corps pour mitigeur monocommande à encastrer, multi-fonction avec inverseur à disques en céramique, 5 sorties.

UNICO®, Körper für Unterputz Einhebelmischer Multifunktion mit Keramik 5-Wegeumsteller.

UNICO®, cuerpo de mezclador monomando para empotrar con desviador discos de cerámica a 5 salidas.

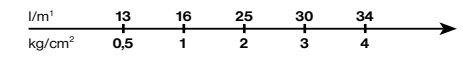

10 € 178,00

992744

[unico]



Solo parti esterne - Exposed parts only
Parties extérieures seule - Aufputzteile
Partes externas

10 € 189,00

992745

[unico]



Solo parti esterne - Exposed parts only
Parties extérieures seule - Aufputzteile
Partes externas

10 € 189,00

092132



092133



092134



092135



track

Miscelatore termostatico da incasso da **1/2"** con **rubinetto da 1/2"** a dischi in ceramica a 180°.

Concealed 1/2" thermostatic mixer with built-in 1/2" ceramic disc tap, 180°.

Mitigeur thermostatique 1/2" à encastrer, avec robinet 1/2" à disques en céramique, 180°.

Unterputz 1/2" Thermostat-Mischer mit 1/2" Keramische Scheiben Absperrventil 180°.

Mezclador termostático 1/2" empotrable, con grifo 1/2" con discos de cerámica 180°.

Miscelatore termostatico da incasso da **3/4"** con **rubinetto da 3/4"** a dischi in ceramica a 180°.

Concealed 3/4" thermostatic mixer with built-in 3/4" ceramic disc tap, 180°.

Mitigeur thermostatique 3/4" à encastrer, avec robinet 3/4" à disques en céramique, 180°.

Unterputz 3/4" Thermostat-Mischer mit 3/4" Keramische Scheiben Absperrventil 180°.

Mezclador termostático 3/4" empotrable, con grifo 3/4" con discos de cerámica 180°.

Miscelatore termostatico **1/2"** da incasso con deviatore a dischi in ceramica a **2 uscite** e funzione di stop.

1/2" thermostatic mixer, concealed installation with 2 outlets diverter, ceramic discs and stop function.

Mitigeur thermostatique à encastrer 1/2" avec inverseur à disques en céramique, 2 sorties et avec fonction de stop.

Unterputz 1/2" Thermostat-Mischer mit Keramik 2-Wegeumsteller mit Stop-Position.

Mezclador termostático 1/2" empotrable, desviador con discos de cerámica a 2 salidas con stop.

Miscelatore termostatico **3/4"** da incasso con deviatore a dischi in ceramica a **2 uscite** e funzione di stop.

3/4" thermostatic mixer, concealed installation with 2 outlets diverter, ceramic discs and stop function.

Mitigeur thermostatique à encastrer 3/4" avec inverseur à disques en céramique, 2 sorties et avec fonction de stop.

Unterputz 3/4" Thermostat-Mischer mit Keramik 2-Wegeumsteller mit Stop-Position.

Mezclador termostático 3/4" empotrable, desviador con discos de cerámica a 2 salidas con stop.

Miscelatore termostatico **1/2"** da incasso con deviatore a dischi in ceramica a **3 uscite** e funzione di stop.

1/2" thermostatic mixer, concealed installation with 3 outlets diverter, ceramic discs and stop function.

Mitigeur thermostatique à encastrer 1/2" avec inverseur à disques en céramique, 3 sorties et avec fonction de stop.

Unterputz 1/2" Thermostat-Mischer mit Keramik 3-Wegeumsteller mit Stop-Position.

Mezclador termostático 1/2" empotrable, desviador con discos de cerámica a 3 salidas con stop.

Miscelatore termostatico **3/4"** da incasso con deviatore a dischi in ceramica a **3 uscite** e funzione di stop.

3/4" thermostatic mixer, concealed installation with 3 outlets diverter, ceramic discs and stop function.

Mitigeur thermostatique à encastrer 3/4" avec inverseur à disques en céramique, 3 sorties et avec fonction de stop.

Unterputz 3/4" Thermostat-Mischer mit Keramik 3-Wegeumsteller mit Stop-Position.

Mezclador termostático 3/4" empotrable, desviador con discos de cerámica a 3 salidas con stop.

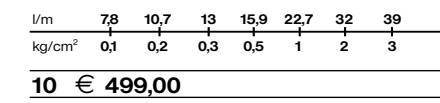
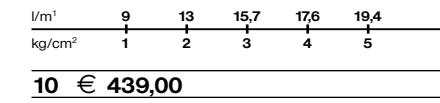
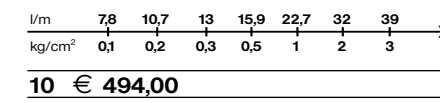
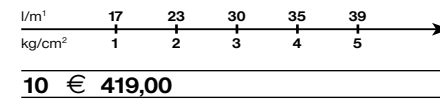
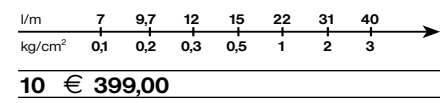
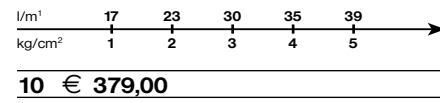

412410

412414

412425

412427

412426

412428

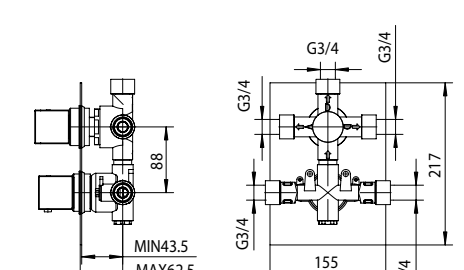
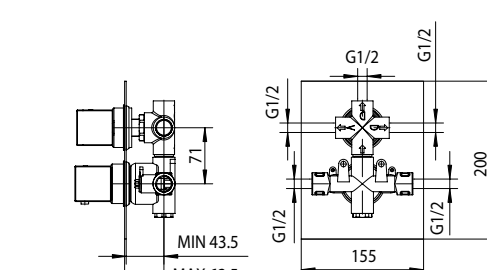
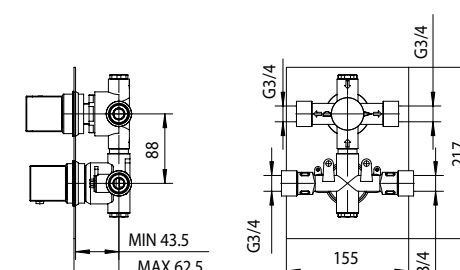
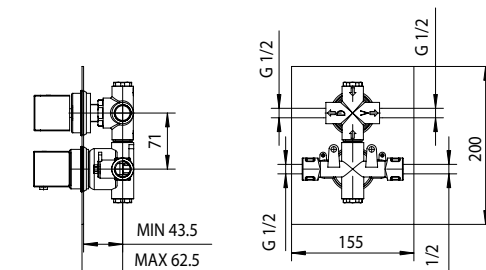
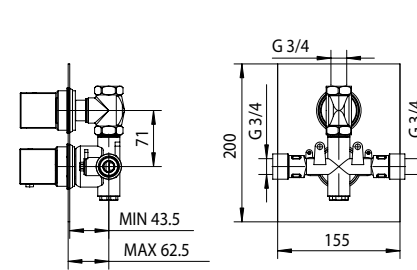
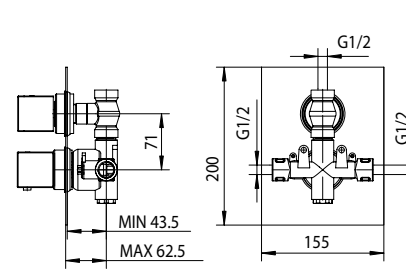
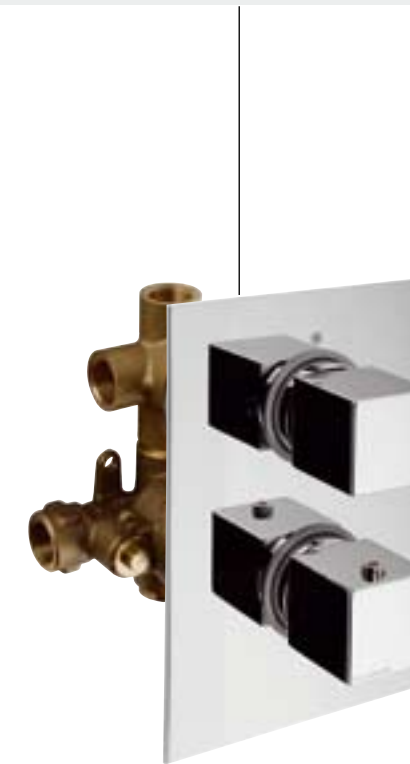

UNICO®, corpo per miscelatore termostatico da 1/2" con rubinetto da 1/2" a dischi in ceramica a 180°.

UNICO®, body for 1/2" thermostatic mixer, concealed installation, with built-in 1/2" ceramic disc tap, 180°.

UNICO®, corps pour mitigeur thermostatique 1/2" à encaster, avec robinet 1/2" à disques en céramique, 180°.

UNICO®, Körper für Unterputz 1/2" Thermostat-Mischer mit 1/2" Keramische Scheiben Absperrventil 180°.

UNICO®, cuerpo de mezclador termostático 1/2" empotrable, con grifo 1/2" con discos de cerámica 180°.

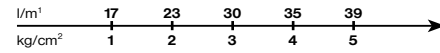

10 € 165,00

992771

[unico]



Solo parti esterne - Exposed parts only
Parties extérieures seule - Aufputzteile
Partes externas

10 € 219,00

UNICO®, corpo per miscelatore termostatico da 3/4" con rubinetto da 3/4" a dischi in ceramica a 180°.

UNICO®, body for 3/4" thermostatic mixer, concealed installation, with built-in 3/4" ceramic disc tap, 180°.

UNICO®, corps pour mitigeur thermostatique 3/4" à encaster, avec robinet 3/4" à disques en céramique, 180°.

UNICO®, Körper für Unterputz 3/4" Thermostat-Mischer mit 3/4" Keramische Scheiben Absperrventil 180°.

UNICO®, cuerpo de mezclador termostático 3/4" empotrable, con grifo 3/4" con discos de cerámica 180°.

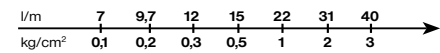

10 € 185,00

992772

[unico]



Solo parti esterne - Exposed parts only
Parties extérieures seule - Aufputzteile
Partes externas

10 € 219,00

UNICO®, corpo per miscelatore termostatico 1/2" da incasso con deviatore a dischi in ceramica a 2 uscite e funzione di stop.

UNICO®, body for 1/2" thermostatic mixer, concealed installation, with 2 outlets diverter, ceramic discs and stop function.

UNICO®, corps pour mitigeur thermostatique 1/2" inverseur à disques en céramique, 2 sorties et avec fonction de stop.

UNICO®, Körper für Unterputz 1/2" Thermostat-Mischer mit Keramik 2-Wegeumsteller mit Stop-Position.

UNICO®, cuerpo de mezclador termostático 1/2" empotrable con desviador con discos de cerámica a 2 salidas con stop.

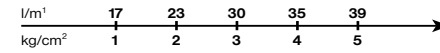

10 € 205,00

992773

[unico]



Solo parti esterne - Exposed parts only
Parties extérieures seule - Aufputzteile
Partes externas

10 € 219,00

UNICO®, corpo per miscelatore termostatico 3/4" da incasso con deviatore a dischi in ceramica a 2 uscite e funzione di stop.

UNICO®, body for 3/4" thermostatic mixer, concealed installation, with 2 outlets diverter, ceramic discs and stop function.

UNICO®, corps pour mitigeur thermostatique 3/4" à encaster 3/4" avec inverseur à disques en céramique, 2 sorties et avec fonction de stop.

UNICO®, Körper für Unterputz 3/4" Thermostat-Mischer mit Keramik 2-Wegeumsteller mit Stop-Position.

UNICO®, cuerpo de mezclador termostático 3/4" empotrable con desviador con discos de cerámica a 2 salidas con stop.

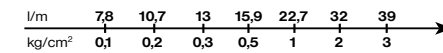

10 € 280,00

992774

[unico]



Solo parti esterne - Exposed parts only
Parties extérieures seule - Aufputzteile
Partes externas

10 € 219,00

UNICO®, corpo per miscelatore termostatico 1/2" da incasso con deviatore a dischi in ceramica a 3 uscite e funzione di stop.

UNICO®, body for 1/2" thermostatic mixer, concealed installation, with 3 outlets diverter, ceramic discs and stop function.

UNICO®, corps pour mitigeur thermostatique 1/2" à encaster 1/2" avec inverseur à disques en céramique, 3 sorties et avec fonction de stop.

UNICO®, Körper für Unterputz 1/2" Thermostat-Mischer mit Keramik 3-Wegeumsteller mit Stop-Position.

UNICO®, cuerpo de mezclador termostático 1/2" empotrable con desviador con discos de cerámica a 3 salidas con stop.

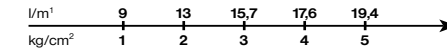

10 € 225,00

992775

[unico]



Solo parti esterne - Exposed parts only
Parties extérieures seule - Aufputzteile
Partes externas

10 € 219,00

UNICO®, corpo per miscelatore termostatico 3/4" da incasso con deviatore a dischi in ceramica a 3 uscite e funzione di stop.

UNICO®, body for 3/4" thermostatic mixer, concealed installation, with 3 outlets diverter, ceramic discs and stop function.

UNICO®, corps pour mitigeur thermostatique 3/4" à encaster 3/4" avec inverseur à disques en céramique, 3 sorties et avec fonction de stop.

UNICO®, Körper für Unterputz 3/4" Thermostat-Mischer mit Keramik 3-Wegeumsteller mit Stop-Position.

UNICO®, cuerpo de mezclador termostático 3/4" empotrable con desviador con discos de cerámica a 3 salidas con stop.

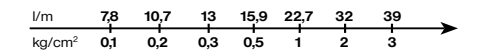

10 € 285,00

992776

[unico]



Solo parti esterne - Exposed parts only
Parties extérieures seule - Aufputzteile
Partes externas

10 € 219,00

412500



412501



412502



412503



412504



412505



click



click



finiture disponibili
available finishes
finition disponibles
verfügbare Farben
acabados disponibles

10 Cromo - Chrome
Chromé - Chrom





click click

click



Miscelatore monocomando per lavabo con scarico da 1" 1/4.
 Single control mixer for washbasin, with pop-up waste 1" 1/4.
 Mitigeur monocommande de lavabo, avec vidage 1" 1/4.
 Waschtisch Einhebelmischer mit Ablaufgarnitur 1" 1/4.
 Mezclador monomando para lavabo, con desagüe 1" 1/4.

Miscelatore monocomando per lavabo senza scarico.
 Single control mixer for washbasin, without waste.
 Mitigeur monocommande de lavabo, sans vidage.
 Waschtisch Einhebelmischer ohne Ablaufgarnitur.
 Mezclador monomando para lavabo, sin desagüe.

Miscelatore monocomando per lavabo con scarico da 1" 1/4, bocca prolungata 175 mm.
 Single control mixer for washbasin, with pop-up waste 1" 1/4, extended spout 175 mm.
 Mitigeur monocommande de lavabo, avec vidage 1" 1/4, bec 175 mm.
 Waschtisch Einhebelmischer mit Ablaufgarnitur 1" 1/4, Auslauf 175 mm.
 Mezclador monomando para lavabo, con desagüe 1" 1/4, caño prolongado mm 175.

Miscelatore monocomando per lavabo senza scarico, con bocca prolungata 175 mm.
 Single control mixer for washbasin, without waste, extended spout 175 mm.
 Mitigeur monocommande de lavabo, sans vidage, bec 175 mm.
 Waschtisch Einhebelmischer ohne Ablaufgarnitur, Auslauf 175 mm.
 Mezclador monomando para lavabo, sin desagüe, caño prolongado mm 175.

l/m	5	7	10	12	14
Kg/cm ²	0,5	1	2	3	4
10	€ 189,00				

l/m	5	7	10	12	14
Kg/cm ²	0,5	1	2	3	4
10	€ 175,50				

l/m	5	7	10	12	14
Kg/cm ²	0,5	1	2	3	4
10	€ 244,00				

l/m	5	7	10	12	14
Kg/cm ²	0,5	1	2	3	4
10	€ 230,50				

373010



373011



373038



373045

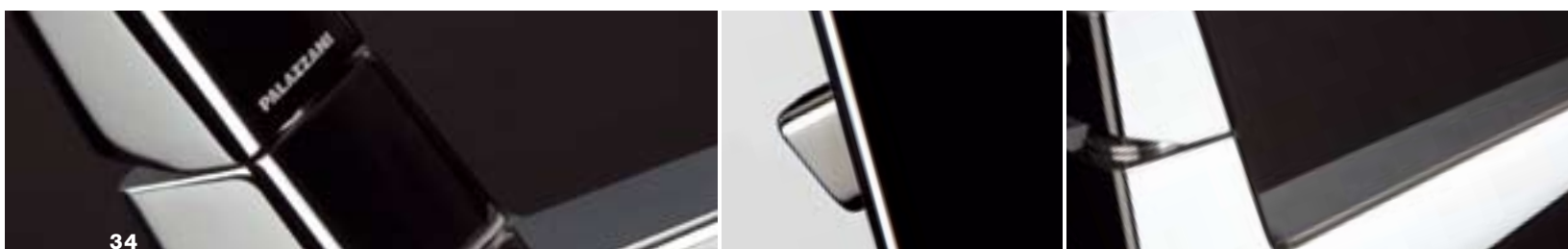
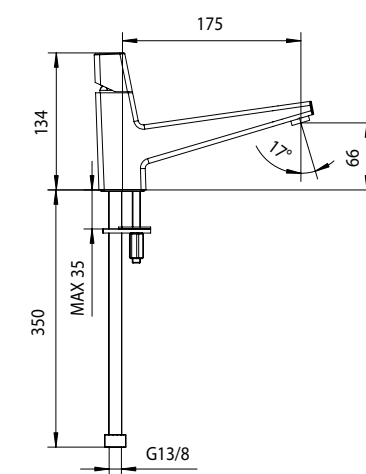
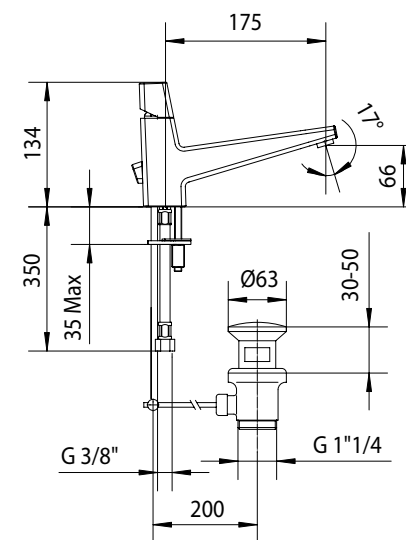
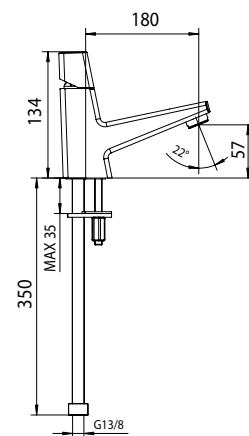
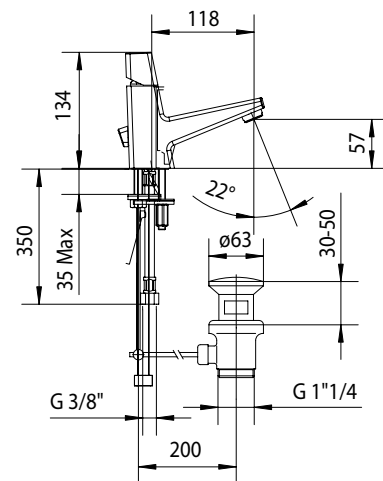

clickclick

click

Miscelatore monocomando alto per lavabo con scarico 1" 1/4 Click-Clack.
 Tall single control mixer for washbasin, Click-Clack waste 1" 1/4.
 Mitigeur monocommande haut de lavabo, avec vidage Click-Clack 1" 1/4.
 Hoch Waschtisch Einhebelmischer mit Click-Clack Ablaufgarnitur 1" 1/4.
 Mezclador monomando alto para lavabo con desagüe Click-Clack 1" 1/4.

Miscelatore monocomando alto per lavabo senza scarico.
 Tall single control mixer for washbasin, without waste.
 Mitigeur monocommande haut de lavabo, sans vidage.
 Hoch Waschtisch Einhebelmischer ohne Ablaufgarnitur.
 Mezclador monomando alto para lavabo, sin desagüe.

l/m	5	7	10	12	14
Kg/cm ²	0,5	1	2	3	4
10 € 299,00					

l/m	5	7	10	12	14
Kg/cm ²	0,5	1	2	3	4
10 € 264,00					

Miscelatore monocomando da incasso, per lavabo.
 Single control mixer for washbasin, concealed installation.
 Mitigeur monocommande à encastrer mural pour lavabo.
 Einhebelmischer für Waschtisch Unterputz.
 Mezclador monomando empotrable para lavabo.

l/m	5	7	10	12	14
Kg/cm ²	0,5	1	2	3	4
10 € 229,00					

Miscelatore monocomando per bidet con scarico 1" 1/4.
 Single control mixer for bidet, with pop up waste 1" 1/4.
 Mitigeur monocommande de bidet, avec vidage 1" 1/4.
 Bidet Einhebelmischer mit Ablaufgarnitur 1" 1/4.
 Mezclador monomando para bidet con desagüe 1" 1/4.

l/m	5	7	10	12	14
Kg/cm ²	0,5	1	2	3	4
10 € 195,00					

Miscelatore monocomando per bidet senza scarico.
 Single control mixer for bidet, without waste.
 Mitigeur monocommande de bidet, sans vidage.
 Bidet Einhebelmischer ohne Ablaufgarnitur.
 Mezclador monomando para bidet sin desagüe.

l/m	5	7	10	12	14
Kg/cm ²	0,5	1	2	3	4
10 € 181,50					

373077

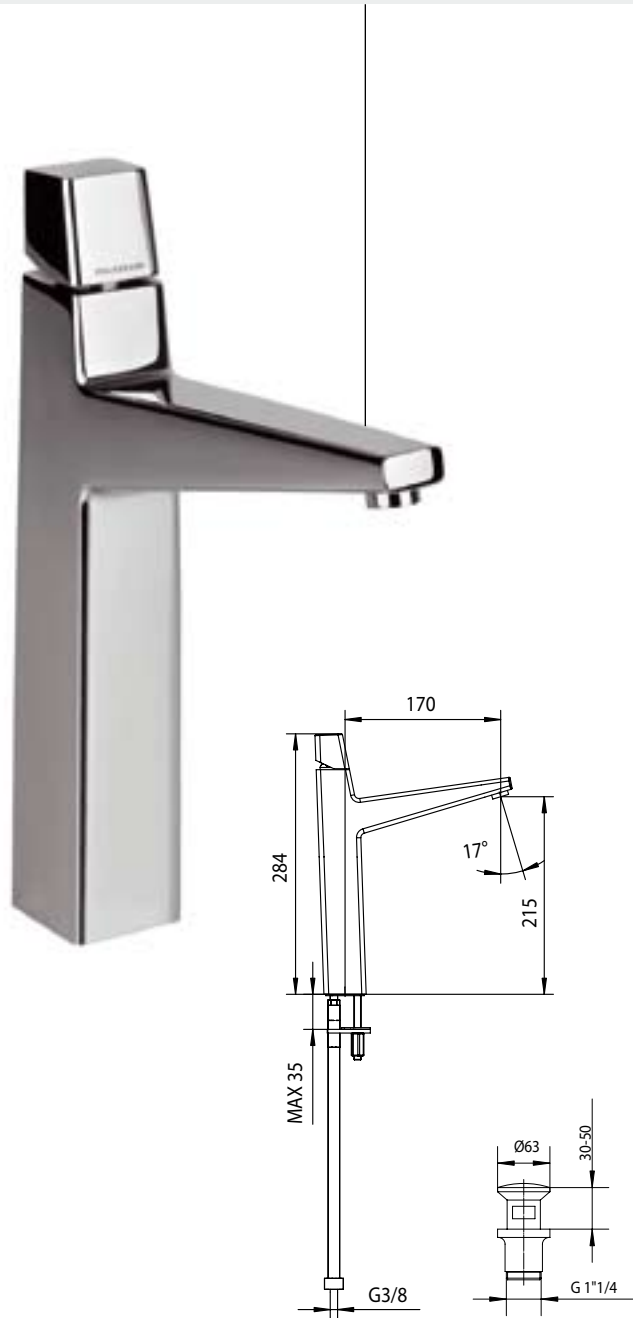

373018



373081

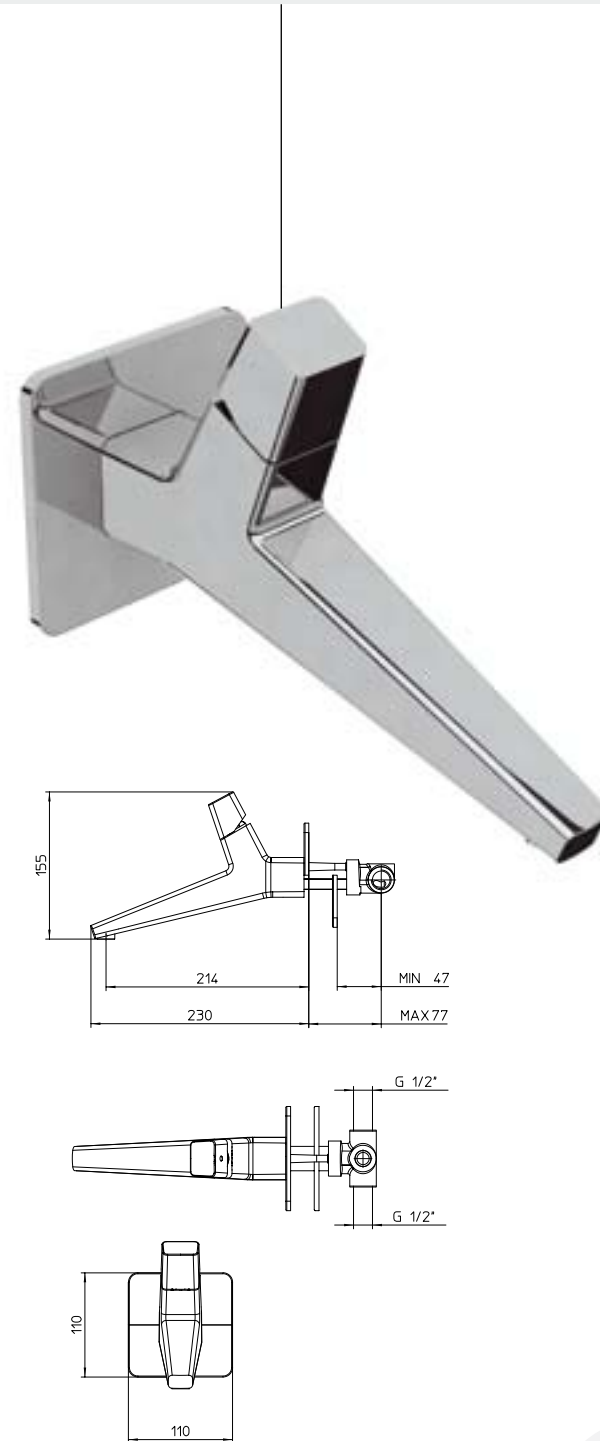

374010



374011



click

clickclick

Miscelatore monocomando *Full Contact* per vasca con deviatore, supporto doccia integrato, supporto doccia orientabile, flessibile Gliss 1,5 m e doccetta.

Wall mounted *Full Contact* bath-shower mixer with diverter, built-in shower bracket, wall mounted swivel bracket with Gliss flexible tube 1,5 m and handshower.

Mitigeur monocommande *Full Contact* de bain-douche avec support douche incorporé, flexible Gliss 1,5 m, douchette et support mural orientable.

Bade-Einhebelmischer *Full Contact*, Aufputz mit eingebautem Brausehalter mit Gliss Brauseschlauch 1,5 m, Handbrause und verstellbarer Brausehalter.

Mezclador monomando *Full Contact* para bañera con desviador, soporte de ducha integrado, soporte de ducha orientable, flexible Gliss 1,5 m y ducha de mano.

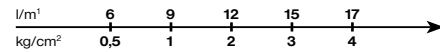

10 € 425,00

Miscelatore monocomando *Full Contact* per vasca con deviatore, supporto doccia integrato, flessibile Gliss 1,5 m e doccetta.

Wall mounted *Full Contact* bath-shower mixer with diverter, built-in shower bracket, Gliss flexible tube 1,5 m and handshower.

Mitigeur monocommande *Full Contact* de bain-douche avec support douche incorporé, flexible Gliss 1,5 m et douchette.

Bade-Einhebelmischer *Full Contact*, Aufputz mit eingebautem Brausehalter, Gliss Brauseschlauch 1,5 m und Handbrause.

Mezclador monomando *Full Contact* para bañera con desviador, soporte de ducha integrado, flexible Gliss 1,5 m y ducha de mano.

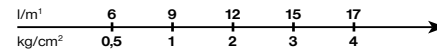

10 € 415,00

Miscelatore monocomando *Full Contact* per vasca con deviatore, supporto doccia integrato, supporto doccia orientabile, flessibile Gliss 1,5 m e doccetta.

Wall mounted *Full Contact* bath-shower mixer with diverter, built-in shower bracket, wall mounted swivel bracket with Gliss flexible tube 1,5 m and handshower.

Mitigeur monocommande *Full Contact* de bain-douche avec support douche incorporé, flexible Gliss 1,5 m, douchette et support mural orientable.

Bade-Einhebelmischer *Full Contact*, Aufputz mit eingebautem Brausehalter mit Gliss Brauseschlauch 1,5 m, Handbrause und verstellbarer Brausehalter.

Mezclador monomando *Full Contact* para bañera con desviador, soporte de ducha integrado, soporte de ducha orientable, flexible Gliss 1,5 m y ducha de mano.

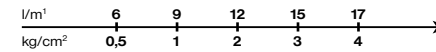

10 € 530,00

Miscelatore monocomando *Full Contact* per vasca, con deviatore, supporto doccia integrato, senza flessibile né doccetta.

Wall mounted *Full Contact* bath-shower mixer with diverter, built-in shower bracket without shower kit.

Mitigeur monocommande *Full Contact* de bain-douche avec support douche incorporé sans douchette ni flexible.

Bade-Einhebelmischer *Full Contact* mit eingebautem Brausehalter, ohne Handbrause und ohne Brauseschlauch.

Mezclador monomando *Full Contact* para bañera con desviador, soporte de ducha integrado sin flexible ni ducha de mano.

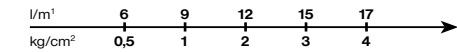

10 € 375,00

371012

371025

371096

371015

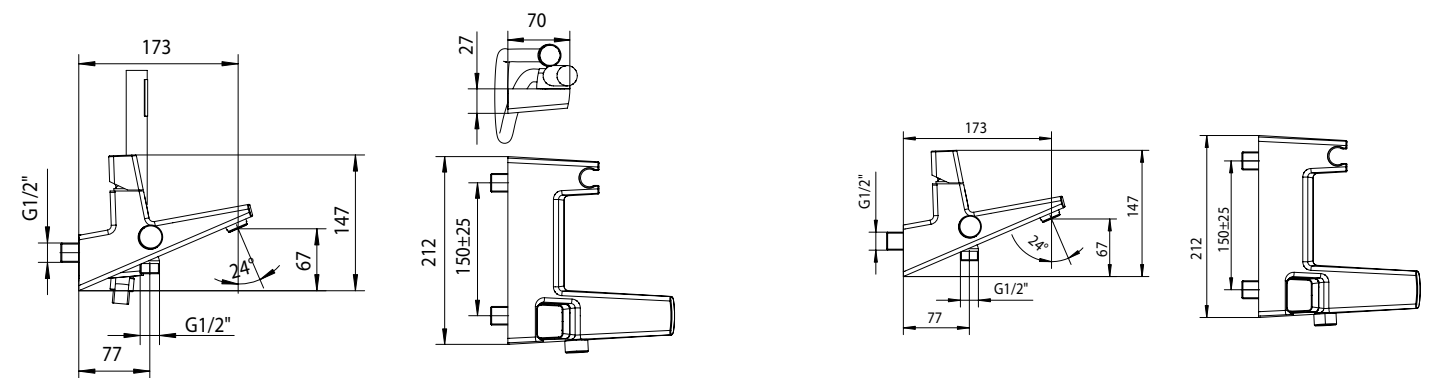
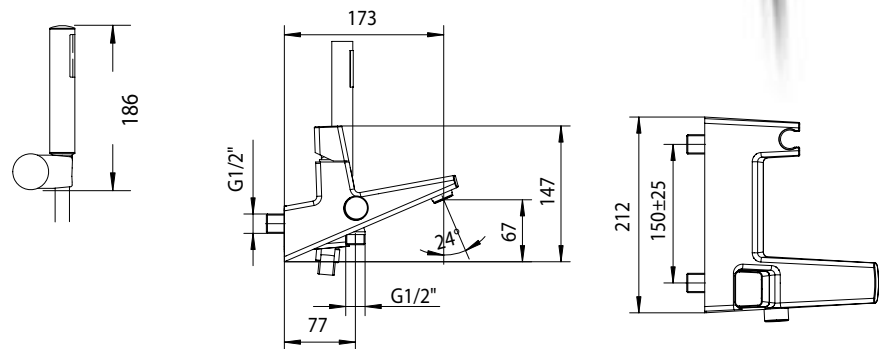

Miscelatore monocomando *Full Contact* per doccia, supporto doccia integrato, supporto doccia orientabile, flessibile Gliss 1,5 m e doccia.

Wall mounted *Full Contact* shower mixer, built-in shower bracket, wall mounted swivel bracket, Gliss flexible tube 1,5 m and handshower.

Mitigeur monocommande *Full Contact* de douche avec support douche incorporé, douchette, flexible Gliss 1,5 m et support mural orientable.

Brause-Einhebelmischer *Full Contact*, Aufputz mit eingebautem Brausehalter mit Gliss Brauseschlauch 1,5 m, Handbrause und verstellbarer Brausehalter.

Mezclador monomando *Full Contact* para ducha, soporte de ducha integrado, soporte de ducha orientable, flexible Gliss 1,5 m y ducha de mano.

l/m	6	9	12	15	17
Kg/cm ²	0,5	1	2	3	4
10 € 325,00					

Miscelatore monocomando *Full Contact* per doccia, supporto doccia integrato, con flessibile Gliss 1,5 m e doccia.

Wall mounted *Full Contact* shower mixer, built-in shower bracket, with Gliss flexible tube 1,5 m and handshower.

Mitigeur monocommande *Full Contact* de douche avec support douche incorporé, avec flexible Gliss 1,5 m et douchette.

Bade-Einhebelmischer *Full Contact*, Aufputz mit eingebautem Brausehalter, Gliss Brauseschlauch 1,5 m und Handbrause.

Mezclador monomando *Full Contact* para ducha, soporte de ducha integrado, flexible Gliss 1,5 m y ducha de mano.

l/m	6	9	12	15	17
Kg/cm ²	0,5	1	2	3	4
10 € 315,00					

Miscelatore monocomando *Full Contact* per doccia, supporto doccia integrato, senza flessibile né doccia.

Wall mounted *Full Contact* shower mixer, built-in shower bracket, without shower kit.

Mitigeur monocommande *Full Contact* de douche avec support douche incorporé, sans douchette ni flexible.

Brause-Einhebelmischer *Full Contact*, Aufputz mit eingebautem Brausehalter, ohne Handbrause und ohne Brauseschlauch.

Mezclador monomando *Full Contact* para ducha, soporte de ducha integrado, sin flexible ni ducha de mano.

l/m	6	9	12	15	17
Kg/cm ²	0,5	1	2	3	4
10 € 275,00					

Deviatore a due uscite da incasso.

Concealed two-outlets diverter.

Inverseur à encastrer à deux sorties.

Unterputz Zwei-Wegeumsteller.

Desviador empotrable de dos salidas.

l/m	13	18	25	30	34
Kg/cm ²	0,5	1	2	3	4
10 € 160,00					

Deviatore a tre uscite da incasso.

Concealed three-outlets diverter.

Inverseur à encastrer à trois sorties.

Unterputz Drei-Wegeumsteller.

Desviador empotrable de tres salidas.

l/m	13	18	25	30	34
Kg/cm ²	0,5	1	2	3	4
10 € 199,00					

click

372020

372027

372026

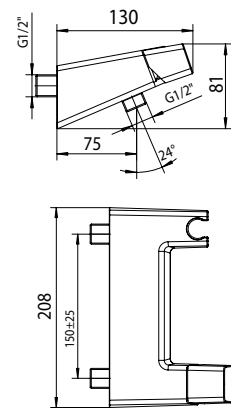
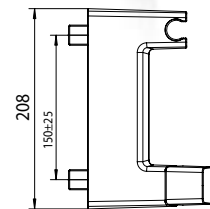
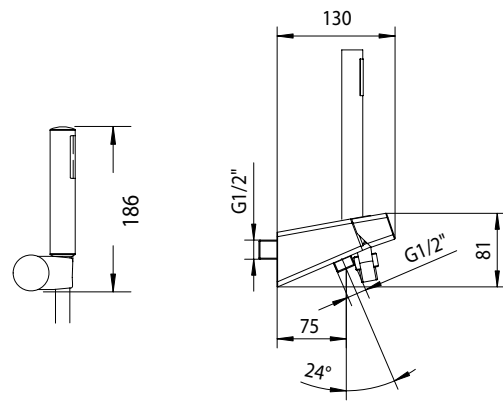

372030

372031



Deviatore a quattro uscite da incasso.

Concealed four-outlets diverter.

Inverseur à encastrer à quatre sorties.

Unterputz Vier-Wegeumsteller.

Desviador empotrable de cuatro salidas.

l/m	13	18	25	30	34
Kg/cm ²	0,5	1	2	3	4
10 € 212,00					

Deviatore a cinque uscite da incasso.

Concealed five-outlets diverter.

Inverseur à encastrer à cinq sorties.

Unterputz Fünf-Wegeumsteller.

Desviador empotrable de cinco salidas.

l/m	13	18	25	30	34
Kg/cm ²	0,5	1	2	3	4
10 € 212,00					

372038

372039



click

Miscelatore monocomando da incasso completo per vasca-doccia con deviatore automatico.

Complete concealed single lever mixer for bath shower with automatic diverter.

Mitigeur monocommande à encastrer complet pour bain-douche avec inverseur automatique.

Komplett Unterputz Wannenfäll und Brausebatterie mit Umsteller.

Mezclador monomando empotrable para baño-ducha completo con desviador automático.

UNICO®, corpo da incasso per miscelatore monocomando vasca-doccia con deviatore automatico, senza parti esterne.

UNICO®, concealed body for bath-shower with automatic diverter, without exposed parts.

UNICO®, corps de mitigeur monocommande à encastrer de bain-douche avec inverseur, sans parties extérieures.

UNICO®, Unterputz Körper für Wannenfäll und Brausebatterie mit Umsteller, ohne Aufputzteile.

UNICO®, cuerpo de mezclador monomando empotrable para baño-ducha con desviador automático, sin partes externas.

Solo parti esterne per miscelatore monocomando vasca-doccia con deviatore.

Exposed parts only for bath-shower concealed mixer with automatic diverter.

Parties extérieures seules pour mitigeur monocommande de bain-douche avec inverseur automatique.

Aufputzteile für Wannenfäll und Brausebatterie mit Umsteller.

Partes externas de mezclador monomando empotrable para baño-ducha con desviador automático.

Miscelatore monocomando da incasso completo per doccia.

Complete concealed single lever mixer for shower.

Mitigeur monocommande complet à encastrer pour douche.

Komplett Unterputz Brausebatterie.

Mezclador monomando empotrable completo para ducha.

UNICO®, corpo da incasso per miscelatore monocomando per doccia, senza parti esterne.

UNICO®, concealed body for shower, without exposed parts.

UNICO®, corps de mitigeur monocommande à encastrer pour douche, sans parties extérieures.

UNICO®, Unterputzkörper für Brausebatterie ohne Aufputzteile.

UNICO®, cuerpo de mezclador monomando empotrable para ducha, sin partes externas.

Solo parti esterne per miscelatore monocomando da incasso per doccia.

Exposed parts only for shower concealed mixer.

Parties extérieures seules pour mitigeur monocommande à encastrer pour douche.

Aufputzteile Teile für Unterputzbrausebatterie.

Sólo partes externas para mezclador monomando empotrable para ducha.

l/m	11	15	21	26	29
Kg/cm ²	0,5	1	2	3	4

10 € 245,00

l/m	11	15	21	26	29
Kg/cm ²	0,5	1	2	3	4

10 € 99,00

10 € 150,00

l/m	13	16	25	30	34
Kg/cm ²	0,5	1	2	3	4

10 € 160,00

l/m	13	16	25	30	34
Kg/cm ²	0,5	1	2	3	4

10 € 39,50

10 € 123,50

371020



992727



[unico]

371021



372010

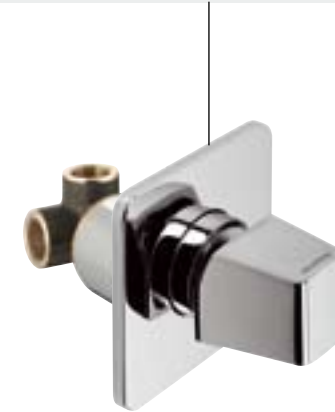

992726



[unico]

372011



Miscelatore monocomando da incasso completo per doccia in POLIPROPILENE.

POLIPROPYLENE concealed complete shower mixer.

Mitigeur monocommande à encastrer pour douche complet en POLIPROPILENE.

Unterputz Einhebelmischer komplett für Dusche aus POLIPROPILENE.

Mezclador monomando empotrable completo para ducha de POLIPROPILENE.

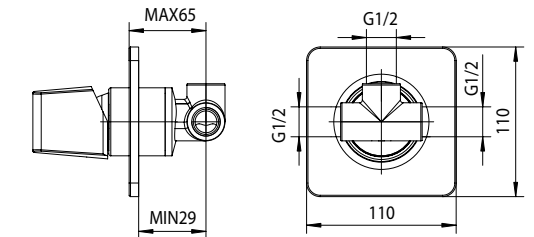

l/m	13	16	25	30	34
Kg/cm ²	0,5	1	2	3	4

10 € 160,00

UNICO®, POLIPROPILENE

10 € 39,50

372910



992732



[unico]

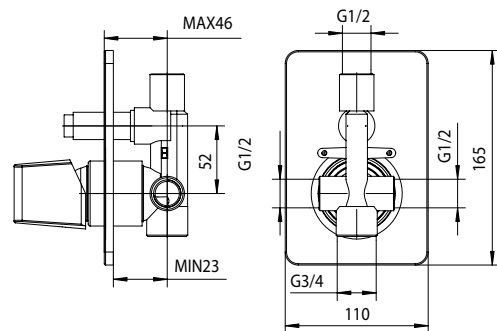

clickclick

Miscelatore monocomando da incasso multi-funzione con deviatore a dischi in ceramica, **2 uscite**.
 Concealed single control mixer, multi-function with ceramic disc 2 outlets diverter.
 Mitigeur monocommande à encastrer, multi-fonction avec inverseur à disques en céramique, 2 sorties.
 Unterputz Einhebelmischer Multifunktion mit Keramik 2-Wegeumsteller.
 Mezclador monomando para empotrar con desviador con discos de cerámica a 2 salidas.

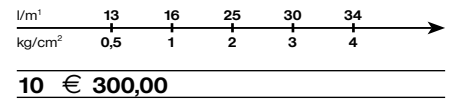

372062

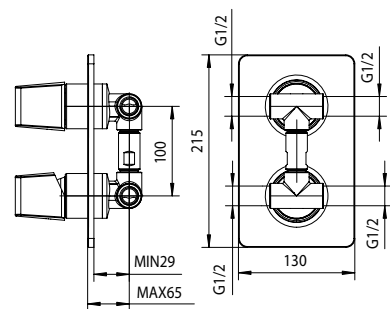

Miscelatore monocomando da incasso multi-funzione con deviatore a dischi in ceramica, **3 uscite**.
 Concealed single control mixer, multi-function with ceramic disc 3 outlets diverter.
 Mitigeur monocommande à encastrer, multi-fonction avec inverseur à disques en céramique, 3 sorties.
 Unterputz Einhebelmischer Multifunktion mit Keramik 3-Wegeumsteller.
 Mezclador monomando para empotrar con desviador discos de cerámica a 3 salidas.

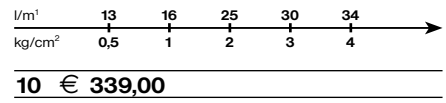

372063

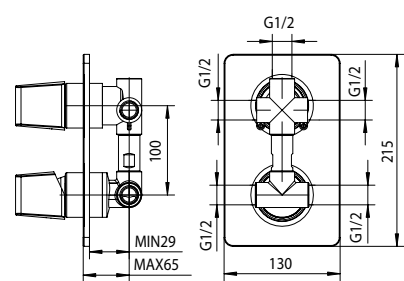
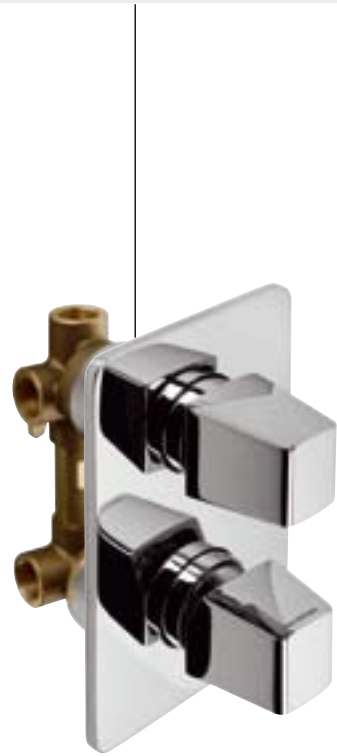

Miscelatore monocomando da incasso multi-funzione con deviatore a dischi in ceramica, **4 uscite**.
 Concealed single control mixer, multi-function with ceramic disc 4 outlets diverter.
 Mitigeur monocommande à encastrer, multi-fonction avec inverseur à disques en céramique, 4 sorties.
 Unterputz Einhebelmischer Multifunktion mit Keramik 4-Wegeumsteller.
 Mezclador monomando para empotrar con desviador discos de cerámica a 4 salidas.

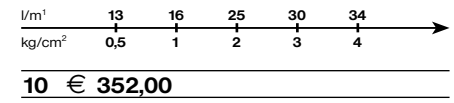

372064

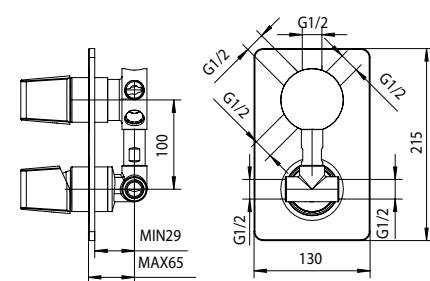

Miscelatore monocomando da incasso multi-funzione con deviatore a dischi in ceramica, **5 uscite**.
 Concealed single control mixer, multi-function with ceramic disc 5 outlets diverter.
 Mitigeur monocommande à encastrer, multi-fonction avec inverseur à disques en céramique, 5 sorties.
 Unterputz Einhebelmischer Multifunktion mit Keramik 5-Wegeumsteller.
 Mezclador monomando para empotrar con desviador discos de cerámica a 5 salidas.

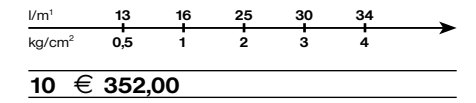

372065

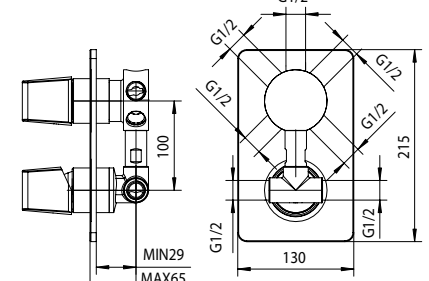

click

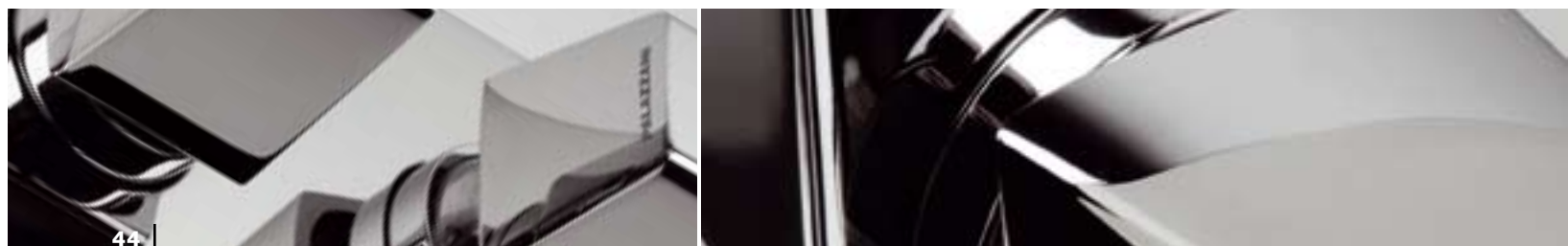

click

UNICO®, corpo per miscelatore monocomando da incasso multi-funzione con deviatore a dischi in ceramica, **2 uscite.**

UNICO®, body for concealed single control mixer, multi-function with ceramic disc diverter, 2 outlets.

UNICO®, corps pour mitigeur monocommande à encastrer, multi-fonction avec inverseur à disques en céramique, 2 sorties.

UNICO®, Körper für Unterputz Einhebelmischer Multifunktion mit Keramik 2-Wegeumsteller.

UNICO®, cuerpo de mezclador monomando para empotrar con desviador discos de cerámica a 2 salidas.

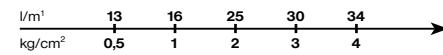

10 € 126,00

UNICO®, corpo per miscelatore monocomando da incasso multi-funzione con deviatore a dischi in ceramica, **3 uscite.**

UNICO®, body for concealed single control mixer, multi-function with ceramic disc diverter, 3 outlets.

UNICO®, corps pour mitigeur monocommande à encastrer, multi-fonction avec inverseur à disques en céramique, 3 sorties.

UNICO®, Körper für Unterputz Einhebelmischer Multifunktion mit Keramik 3-Wegeumsteller.

UNICO®, cuerpo de mezclador monomando para empotrar con desviador discos de cerámica a 3 salidas.

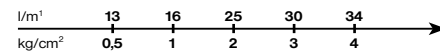

10 € 165,00

992739

[unico]



Solo parti esterne - Exposed parts only
Parties extérieures seule - Aufputzteile
Partes externas

10 € 179,00

992740

[unico]



Solo parti esterne - Exposed parts only
Parties extérieures seule - Aufputzteile
Partes externas

10 € 179,00

UNICO®, corpo per miscelatore monocomando da incasso multi-funzione con deviatore a dischi in ceramica, **4 uscite.**

UNICO®, body for concealed single control mixer, multi-function with ceramic disc diverter, 4 outlets.

UNICO®, corps pour mitigeur monocommande à encastrer, multi-fonction avec inverseur à disques en céramique, 4 sorties.

UNICO®, Körper für Unterputz Einhebelmischer Multifunktion mit Keramik 4-Wegeumsteller.

UNICO®, cuerpo de mezclador monomando para empotrar con desviador discos de cerámica a 4 salidas.

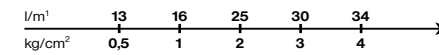

10 € 178,00

UNICO®, corpo per miscelatore monocomando da incasso multi-funzione con deviatore a dischi in ceramica, **5 uscite.**

UNICO®, body for concealed single control mixer, multi-function with ceramic disc diverter, 5 outlets.

UNICO®, corps pour mitigeur monocommande à encastrer, multi-fonction avec inverseur à disques en céramique, 5 sorties.

UNICO®, Körper für Unterputz Einhebelmischer Multifunktion mit Keramik 5-Wegeumsteller.

UNICO®, cuerpo de mezclador monomando para empotrar con desviador discos de cerámica a 5 salidas.

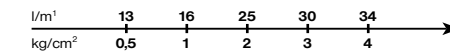

10 € 178,00

992744

[unico]



Solo parti esterne - Exposed parts only
Parties extérieures seule - Aufputzteile
Partes externas

10 € 179,00

992745

[unico]



Solo parti esterne - Exposed parts only
Parties extérieures seule - Aufputzteile
Partes externas

10 € 179,00

372132



372133



372134



372135

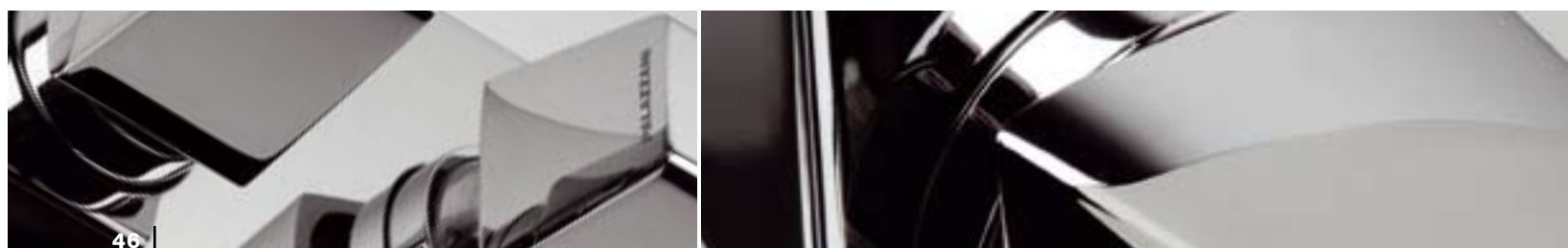

clickclick

Miscelatore termostatico da incasso da **1/2"** con **rubinetto da 1/2"** a dischi in ceramica a 180°.

Concealed 1/2" thermostatic mixer with built-in 1/2" ceramic disc tap, 180°.

Mitigeur thermostatique 1/2" à encastrer, avec robinet 1/2" à disques en céramique, 180°.

Unterputz 1/2" Thermostat-Mischer mit 1/2" Keramische Scheiben Absperrventil 180°.

Mezclador termostático 1/2" empotrable, con grifo 1/2" con discos de cerámica 180°.

Miscelatore termostatico da incasso da **3/4"** con **rubinetto da 3/4"** a dischi in ceramica a 180°.

Concealed 3/4" thermostatic mixer with built-in 3/4" ceramic disc tap, 180°.

Mitigeur thermostatique 3/4" à encastrer, avec robinet 3/4" à disques en céramique, 180°.

Unterputz 3/4" Thermostat-Mischer mit 3/4" Keramische Scheiben Absperrventil 180°.

Mezclador termostático 3/4" empotrable, con grifo 3/4" con discos de cerámica 180°.

Miscelatore termostatico **1/2"** da incasso con deviatore a dischi in ceramica a **2 uscite** e funzione di stop.

1/2" thermostatic mixer, concealed installation with 2 outlets diverter, ceramic discs and stop function.

Mitigeur thermostatique à encastrer 1/2" avec inverseur à disques en céramique, 2 sorties et avec fonction de stop.

Unterputz 1/2" Thermostat-Mischer mit Keramik 2-Wegeumsteller mit Stop-Position.

Mezclador termostático 1/2" empotrable, desviador con discos de cerámica a 2 salidas con stop.

Miscelatore termostatico **3/4"** da incasso con deviatore a dischi in ceramica a **2 uscite** e funzione di stop.

3/4" thermostatic mixer, concealed installation with 2 outlets diverter, ceramic discs and stop function.

Mitigeur thermostatique à encastrer 3/4" avec inverseur à disques en céramique, 2 sorties et avec fonction de stop.

Unterputz 3/4" Thermostat-Mischer mit Keramik 2-Wegeumsteller mit Stop-Position.

Mezclador termostático 3/4" empotrable, desviador con discos de cerámica a 2 salidas con stop.

Miscelatore termostatico **1/2"** da incasso con deviatore a dischi in ceramica a **3 uscite** e funzione di stop.

1/2" thermostatic mixer, concealed installation with 3 outlets diverter, ceramic discs and stop function.

Mitigeur thermostatique à encastrer 1/2" avec inverseur à disques en céramique, 3 sorties et avec fonction de stop.

Unterputz 1/2" Thermostat-Mischer mit Keramik 3-Wegeumsteller mit Stop-Position.

Mezclador termostático 1/2" empotrable, desviador con discos de cerámica a 3 salidas con stop.

Miscelatore termostatico **3/4"** da incasso con deviatore a dischi in ceramica a **3 uscite** e funzione di stop.

3/4" thermostatic mixer, concealed installation with 3 outlets diverter, ceramic discs and stop function.

Mitigeur thermostatique à encastrer 3/4" avec inverseur à disques en céramique, 3 sorties et avec fonction de stop.

Unterputz 3/4" Thermostat-Mischer mit Keramik 3-Wegeumsteller mit Stop-Position.

Mezclador termostático 3/4" empotrable, desviador con discos de cerámica a 3 salidas con stop.

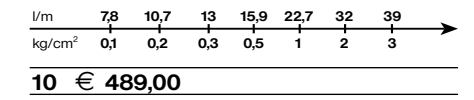
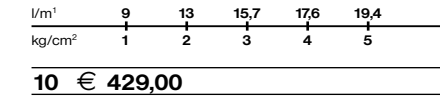
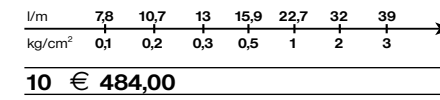
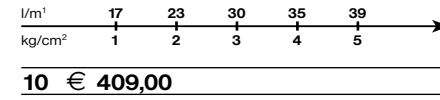
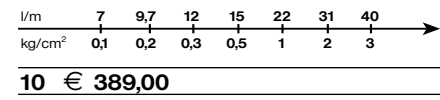
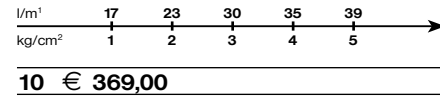

212410

212414

212425

212427

212426

212428

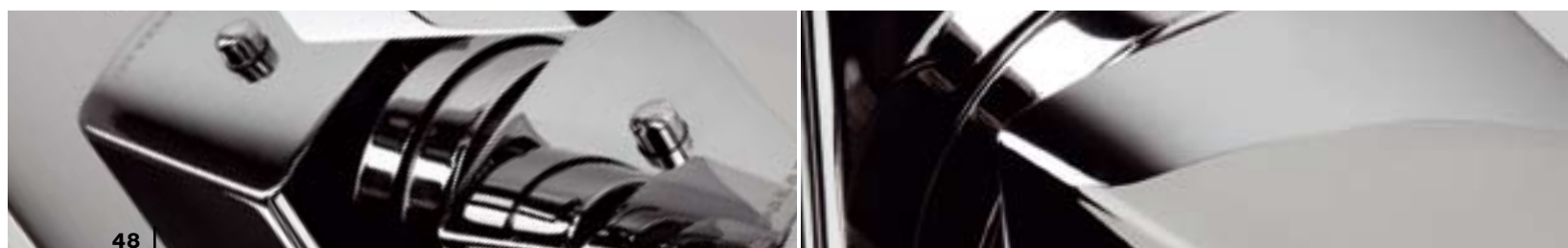
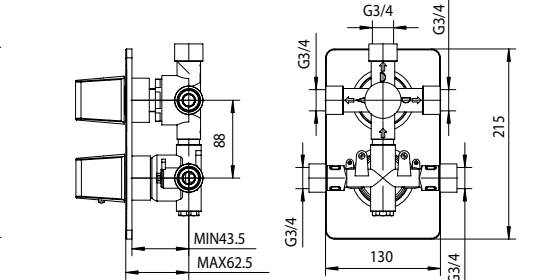
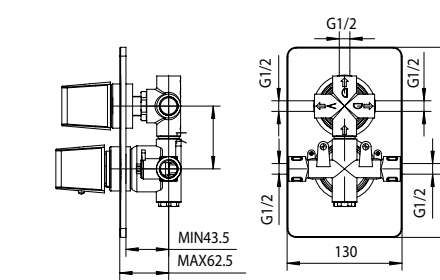
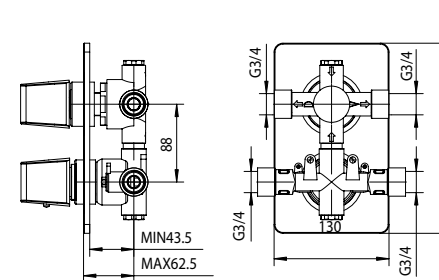
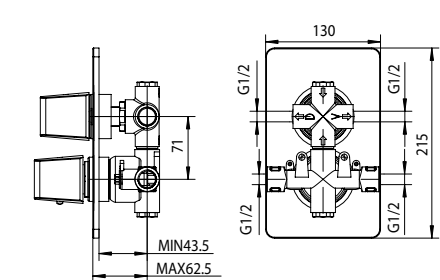
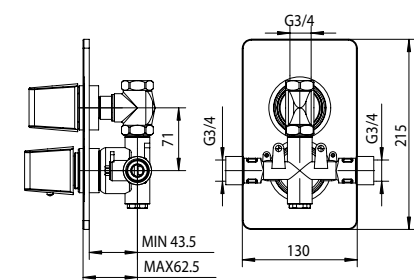
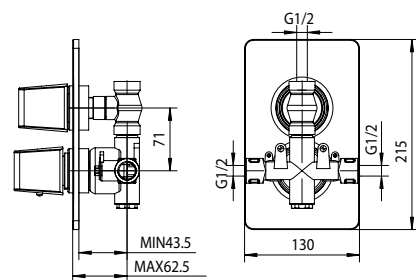
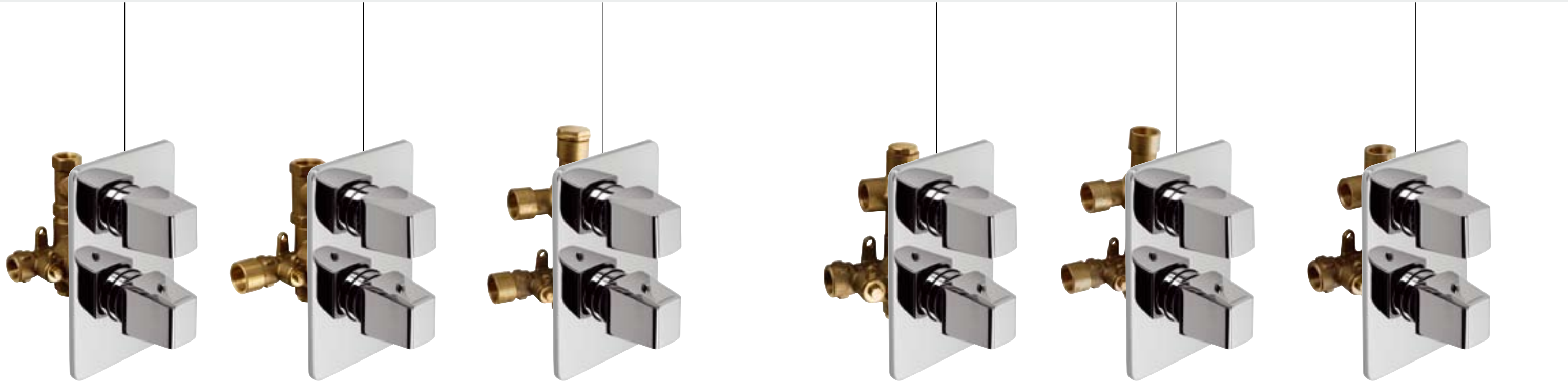

UNICO®, corpo per miscelatore termostatico da 1/2" con rubinetto da 1/2" a dischi in ceramica a 180°.

UNICO®, body for 1/2" thermostatic mixer, concealed installation, with built-in 1/2" ceramic disc tap, 180°.

UNICO®, corps pour mitigeur thermostatique 1/2" à encaster, avec robinet 1/2" à disques en céramique, 180°.

UNICO®, Körper für Unterputz 1/2" Thermostat-Mischer mit 1/2" Keramische Scheiben Absperrventil 180°.

UNICO®, cuerpo de mezclador termostático 1/2" empotrable, con grifo 1/2" con discos de cerámica 180°.

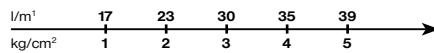

10 € 165,00

992771

[unico]



Solo parti esterne - Exposed parts only
Parties extérieures seule - Aufputzteile
Partes externas

10 € 209,00

UNICO®, corpo per miscelatore termostatico da 3/4" con rubinetto da 3/4" a dischi in ceramica a 180°.

UNICO®, body for 3/4" thermostatic mixer, concealed installation, with built-in 3/4" ceramic disc tap, 180°.

UNICO®, corps pour mitigeur thermostatique 3/4" à encaster, avec robinet 3/4" à disques en céramique, 180°.

UNICO®, Körper für Unterputz 3/4" Thermostat-Mischer mit 3/4" Keramische Scheiben Absperrventil 180°.

UNICO®, cuerpo de mezclador termostático 3/4" empotrable, con grifo 3/4" con discos de cerámica 180°.

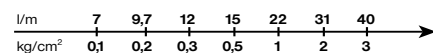

10 € 185,00

992772

[unico]



Solo parti esterne - Exposed parts only
Parties extérieures seule - Aufputzteile
Partes externas

10 € 209,00

UNICO®, corpo per miscelatore termostatico 1/2" da incasso con deviatore a dischi in ceramica a 2 uscite e funzione di stop.

UNICO®, body for 1/2" thermostatic mixer, concealed installation, with 2 outlets diverter, ceramic discs and stop function.

UNICO®, corps pour mitigeur thermostatique à encaster 1/2" inverseur à disques en céramique 2 sorties et avec fonction de stop.

UNICO®, Körper für Unterputz 1/2" Thermostat-Mischer mit Keramik 2-Wegeumsteller mit Stop-Position.

UNICO®, cuerpo de mezclador termostático 1/2" empotrable con desviador con discos de cerámica a 2 salidas con stop.

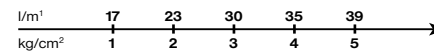

10 € 205,00

992773

[unico]



Solo parti esterne - Exposed parts only
Parties extérieures seule - Aufputzteile
Partes externas

10 € 209,00

UNICO®, corpo per miscelatore termostatico 3/4" da incasso con deviatore a dischi in ceramica a 2 uscite e funzione di stop.

UNICO®, body for 3/4" thermostatic mixer, concealed installation, with 2 outlets diverter, ceramic discs and stop function.

UNICO®, corps pour mitigeur thermostatique à encaster 3/4" avec inverseur à disques en céramique, 2 sorties et avec fonction de stop.

UNICO®, Körper für Unterputz 3/4" Thermostat-Mischer mit Keramik 2-Wegeumsteller mit Stop-Position.

UNICO®, cuerpo de mezclador termostático 3/4" empotrable con desviador con discos de cerámica a 2 salidas con stop.

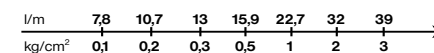

10 € 280,00

992774

[unico]



Solo parti esterne - Exposed parts only
Parties extérieures seule - Aufputzteile
Partes externas

10 € 209,00

UNICO®, corpo per miscelatore termostatico 1/2" da incasso con deviatore a dischi in ceramica a 3 uscite e funzione di stop.

UNICO®, body for 1/2" thermostatic mixer, concealed installation, with 3 outlets diverter, ceramic discs and stop function.

UNICO®, corps pour mitigeur thermostatique à encaster 1/2" avec inverseur à disques en céramique, 3 sorties et avec fonction de stop.

UNICO®, Körper für Unterputz 1/2" Thermostat-Mischer mit Keramik 3-Wegeumsteller mit Stop-Position.

UNICO®, cuerpo de mezclador termostático 1/2" empotrable con desviador con discos de cerámica a 3 salidas con stop.

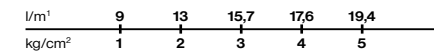

10 € 225,00

992775

[unico]



Solo parti esterne - Exposed parts only
Parties extérieures seule - Aufputzteile
Partes externas

10 € 209,00

UNICO®, corpo per miscelatore termostatico 3/4" da incasso con deviatore a dischi in ceramica a 3 uscite e funzione di stop.

UNICO®, body for 3/4" thermostatic mixer, concealed installation, with 3 outlets diverter, ceramic discs and stop function.

UNICO®, corps pour mitigeur thermostatique à encaster 3/4" avec inverseur à disques en céramique, 3 sorties et avec fonction de stop.

UNICO®, Körper für Unterputz 3/4" Thermostat-Mischer mit Keramik 3-Wegeumsteller mit Stop-Position.

UNICO®, cuerpo de mezclador termostático 3/4" empotrable con desviador con discos de cerámica a 3 salidas con stop.

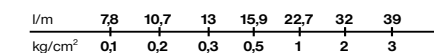

10 € 285,00

992776

[unico]



Solo parti esterne - Exposed parts only
Parties extérieures seule - Aufputzteile
Partes externas

10 € 209,00

212500



212501



212502



212503



212504



212505

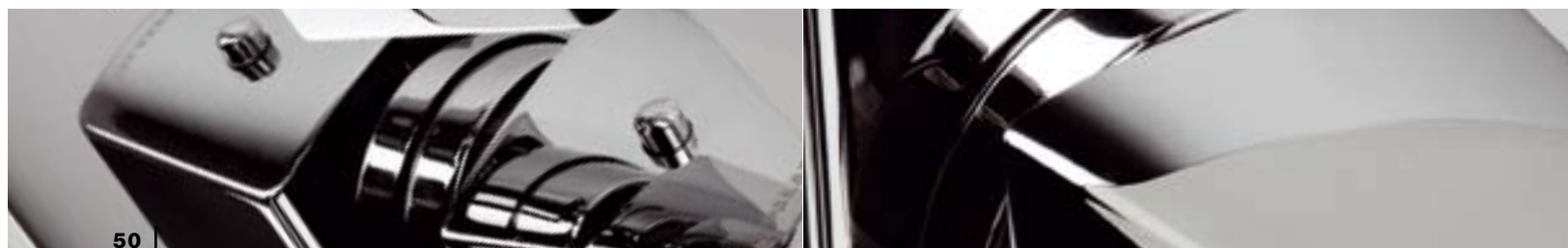

clickclick

mis

mis



mis



finiture disponibili
available finishes
finition disponibles
verfügbare Farben
acabados disponibles

10 Cromo - Chrome
Chromé - Chrom





Miscelatore monocomando per lavabo con scarico da 1" 1/4.
 Single control mixer for washbasin, with pop-up waste 1" 1/4.
 Mitigeur monocommande de lavabo, avec vidage 1" 1/4.
 Waschtisch Einhebelmischer mit Ablaufgarnitur 1" 1/4.
 Mezclador monomando para lavabo, con desagüe 1" 1/4.

Miscelatore monocomando per lavabo senza scarico.
 Single control mixer for washbasin, without waste.
 Mitigeur monocommande de lavabo, sans vidage.
 Waschtisch Einhebelmischer ohne Ablaufgarnitur.
 Mezclador monomando para lavabo, sin desagüe.

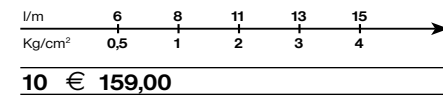

10 € 159,00

563010

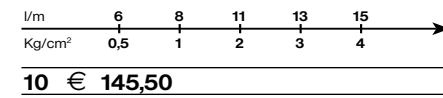
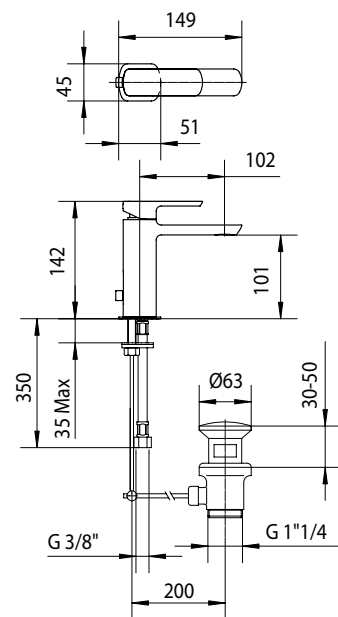

10 € 145,50

563011

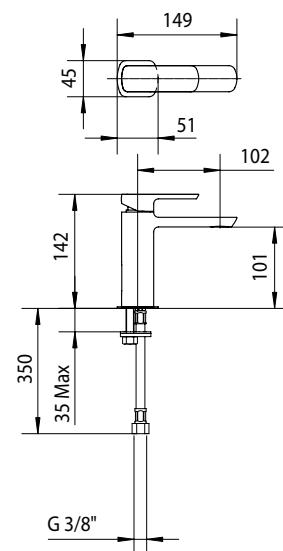

Miscelatore monocomando per lavabo con scarico da 1" 1/4, bocca prolungata 122 mm.
 Single control mixer for washbasin, with pop-up waste 1" 1/4, extended spout 122 mm.
 Mitigeur monocommande de lavabo, avec vidage 1" 1/4, bec 122 mm.
 Waschtisch Einhebelmischer mit Ablaufgarnitur 1" 1/4, Auslauf 122 mm.
 Mezclador monomando para lavabo, con desagüe 1" 1/4, caño prolongado mm 122.

Miscelatore monocomando per lavabo senza scarico, con bocca prolungata 122 mm.
 Single control mixer for washbasin, without waste, extended spout 122 mm.
 Mitigeur monocommande de lavabo, sans vidage, bec 122 mm.
 Waschtisch Einhebelmischer ohne Ablaufgarnitur, Auslauf 122 mm.
 Mezclador monomando para lavabo, sin desagüe, caño prolongado mm 122.

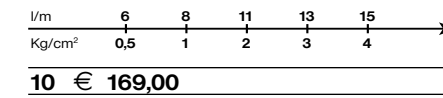

10 € 169,00

563083

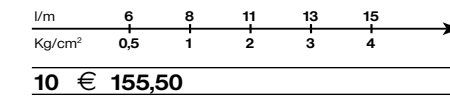
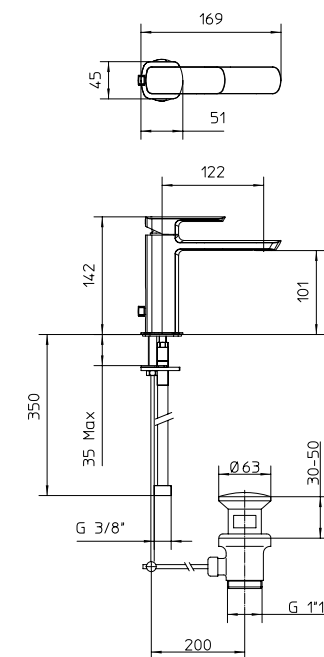

10 € 155,50

563084

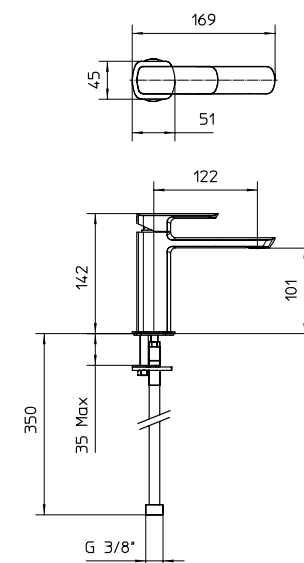

mis



mis mis

Miscelatore monocomando per lavabo con scarico da 1" 1/4, bocca prolungata 202 mm.

Single control mixer for washbasin, with pop-up waste 1" 1/4, extended spout 202 mm.

Mitigeur monocommande de lavabo, avec vidage 1" 1/4, bec 202 mm.

Waschtisch Einhebelmischer mit Ablaufgarnitur 1" 1/4, Auslauf 202 mm.

Mezclador monomando para lavabo, con desagüe 1" 1/4, caño prolongado mm 202.

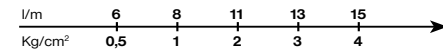

10 € 225,00

563038

Miscelatore monocomando per lavabo senza scarico, con bocca prolungata 202 mm.

Single control mixer for washbasin, without waste, extended spout 202 mm.

Mitigeur monocommande de lavabo, sans vidage, bec 202 mm.

Waschtisch Einhebelmischer ohne Ablaufgarnitur, Auslauf 202 mm.

Mezclador monomando para lavabo, sin desagüe, caño prolongado mm 202.

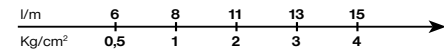

10 € 211,50

563045

Miscelatore monocomando alto per lavabo con scarico 1" 1/4.

Tall single control mixer for washbasin, with pop-up waste 1" 1/4.

Mitigeur monocommande haut de lavabo, avec vidage 1" 1/4.

Hoch Waschtisch Einhebelmischer mit Ablaufgarnitur 1" 1/4.

Mezclador monomando alto para lavabo con desagüe 1" 1/4.

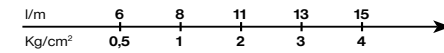

10 € 250,00

563013

Miscelatore monocomando alto per lavabo senza scarico.

Tall single control mixer for washbasin, without waste.

Mitigeur monocommande haut de lavabo, sans vidage.

Hoch Waschtisch Einhebelmischer ohne Ablaufgarnitur.

Mezclador monomando alto para lavabo, sin desagüe.

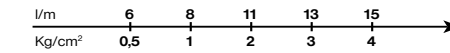

10 € 236,50

563018

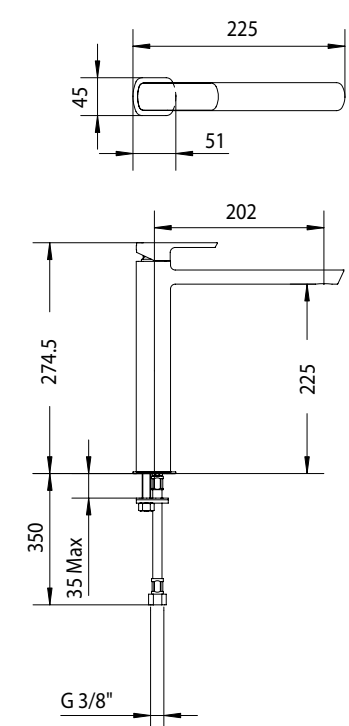
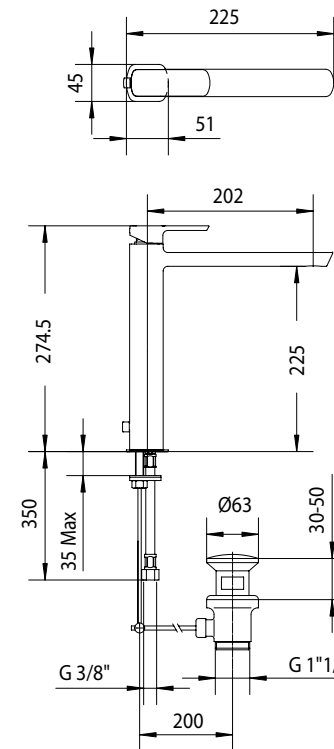
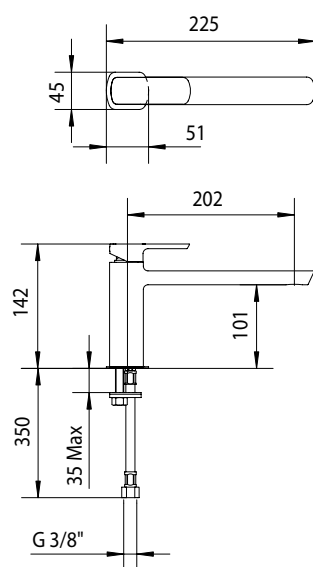
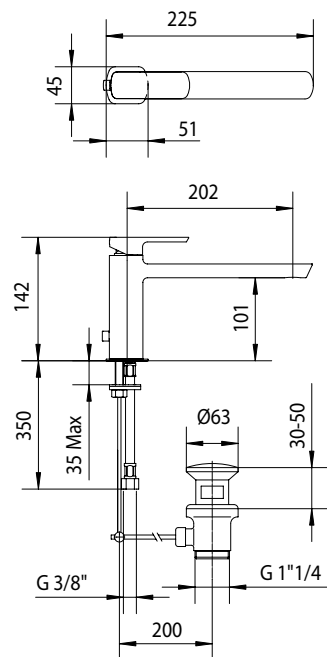

mis mis

Miscelatore monocomando da incasso, per lavabo.
 Single control mixer for washbasin, concealed installation.
 Mitigeur monocommande à encastrer mural pour lavabo.
 Einhebelmischer für Waschtisch, Unterputz.
 Mezclador monomando empotrable para lavabo.

Miscelatore monocomando per bidet con scarico 1" 1/4.
 Single control mixer for bidet, with pop up waste 1" 1/4.
 Mitigeur monocommande de bidet, avec vidage 1" 1/4.
 Bidet Einhebelmischer mit Ablaufgarnitur 1" 1/4.
 Mezclador monomando para bidet con desagüe 1" 1/4.

Miscelatore monocomando per bidet senza scarico.
 Single control mixer for bidet, without waste.
 Mitigeur monocommande de bidet, sans vidage.
 Bidet Einhebelmischer ohne Ablaufgarnitur.
 Mezclador monomando para bidet sin desagüe.

Batteria bordo vasca 3 fori, vitoni a dischi in ceramica a 180°.
 Deck mounted 3 holes bath mixer, ceramic discs head valves 180°.
 Mélangeur à 3 trous sur gorge de baignoire, têtes céramiques 180°.
 Wannenrand-Fünflochbatterie mit keramischen Oberteile 180°.
 Batería de sobreponer para bañera 3 agujeros, con discos de cerámica 180°.

Batteria bordo vasca 5 fori con deviatore, doccia e flessibile, vitoni a dischi in ceramica a 180°.
 Deck mounted 5 holes bath mixer with diverter and shower kit, ceramic discs head valves 180°.
 Mélangeur à 5 trous sur gorge de baignoire avec inverseur et combiné de douche, têtes céramiques 180°.
 Wannenrand-Fünflochbatterie mit Umsteller, Brausegarnitur, mit keramischen Oberteile 180°.
 Batería de sobreponer para bañera 5 agujeros, flexible y ducha de mano, con discos de cerámica 180°.

l/m	6	8	11	13	15
Kg/cm ²	0,5	1	2	3	4
10 € 199,00					

l/m	6	8	11	13	15
Kg/cm ²	0,5	1	2	3	4
10 € 165,00					

l/m	6	8	11	13	15
Kg/cm ²	0,5	1	2	3	4
10 € 151,50					

l/m	17,5	24	34	40	47
Kg/cm ²	0,5	1	2	3	4
10 € 358,00					

l/m	11	16	22	27	30
Kg/cm ²	0,5	1	2	3	4
10 € 498,00					

563081

564010

564011

011013

011384

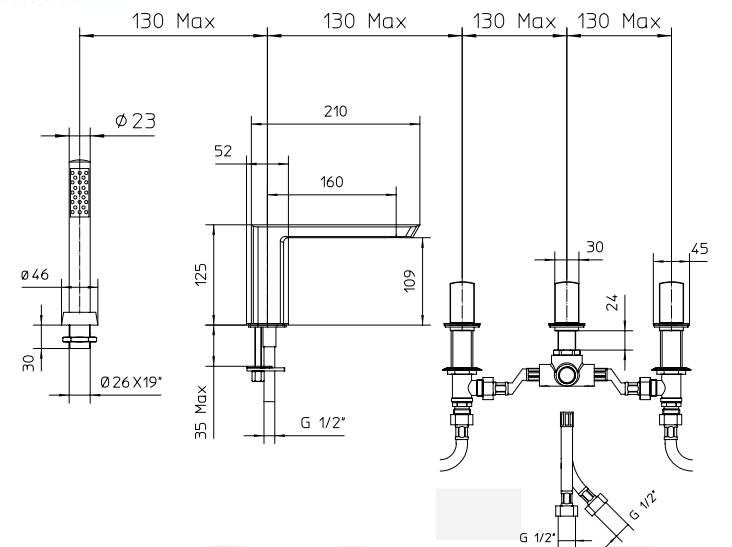
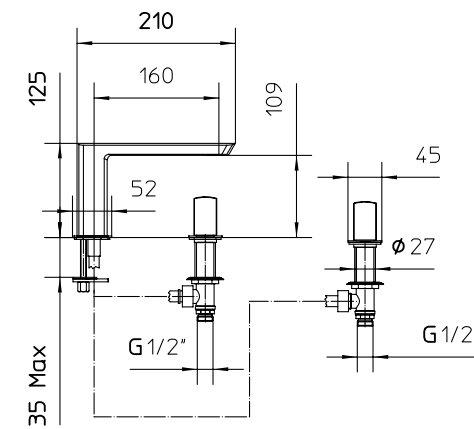
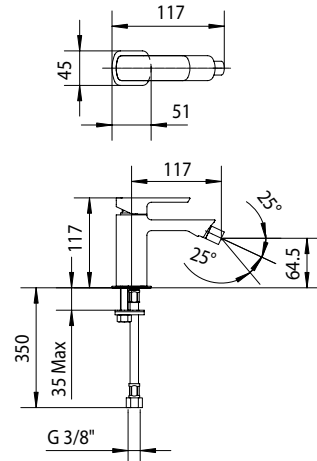
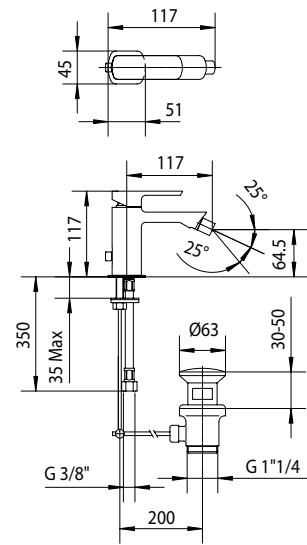
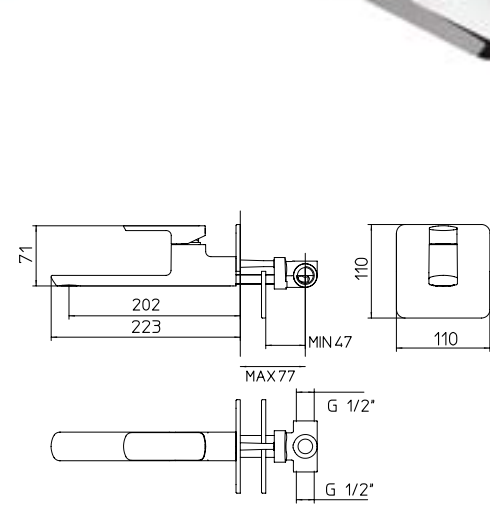

Miscelatore monocomando per vasca con bocca-deviatore, supporto doccia integrato, supporto doccia orientabile, flessibile Gliss 1,5 m e doccetta.

Wall mounted bath-shower mixer, with diverter spout, built-in shower bracket, wall mounted swivel bracket with Gliss flexible tube 1,5 m and handshower.

Mitigeur monocommande de bain-douche, bec inverseur, avec support douche incorporé, flexible Gliss 1,5 m, douchette et support mural orientable.

Bade-Einhebelmischer mit Umsteller-Auslauf, Aufputz, eingebautem Brausehalter mit Gliss Brauseschlauch 1,5 m, Handbrause und verstellbarer Brausehalter.

Mezclador monomando para bañera con caño desviador, soporte de ducha integrado, soporte de ducha orientable, flexible Gliss 1,5 m y ducha de mano.

l/m ¹	6	9	12	15	17
kg/cm ²	0,5	1	2	3	4

10 € 310,00

Miscelatore monocomando per vasca con bocca-deviatore, supporto doccia integrato, flessibile Gliss 1,5 m e doccetta.

Wall mounted bath-shower mixer, with diverter spout, built-in shower bracket, Gliss flexible tube 1,5 m and handshower.

Mitigeur monocommande de bain-douche, bec inverseur, avec support douche incorporé, flexible Gliss 1,5 m, douchette.

Bade-Einhebelmischer mit Umsteller-Auslauf, Aufputz, eingebautem Brausehalter mit Gliss Brauseschlauch 1,5 m und Handbrause.

Mezclador monomando para bañera con caño desviador, soporte de ducha integrado, flexible Gliss 1,5 m y ducha de mano.

l/m ¹	6	9	12	15	17
kg/cm ²	0,5	1	2	3	4

10 € 300,00

Miscelatore monocomando per vasca con bocca-deviatore, supporto doccia integrato, senza flessibile né doccetta.

Wall mounted bath-shower mixer with diverter spout, built-in shower bracket, without shower kit.

Mitigeur monocommande de bain-douche, bec inverseur, avec support douche incorporé, sans douchette ni flexible.

Bade-Einhebelmischer mit Umsteller-Auslauf, Aufputz, eingebautem Brausehalter ohne Handbrause und ohne Brauseschlauch.

Mezclador monomando para bañera con caño desviador, soporte de ducha integrado, sin flexible ni ducha de mano.

l/m ¹	6	9	12	15	17
kg/cm ²	0,5	1	2	3	4

10 € 260,00

561012

561025

561015

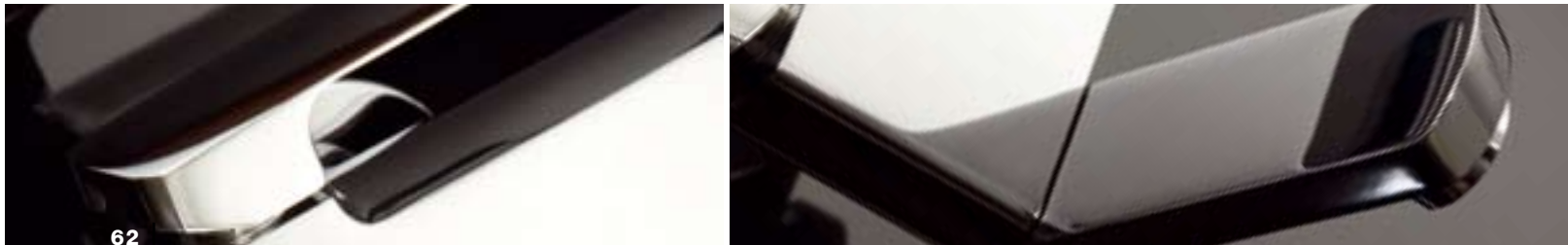
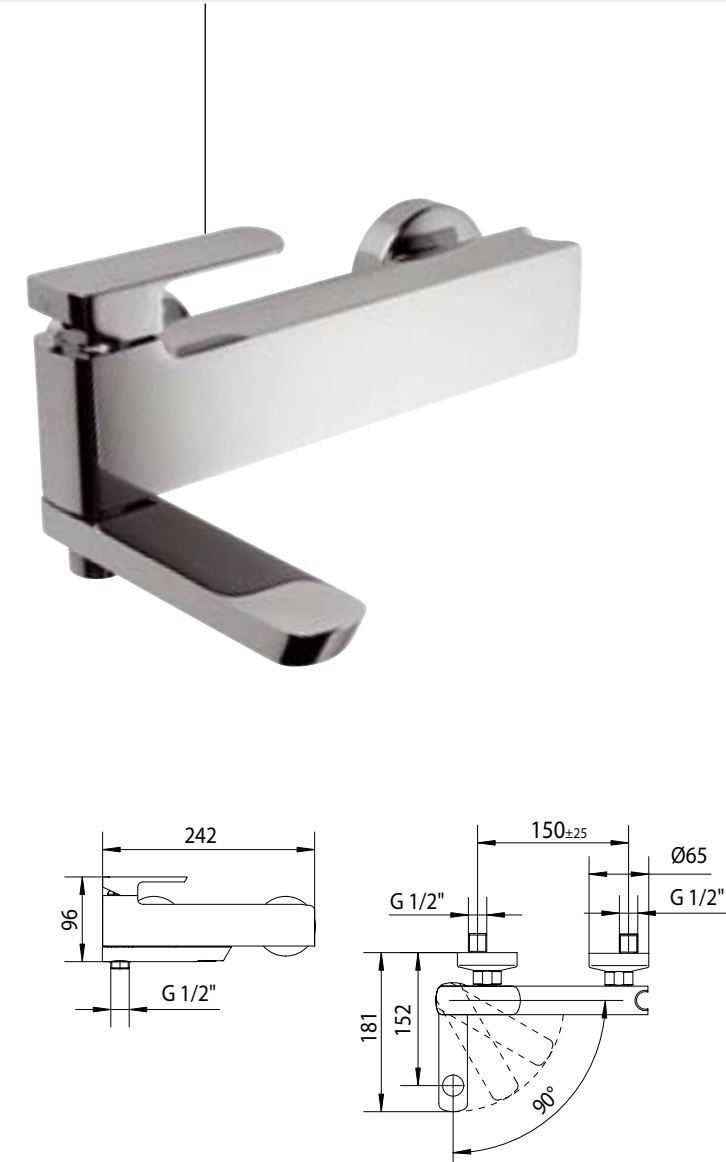
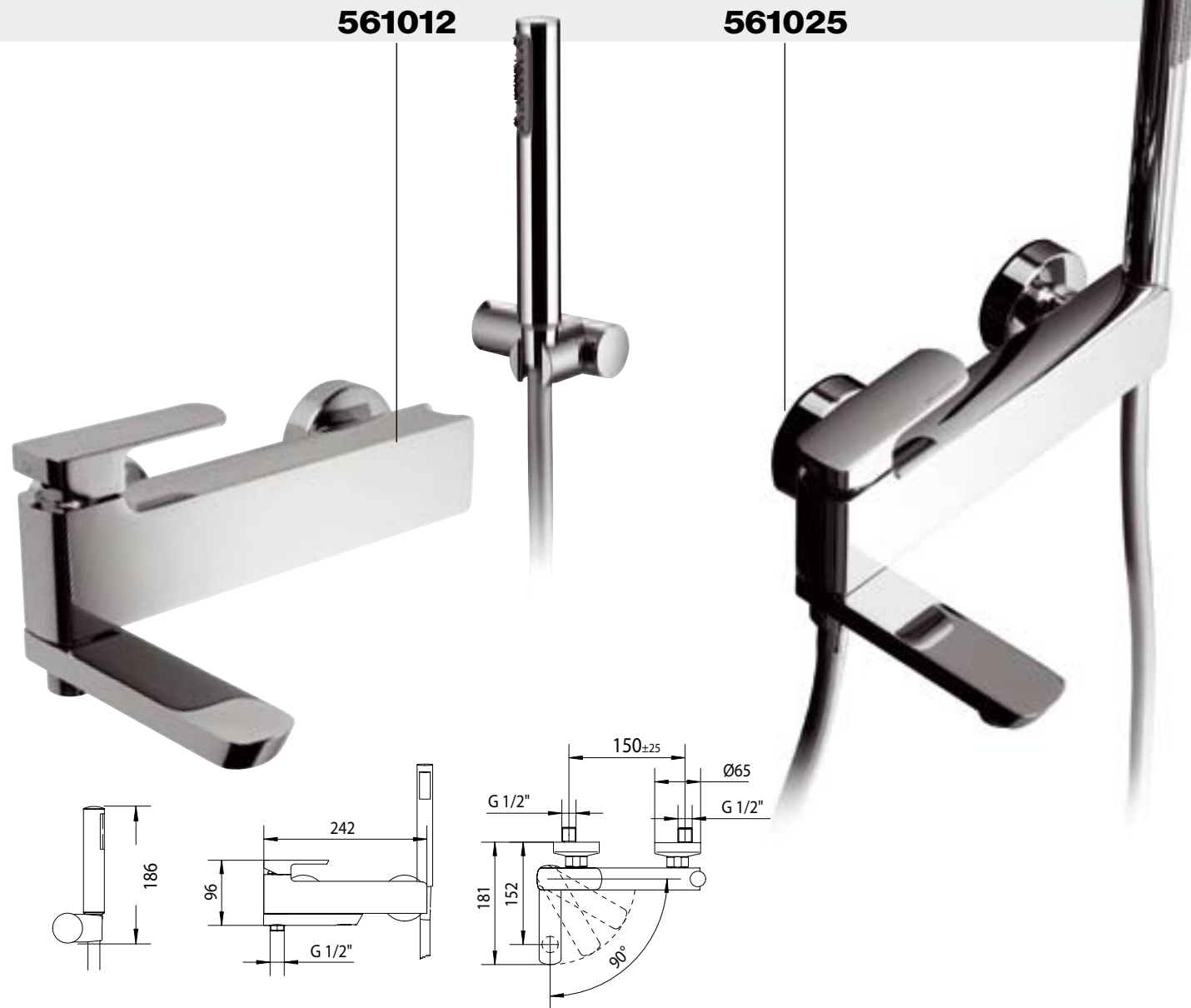

mis mis

Miscelatore monocomando per doccia, supporto doccia integrato, supporto doccia orientabile, flessibile Gliss 1,5 m e doccia.

Wall mounted shower mixer, built-in shower bracket, wall mounted swivel bracket, Gliss flexible tube 1,5 m and handshower.

Mitigeur monocommande de douche avec support douche incorporé, douchette, flexible Gliss 1,5 m et support mural orientable.

Brause-Einhebelmischer, Aufputz mit eingebautem Brausehalter mit Gliss Brause-schlauch 1,5 m, Handbrause und verstellbarer Brausehalter.

Mezclador monomando para ducha, soporte de ducha integrado, soporte de ducha orientable, flexible Gliss 1,5 m y ducha de mano.

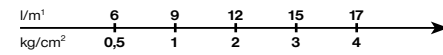

10 € 245,00

Miscelatore monocomando per doccia, supporto doccia integrato, con flessibile Gliss 1,5 m e doccia.

Wall mounted shower mixer, built-in shower bracket, with Gliss flexible tube 1,5 m and handshower.

Mitigeur monocommande de douche avec support douche incorporé, avec flexible Gliss 1,5 m et douchette.

Bade-Einhebelmischer, Aufputz mit eingebautem Brausehalter, Gliss Brause-schlauch 1,5 m und Handbrause.

Mezclador monomando para ducha, soporte de ducha integrado, flexible Gliss 1,5 m y ducha de mano.

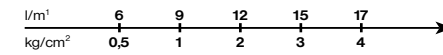

10 € 235,00

Miscelatore monocomando per doccia, supporto doccia integrato, senza flessibile né doccia.

Wall mounted shower mixer, built-in shower bracket, without shower kit.

Mitigeur monocommande de douche avec support douche incorporé, sans douchette ni flexible.

Brause-Einhebelmischer, Aufputz mit eingebautem Brausehalter ohne Handbrause und ohne Brauseschlauch.

Mezclador monomando para ducha, soporte de ducha integrado, sin flexible ni ducha de mano.

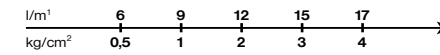

10 € 195,00

562020

562027

562026

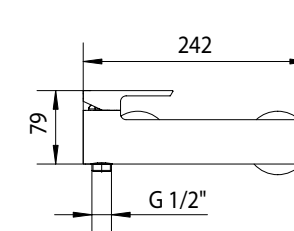
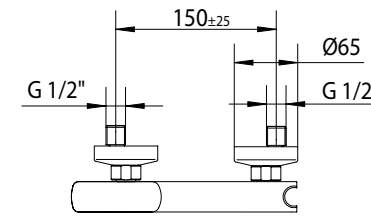
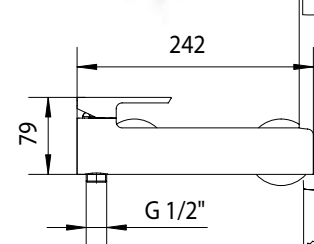
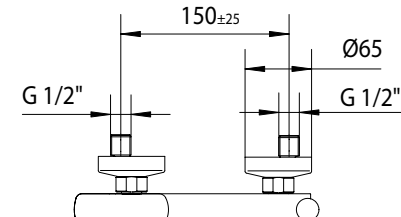
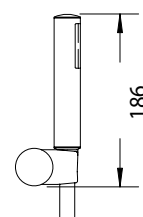

mis mis

Miscelatore monocomando da incasso completo per vasca-doccia con deviatore automatico.

Complete concealed single lever mixer for bath-shower with automatic diverter.

Mitigeur monocommande à encastrer complet pour bain-douche avec inverseur automatique.

Komplett Unterputz Wannenfüll und Brausebatterie mit Umsteller.

Mezclador monomando empotrable para baño-ducha completo con desviador automático.

l/m	11	15	21	26	29
Kg/cm ²	0,5	1	2	3	4

10 € 175,00

Miscelatore monocomando da incasso completo per doccia.

Complete concealed single lever mixer for shower.

Mitigeur monocommande complet à encastrer pour douche.

Komplett Unterputz Brausebatterie.

Mezclador monomando empotrable completo para ducha.

l/m	13	16	25	30	34
Kg/cm ²	0,5	1	2	3	4

10 € 95,00

561020



562010

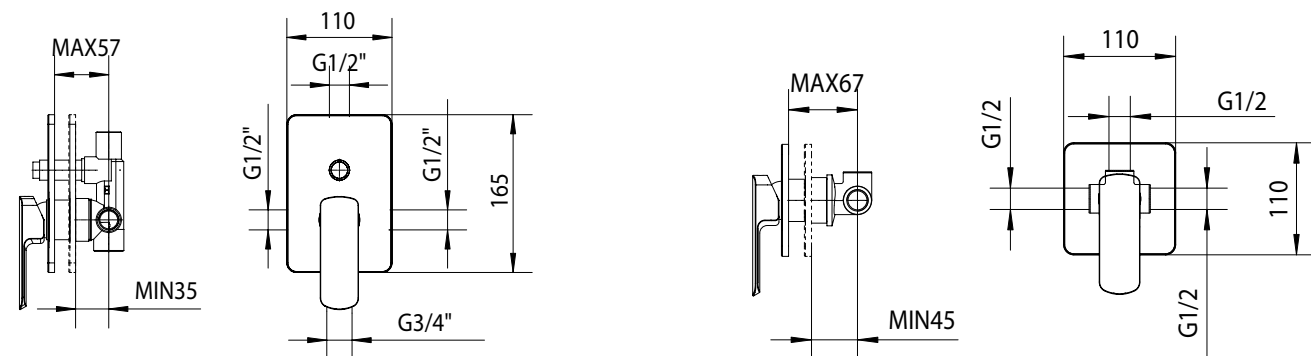

mis



mis mis

digit 2



digit 2



finiture disponibili
available finishes
finition disponibles
verfügbare Farben
acabados disponibles

10 Cromo - Chrome
Chromé - Chrom





Miscelatore monocomando alto per lavabo con scarico 1" 1/4 Click-Clack.

Tall single control mixer for washbasin, Click-Clack waste 1" 1/4.

Mitigeur monocommande haut de lavabo, avec vidage Click-Clack 1" 1/4.

Hoch Waschtisch Einhebelmischer mit Click-Clack Ablaufgarnitur 1" 1/4.

Mezclador monomando alto para lavabo con desagüe Click-Clack 1" 1/4.

Miscelatore monocomando alto per lavabo senza scarico.

Tall single control mixer for washbasin, without waste.

Mitigeur monocommande haut de lavabo, sans vidage.

Hoch Waschtisch Einhebelmischer ohne Ablaufgarnitur.

Mezclador monomando alto para lavabo, sin desagüe.

l/m	6	8	11	13	15
Kg/cm ²	0,5	1	2	3	4
10 € 205,00					

l/m	6	8	11	13	15
Kg/cm ²	0,5	1	2	3	4
10 € 170,00					

Miscelatore monocomando per bidet con scarico 1" 1/4.

Single control mixer for bidet, with pop up waste 1" 1/4.

Mitigeur monocommande de bidet, avec vidage 1" 1/4.

Bidet Einhebelmischer mit Ablaufgarnitur 1" 1/4.

Mezclador monomando para bidet con desagüe 1" 1/4.

Miscelatore monocomando per bidet senza scarico.

Single control mixer for bidet, without waste.

Mitigeur monocommande de bidet, sans vidage.

Bidet Einhebelmischer ohne Ablaufgarnitur.

Mezclador monomando para bidet sin desagüe.

Miscelatore monocomando per bidet, bocca fissa con scarico 1" 1/4.

Single control mixer for bidet, fixed spout with pop-up waste 1" 1/4.

Mitigeur monocommande de bidet, bec fixe avec vidage 1" 1/4.

Bidet Einhebelmischer mit Auslauf und Ablaufgarnitur 1" 1/4.

Mezclador monomando para bidet, caño fijo con desagüe 1" 1/4.

l/m ³	6	12	16	20	24
kg/cm ²	0,5	1	2	3	4
10 € 101,00					

l/m ³	6	12	16	20	24
kg/cm ²	0,5	1	2	3	4
10 € 91,00					

l/m ³	6	12	16	20	24
kg/cm ²	0,5	1	2	3	4
10 € 171,00					

103077

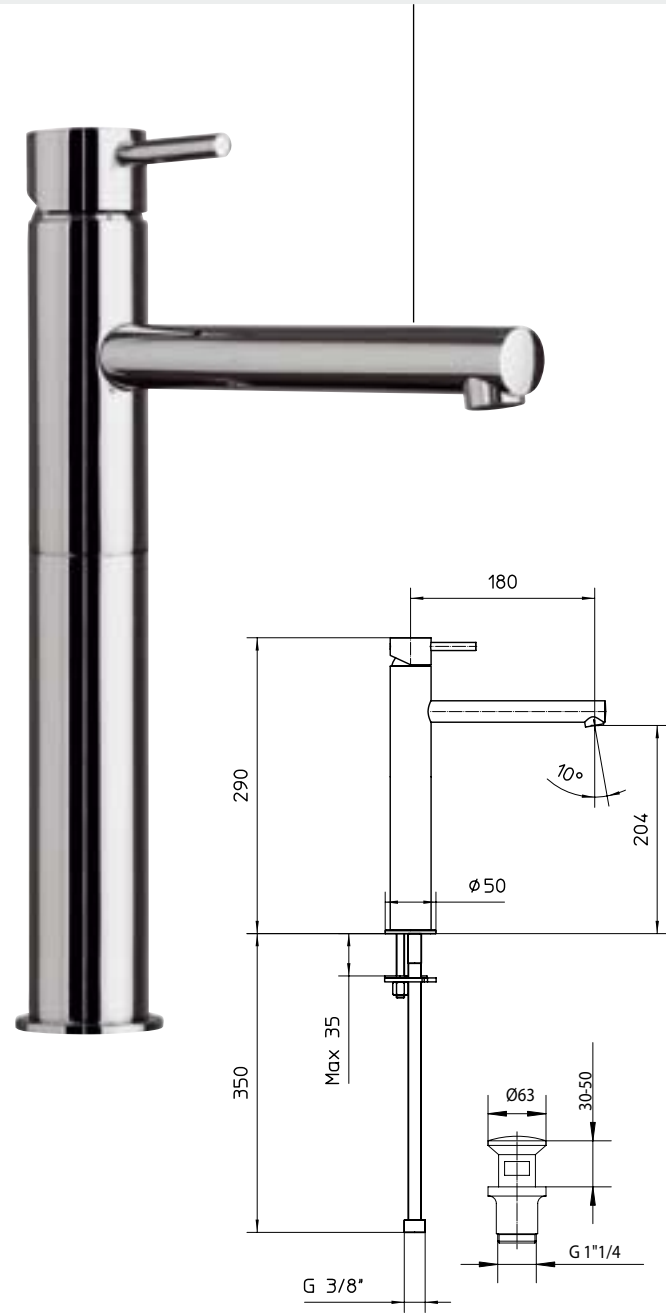

103018

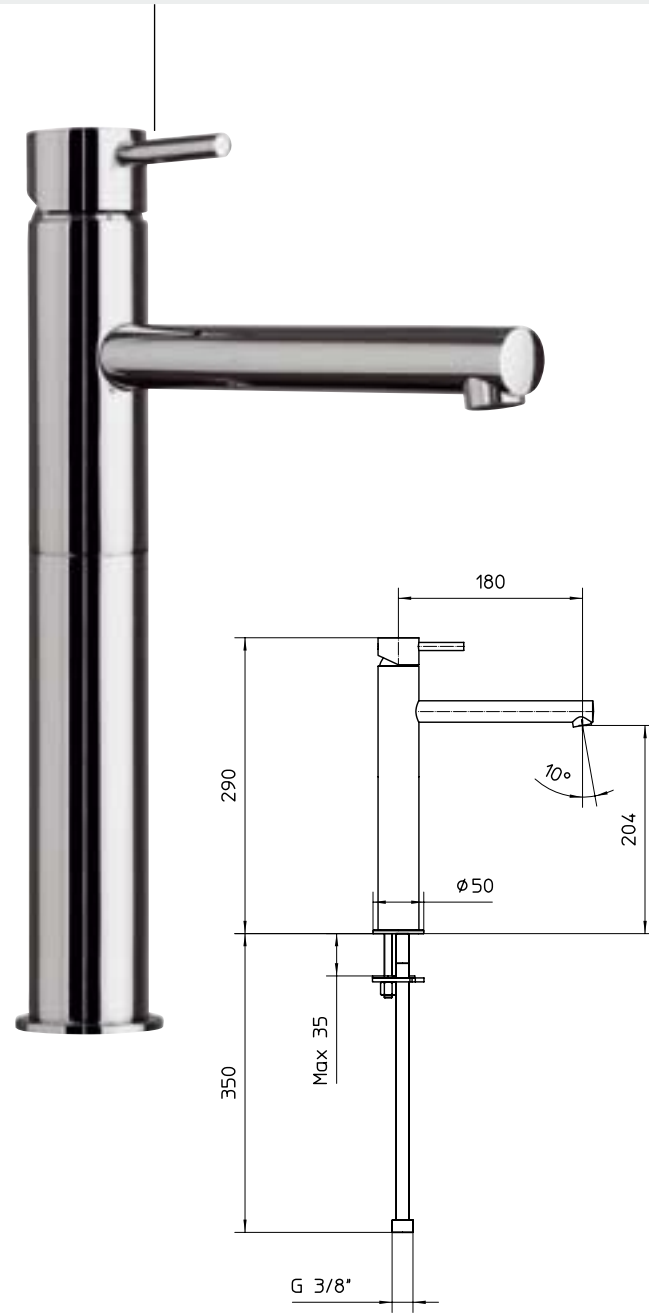

104010



104011



124043



digit 2

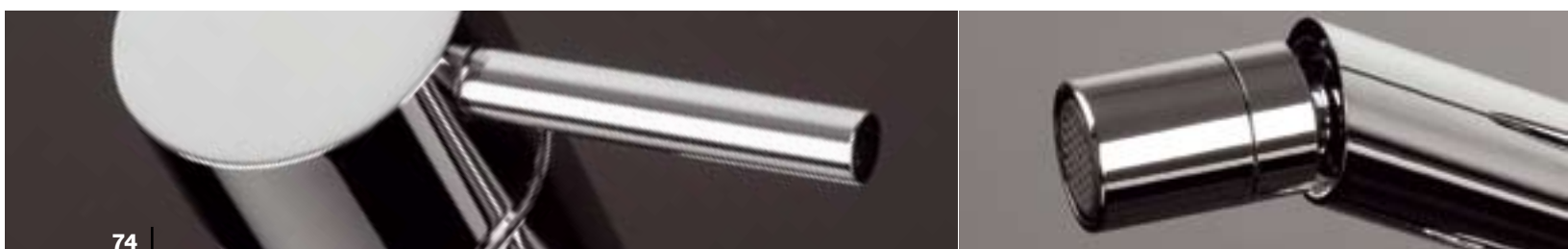

digit 2

Miscelatore monocomando per vasca con deviatore, supporto doccia orientabile, flessibile 1,5 m e doccia.

Wall mounted bath-shower mixer, with diverter, swivel bracket with flexible tube 1,5 m and handshower.

Mitigeur monocommande de bain-douche, flexible 1,5 m, douchette et support mural orientable.

Einhebelmischer als Wannenföüllbatterie mit verstellbarer Brausehalter, Handbrause und Brauseschlauch 1,5 m.

Mezclador monomando para bañera con desviador, soporte de ducha orientable, flexible 1,5 m y ducha de mano.

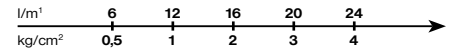

10 € 212,00

Miscelatore monocomando per vasca con deviatore, supporto doccia fisso, flessibile 1,5 m e doccia.

Wall mounted bath-shower mixer, with diverter, fixed bracket with flexible tube 1,5 m and handshower.

Mitigeur monocommande de bain-douche, flexible 1,5 m, douchette et support mural fixe.

Einhebelmischer als Wannenföüllbatterie mit Brausehalter, Handbrause und Brauseschlauch 1,5 m.

Mezclador monomando para bañera con desviador, soporte de ducha fijo, flexible 1,5 m y ducha de mano.

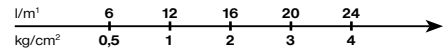

10 € 202,00

Miscelatore monocomando per vasca con deviatore, senza flessibile né doccia.

Wall mounted bath-shower mixer with diverter, without shower kit.

Mitigeur monocommande de bain-douche sans douchette ni flexible.

Einhebelmischer als Wannenföüllbatterie mit Umsteller ohne Handbrause und ohne Brauseschlauch.

Mezclador monomando para bañera con desviador, sin flexible ni ducha de mano.

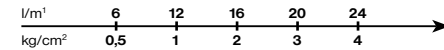

10 € 172,00

Kit sopra bordo vasca composto da miscelatore monocomando, deviatore a due vie, bocca e doccia.

Deck mounted kit composed by single control mixer two-ways diverter, spout and handshower.

Jeu sur gorge composé par mitigeur monocommande, inverseur à deux voies, bec et douchette.

Set für Wannenrandbatterie, bestehend aus: Einhebelmischer mit Umstellung, Auslauf, und Handbrause.

Kit de sobreponer compuesto por mezclador monomando con desviador, caño y ducha de mano.

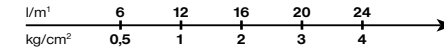

10 € 360,00

101012

101010

101015

121089

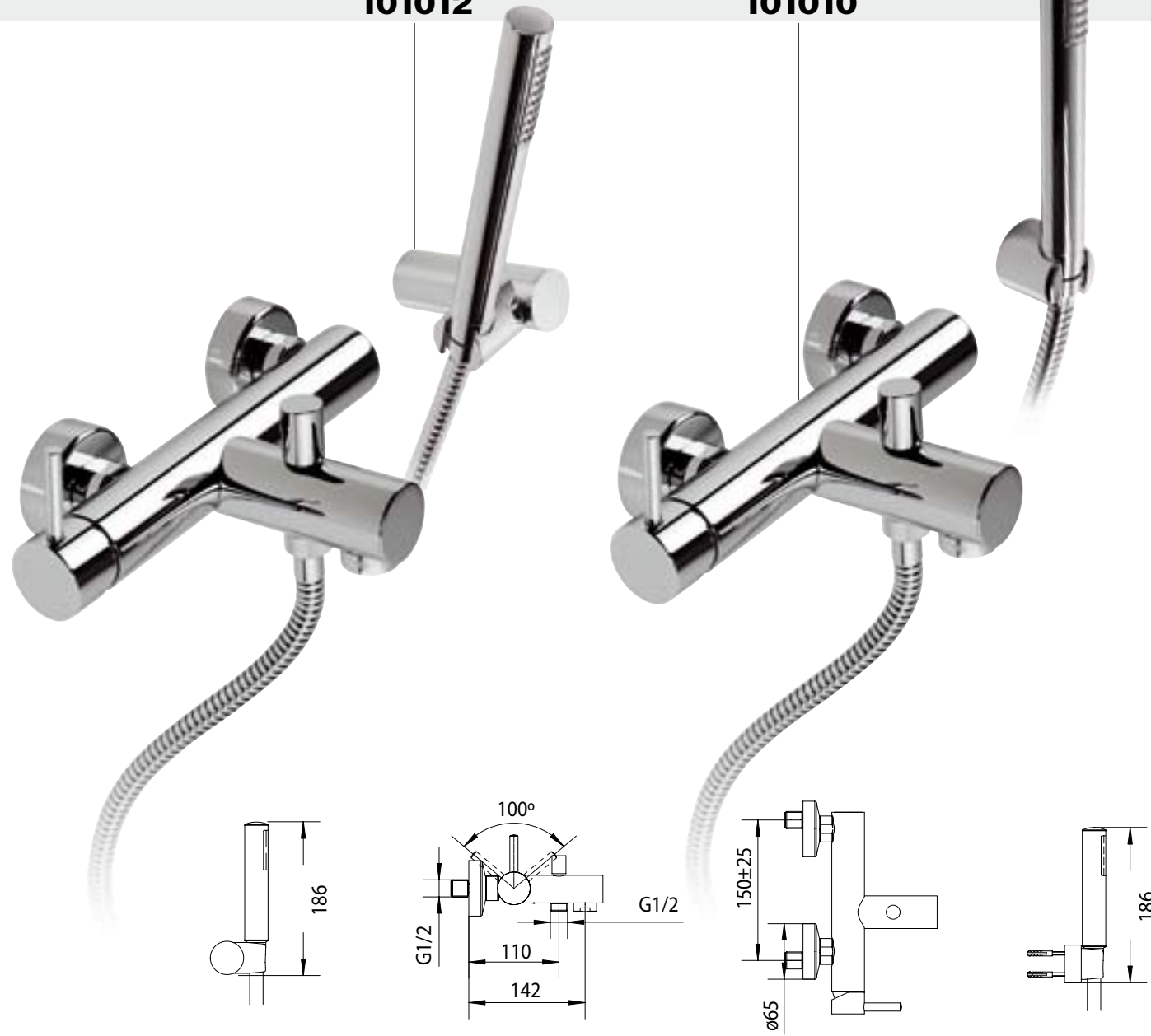

digit 2

Miscelatore monocomando per doccia, supporto orientabile, flessibile 1,5 m e doccia.

Wall mounted shower mixer, swivel bracket, flexible tube 1,5 m and handshower.

Mitigeur monocommande de douche, avec douchette, flexible 1,5 m et support mural orientable.

Einhebelmischer als Brausebatterie mit verstellbarer Brausehalter, Handbrause, und Brauseschlauch 1,5 m.

Mezclador monomando para ducha, soporte de ducha orientable, flexible 1,5 m y ducha de mano.

l/m ¹	6	12	16	20	24
kg/cm ²	0,5	1	2	3	4
10 € 155,00					

Miscelatore monocomando per doccia, senza flessibile né doccia.

Wall mounted shower mixer, without shower kit.

Mitigeur monocommande de douche, sans douchette ni flexible.

Brause-Einhebelmischer, Aufputz, ohne Handbrause und ohne Brauseschlauch.

Mezclador monomando para ducha, sin flexible ni ducha de mano.

l/m ¹	6	12	16	20	24
kg/cm ²	0,5	1	2	3	4
10 € 115,00					

Miscelatore monocomando da incasso completo per doccia.

Complete concealed single lever mixer for shower.

Mitigeur monocommande complet à encastrer pour douche.

Komplett Unterputz Brausebatterie.

Mezclador monomando empotrable completo para ducha.

l/m ¹	13	16	25	30	34
kg/cm ²	0,5	1	2	3	4
10 € 75,00					

Miscelatore monocomando da incasso completo per vasca-doccia con deviatore automatico.

Complete concealed single lever mixer for bath shower with automatic diverter.

Mitigeur monocommande à encastrer complet pour bain-douche avec inverseur automatique.

Komplett Unterputz Wannenfüll und Brausebatterie mit Umsteller.

Mezclador monomando empotrable para baño-ducha completo con desviador automático.

l/m	11	15	21	26	29
kg/cm ²	0,5	1	2	3	4
10 € 145,00					

Raccordo da incasso per alimentazione flessibile e reggidoccia incorporato completo di doccia e flessibile.

Wall shower bracket with water delivery, flexible and shower.

Raccord pour flexible pour installations à encastrer avec support intégré complet de flexible et douchette.

Anschluss für Schlauch mit Brausehalter, Brauseschlauch und Handbrause.

Connexión para tubo flexible completo de flexible y ducha.

l/m ¹	9	13	18	23	26
kg/cm ²	0,5	1	2	3	4
10 € 68,50					

Bocca vasca murale con aeratore.

Wall mounted spout for bath-tub with aerator.

Bec mural pour baignoire avec aérateur.

Wanneneinlauf mit Luftsprudler.

Caño para bañera con aireador.

l/m	11	17	24	29	33
kg/cm ²	0,5	1	2	3	4
10 € 69,00					

102020

102015

102012

101022

991023

992112



digit 2

digit 2

Miscelatore termostatico per vasca con deviatore, supporto doccia orientabile, flessibile 1,5 m e doccia.

Thermostatic wall mounted bath-shower mixer, with diverter, swivel bracket, flexible tube 1,5 m and handshower.

Mitigeur thermostatique de bain-douche, flexible 1,5 m, douchette et support mural orientable.

Thermostat Wannenföüllbatterie mit verstellbarer Brausehalter, Handbrause, und Brauseschlauch 1,5 m.

Mezclador termostático para bañera con desviador, soporte de ducha orientable, flexible 1,5 m y ducha de mano.

l/m ¹	12	16	20	24	26
kg/cm ²	1	2	3	4	5
10 € 245,00					

Miscelatore termostatico per vasca con deviatore, senza flessibile né doccia.

Thermostatic wall mounted bath-shower mixer with diverter, without shower kit.

Mitigeur thermostatique de bain-douche sans douchette ni flexible.

Thermostat Wannenföüllbatterie ohne Handbrause und ohne Brauseschlauch.

Mezclador termostático para bañera con desviador, sin flexible ni ducha de mano.

l/m ¹	12	16	20	24	26
kg/cm ²	1	2	3	4	5
10 € 205,00					

Miscelatore termostatico per doccia, uscita inferiore 1/2".

Thermostatic mixer for shower, low outlet 1/2".

Mitigeur thermostatique pour douche, sortie inférieure 1/2".

Thermostat als Brausebatterie, 1/2" unterer Ausgang.

Mezclador termostático para ducha, salida baja 1/2".

l/m ¹	10	14	18	21	23
kg/cm ²	1	2	3	4	5
10 € 159,00					

Miscelatore termostatico per doccia, uscita superiore 3/4".

Thermostatic mixer for shower, upper side 3/4" outlet.

Mitigeur thermostatique de douche, sortie supérieure 3/4".

Thermostat als Brausebatterie, 3/4" oberer Ausgang.

Mezclador termostático para ducha, salida alta 3/4".

l/m ¹	10	14	18	21	23
kg/cm ²	1	2	3	4	5
10 € 159,00					

Miscelatore termostatico per doccia, uscita superiore 3/4", uscita inferiore 1/2".

Thermostatic mixer for shower, upper side 3/4" outlet, low outlet 1/2".

Mitigeur thermostatique de douche, sortie supérieure 3/4", sortie inférieure 1/2".

Thermostat als Brausebatterie, 3/4" oberer Ausgang, 1/2" unterer Ausgang.

Mezclador termostático para ducha, salida alta 3/4", salida baja 1/2".

l/m ¹	10	14	18	21	23
kg/cm ²	1	2	3	4	5
10 € 219,00					

961158

961159

962060

962063

962066

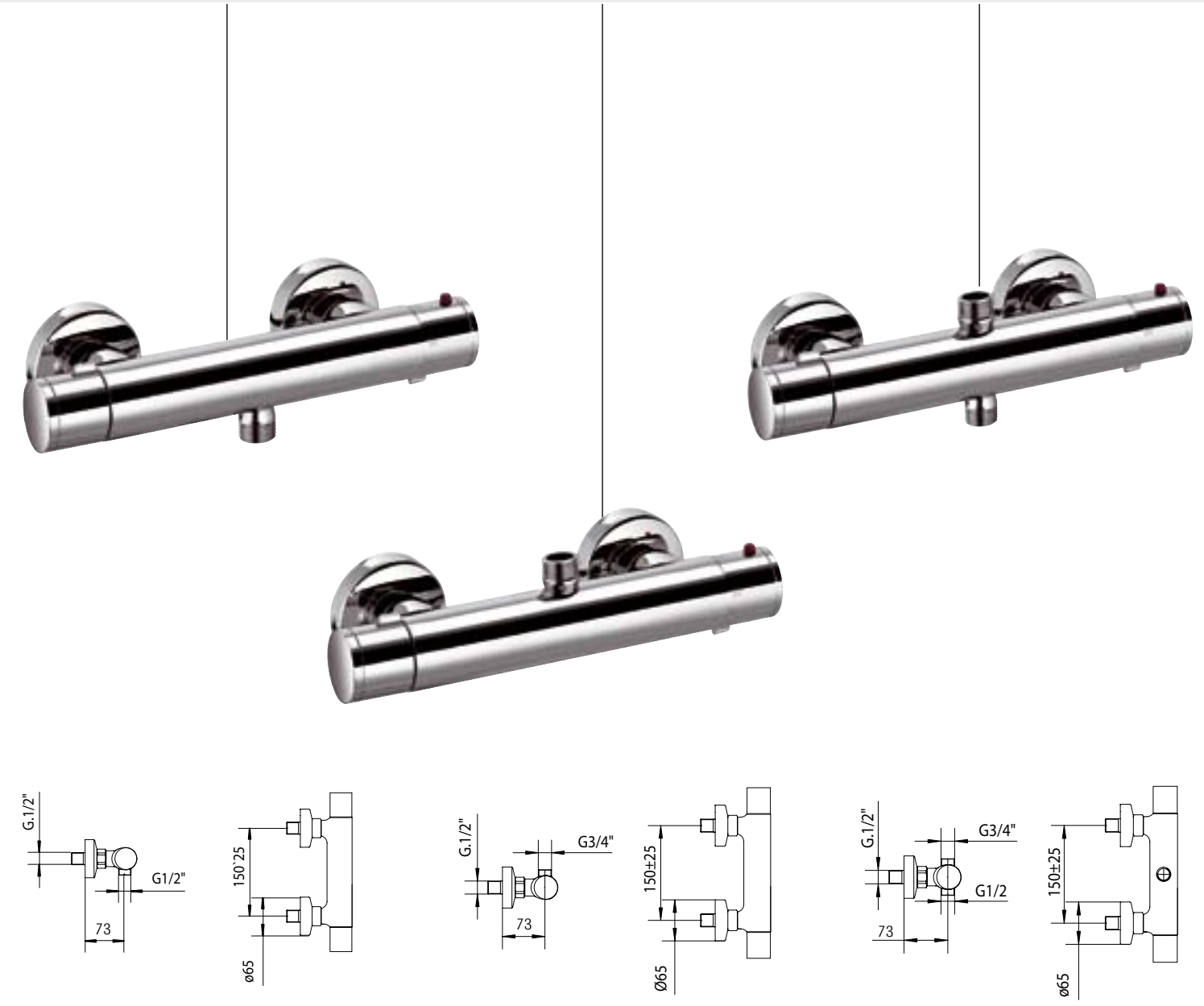

digit 2



digit 2

Miscelatore termostatico da incasso da **1/2"** con **rubinetto da 1/2"** a dischi in ceramica a 180°.

Concealed 1/2" thermostatic mixer with built-in 1/2" ceramic disc tap, 180°.

Mitigeur thermostatique 1/2" à encastrer, avec robinet 1/2" à disques en céramique, 180°.

Unterputz 1/2" Thermostat-Mischer mit 1/2" Keramische Scheiben Absperrventil 180°.

Mezclador termostático 1/2" empotrable, con grifo 1/2" con discos de cerámica 180°.

Miscelatore termostatico da incasso da **3/4"** con **rubinetto da 3/4"** a dischi in ceramica a 180°.

Concealed 3/4" thermostatic mixer with built-in 3/4" ceramic disc tap, 180°.

Mitigeur thermostatique 3/4" à encastrer, avec robinet 3/4" à disques en céramique, 180°.

Unterputz 3/4" Thermostat-Mischer mit 3/4" Keramische Scheiben Absperrventil 180°.

Mezclador termostático 3/4" empotrable, con grifo 3/4" con discos de cerámica 180°.

Miscelatore termostatico **1/2"** da incasso con deviatore a dischi in ceramica a **2 uscite** e funzione di stop.

1/2" thermostatic mixer, concealed installation with 2 outlets diverter, ceramic discs and stop function.

Mitigeur thermostatique à encastrer 1/2" avec inverseur à disques en céramique, 2 sorties et avec fonction de stop.

Unterputz 1/2" Thermostat-Mischer mit Keramik 2-Wegeumsteller mit Stop-Position.

Mezclador termostático 1/2" empotrable, desviador con discos de cerámica a 2 salidas con stop.

Miscelatore termostatico **3/4"** da incasso con deviatore a dischi in ceramica a **2 uscite** e funzione di stop.

3/4" thermostatic mixer, concealed installation with 2 outlets diverter, ceramic discs and stop function.

Mitigeur thermostatique à encastrer 3/4" avec inverseur à disques en céramique, 2 sorties et avec fonction de stop.

Unterputz 3/4" Thermostat-Mischer mit Keramik 2-Wegeumsteller mit Stop-Position.

Mezclador termostático 3/4" empotrable, desviador con discos de cerámica a 2 salidas con stop.

Miscelatore termostatico **1/2"** da incasso con deviatore a dischi in ceramica a **3 uscite** e funzione di stop.

1/2" thermostatic mixer, concealed installation with 3 outlets diverter, ceramic discs and stop function.

Mitigeur thermostatique à encastrer 1/2" avec inverseur à disques en céramique, 3 sorties et avec fonction de stop.

Unterputz 1/2" Thermostat-Mischer mit Keramik 3-Wegeumsteller mit Stop-Position.

Mezclador termostático 1/2" empotrable, desviador con discos de cerámica a 3 salidas con stop.

Miscelatore termostatico **3/4"** da incasso con deviatore a dischi in ceramica a **3 uscite** e funzione di stop.

3/4" thermostatic mixer, concealed installation with 3 outlets diverter, ceramic discs and stop function.

Mitigeur thermostatique à encastrer 3/4" avec inverseur à disques en céramique, 3 sorties et avec fonction de stop.

Unterputz 3/4" Thermostat-Mischer mit Keramik 3-Wegeumsteller mit Stop-Position.

Mezclador termostático 3/4" empotrable, desviador con discos de cerámica a 3 salidas con stop.

l/m	17	23	30	35	39
kg/cm ²	1	2	3	4	5
10	€ 240,00				

l/m	7	9,7	12	15	22	31	40
kg/cm ²	0,1	0,2	0,3	0,5	1	2	3
10	€ 260,00						

l/m	17	23	30	35	39
kg/cm ²	1	2	3	4	5
10	€ 280,00				

l/m	7,8	10,7	13	15,9	22,7	32	39
kg/cm ²	0,1	0,2	0,3	0,5	1	2	3
10	€ 355,00						

l/m	9	13	15,7	17,6	19,4
kg/cm ²	1	2	3	4	5
10	€ 300,00				

l/m	7,8	10,7	13	15,9	22,7	32	39
kg/cm ²	0,1	0,2	0,3	0,5	1	2	3
10	€ 360,00						

962410



962414



962425



962427



962426



962428

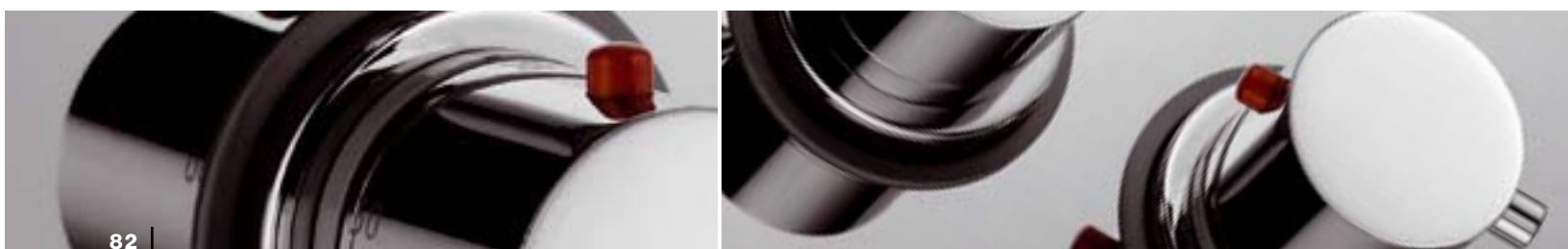
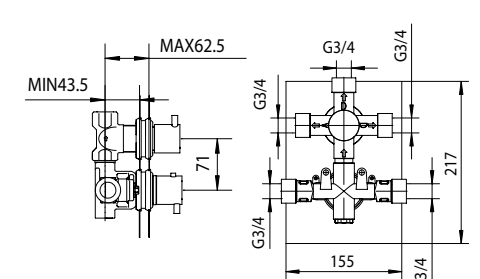
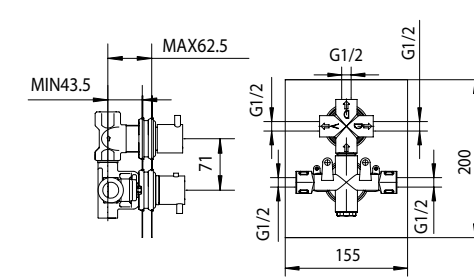
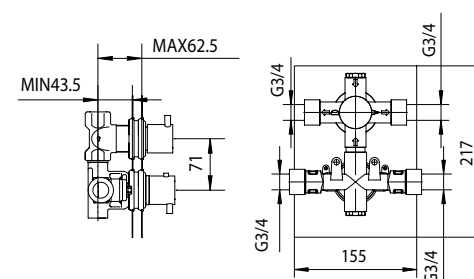
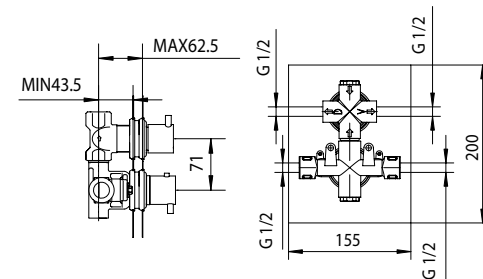
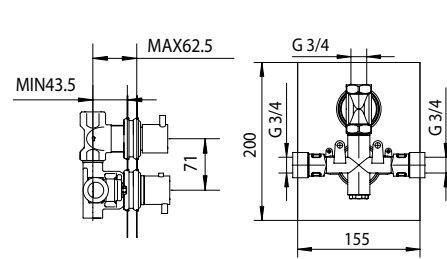
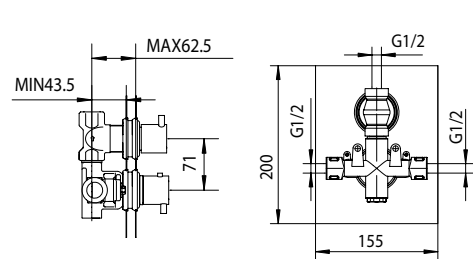

UNICO®, corpo per miscelatore termostatico da **1/2"** con **rubinetto da 1/2"** a dischi in ceramica a 180°.

UNICO®, body for 1/2" thermostatic mixer, concealed installation, with built-in 1/2" ceramic disc tap, 180°.

UNICO®, corps pour mitigeur thermostatique 1/2" à encaster, avec robinet 1/2" à disques en céramique, 180°.

UNICO®, Körper für Unterputz 1/2" Thermostat-Mischer mit 1/2" Keramische Scheiben Absperrventil 180°.

UNICO®, cuerpo de mezclador termostático 1/2" empotrable, con grifo 1/2" con discos de cerámica 180°.

l/m ¹	17	23	30	35	39
kg/cm ²	1	2	3	4	5

10 € 165,00

992771

[unico]



Solo parti esterne - Exposed parts only
Parties extérieures seule - Aufputzteile
Partes externas

10 € 80,00

UNICO®, corpo per miscelatore termostatico da **3/4"** con **rubinetto da 3/4"** a dischi in ceramica a 180°.

UNICO®, body for 3/4" thermostatic mixer, concealed installation, with built-in 3/4" ceramic disc tap, 180°.

UNICO®, corps pour mitigeur thermostatique 3/4" à encaster, avec robinet 3/4" à disques en céramique, 180°.

UNICO®, Körper für Unterputz 3/4" Thermostat-Mischer mit 3/4" Keramische Scheiben Absperrventil 180°.

UNICO®, cuerpo de mezclador termostático 3/4" empotrable, con grifo 3/4" con discos de cerámica 180°.

l/m	7	9,7	12	15	22	31	40
kg/cm ²	0,1	0,2	0,3	0,5	1	2	3

10 € 185,00

992772

[unico]



Solo parti esterne - Exposed parts only
Parties extérieures seule - Aufputzteile
Partes externas

10 € 80,00

UNICO®, corpo per miscelatore termostatico **1/2"** da incasso con deviatore a dischi in ceramica a **2 uscite** e funzione di stop.

UNICO®, body for 1/2" thermostatic mixer, concealed installation, with 2 outlets diverter, ceramic discs and stop function.

UNICO®, corps pour mitigeur thermostatique 1/2" inverseur à disques en céramique 2 sorties et avec fonction de stop.

UNICO®, Körper für Unterputz 1/2" Thermostat-Mischer mit Keramik 2-Wegeumsteller mit Stop-Position.

UNICO®, cuerpo de mezclador termostático 1/2" empotrable con desviador con discos de cerámica a 2 salidas con stop.

l/m ¹	17	23	30	35	39
kg/cm ²	1	2	3	4	5

10 € 205,00

992773

[unico]



Solo parti esterne - Exposed parts only
Parties extérieures seule - Aufputzteile
Partes externas

10 € 80,00

UNICO®, corpo per miscelatore termostatico **3/4"** da incasso con deviatore a dischi in ceramica a **2 uscite** e funzione di stop.

UNICO®, body for 3/4" thermostatic mixer, concealed installation, with 2 outlets diverter, ceramic discs and stop function.

UNICO®, corps pour mitigeur thermostatique 3/4" à encaster 3/4" avec inverseur à disques en céramique, 2 sorties et avec fonction de stop.

UNICO®, Körper für Unterputz 3/4" Thermostat-Mischer mit Keramik 2-Wegeumsteller mit Stop-Position.

UNICO®, cuerpo de mezclador termostático 3/4" empotrable con desviador con discos de cerámica a 2 salidas con stop.

l/m	7,8	10,7	13	15,9	22,7	32	39
kg/cm ²	0,1	0,2	0,3	0,5	1	2	3

10 € 280,00

992774

[unico]



Solo parti esterne - Exposed parts only
Parties extérieures seule - Aufputzteile
Partes externas

10 € 80,00

UNICO®, corpo per miscelatore termostatico **1/2"** da incasso con deviatore a dischi in ceramica a **3 uscite** e funzione di stop.

UNICO®, body for 1/2" thermostatic mixer, concealed installation, with 3 outlets diverter, ceramic discs and stop function.

UNICO®, corps pour mitigeur thermostatique 1/2" à encaster 1/2" avec inverseur à disques en céramique, 3 sorties et avec fonction de stop.

UNICO®, Körper für Unterputz 1/2" Thermostat-Mischer mit Keramik 3-Wegeumsteller mit Stop-Position.

UNICO®, cuerpo de mezclador termostático 1/2" empotrable con desviador con discos de cerámica a 3 salidas con stop.

l/m ¹	9	13	15,7	17,6	19,4
kg/cm ²	1	2	3	4	5

10 € 225,00

992775

[unico]



Solo parti esterne - Exposed parts only
Parties extérieures seule - Aufputzteile
Partes externas

10 € 80,00

UNICO®, corpo per miscelatore termostatico **3/4"** da incasso con deviatore a dischi in ceramica a **3 uscite** e funzione di stop.

UNICO®, body for 3/4" thermostatic mixer, concealed installation, with 3 outlets diverter, ceramic discs and stop function.

UNICO®, corps pour mitigeur thermostatique 3/4" à encaster 3/4" avec inverseur à disques en céramique, 3 sorties et avec fonction de stop.

UNICO®, Körper für Unterputz 3/4" Thermostat-Mischer mit Keramik 3-Wegeumsteller mit Stop-Position.

UNICO®, cuerpo de mezclador termostático 3/4" empotrable con desviador con discos de cerámica a 3 salidas con stop.

l/m	7,8	10,7	13	15,9	22,7	32	39
kg/cm ²	0,1	0,2	0,3	0,5	1	2	3

10 € 285,00

992776

[unico]



Solo parti esterne - Exposed parts only
Parties extérieures seule - Aufputzteile
Partes externas

10 € 80,00

962500



962501



962502



962503



962504



962505



digit 2

Miscelatore termostatico ad incasso da 1/2" con due rubinetti a dischi in ceramica 180°.
 Concealed thermostatic mixer 1/2" with two stop valves, ceramic discs 180°.
 Mitigeur thermostatique à encastrer 1/2", avec deux robinets à têtes en céramique 180°.
 Unterputz-Thermostatbatterie 1/2" mit zwei Ventile mit keramische Scheibe, 180°.
 Mezclador termostático empotrado 1/2", con 2 grifos con discos de cerámica 180°.

l/m ¹	17	23	30	35	39
kg/cm ²	1	2	3	4	5

10 € 369,00

Miscelatore termostatico ad incasso corpo ad ingombro ridotto con due rubinetti 3/4" a dischi in ceramica 90°.
 Concealed thermostatic mixer reduced space body with two stop valves, 3/4" ceramic discs 90°.

Mitigeur thermostatique à encastrer, corps à encombrement réduit, avec deux robinets à têtes en céramique 90°.
 Unterputz-Thermostat Batterie, Körper mit geringer Platz Bedarf, mit zwei 3/4" Ventile mit keramische Scheibe 90°.

Mezclador termostático empotrado cuerpo espacio reducido, con 2 grifos con discos de cerámica 3/4" 90°.

l/m	7	9,7	12	15	22	31	40
kg/cm ²	0,1	0,2	0,3	0,5	1	2	3

10 € 409,00

962417



962418

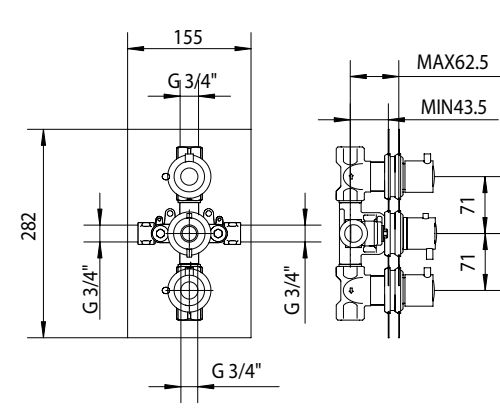
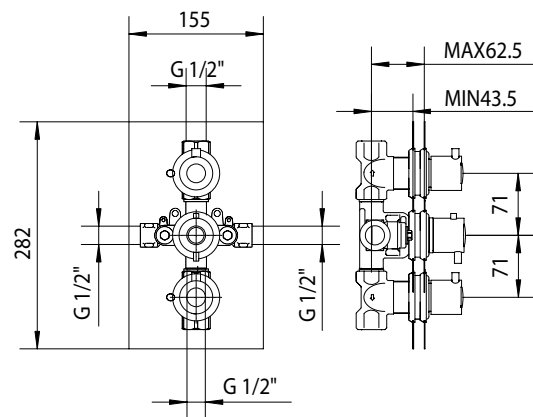

Miscelatore termostatico con asta doccia integrata, flessibile e doccetta.
 Thermostatic mixer, with built-in shower rail, flexible tube and handshower.
 Mitigeur thermostatique avec barre de douche intégrée, flexible et douchette.
 Thermostat Mischer mit eingebautem Duschestange, Brauseschlauch und Handbrause.
 Mezclador termostático con barra de ducha integrada, flexible y ducha de mano.

l/m ¹	6	12	16	20	24
kg/cm ²	0,5	1	2	3	4

10 € 295,00

Miscelatore termostatico con asta doccia integrata, flessibile e doccetta.
 Thermostatic mixer, with built-in shower rail, flexible tube and handshower.
 Mitigeur thermostatique avec barre de douche intégrée, flexible et douchette.
 Thermostat Mischer mit eingebautem Duschestange, Brauseschlauch und Handbrause.
 Mezclador termostático con barra de ducha integrada, flexible y ducha de mano.

l/m ¹	10	14	18	21	23
kg/cm ²	1	2	3	4	5

10 € 355,00

962044

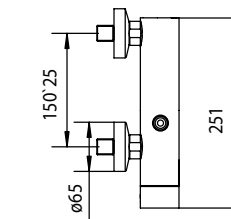
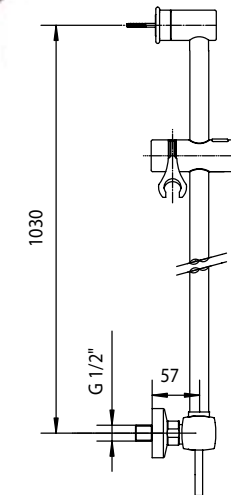
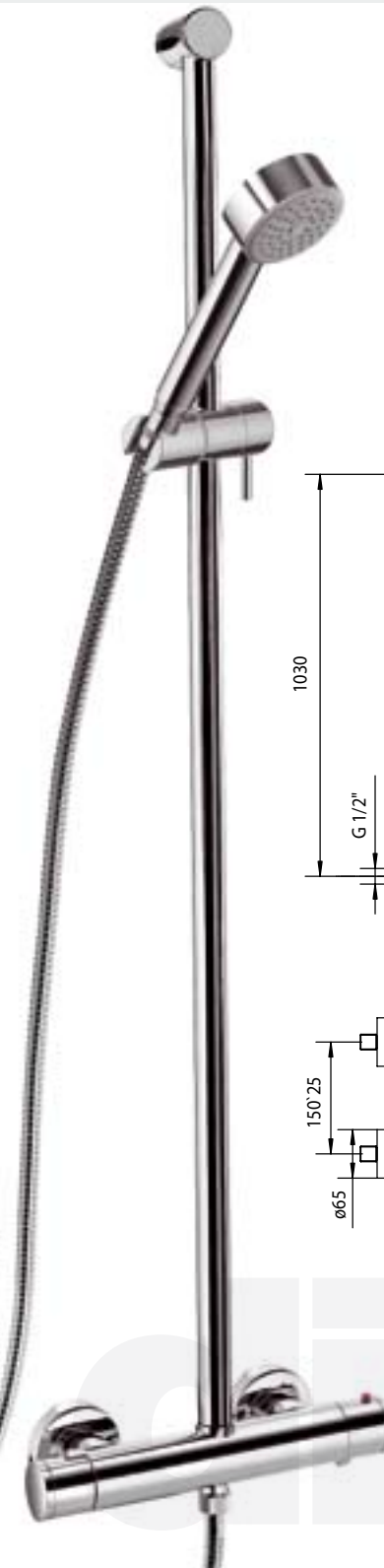

962046



digit 2

pin



finiture disponibili
available finishes
finition disponibles
verfügbare Farben
acabados disponibles

10 Cromo - Chrome
Chromé - Chrom

pin pin



Miscelatore monocomando per lavabo con scarico da 1" 1/4.
 Single control mixer for washbasin, with pop-up waste 1" 1/4.
 Mitigeur monocommande de lavabo, avec vidage 1" 1/4.
 Waschtisch Einhebelmischer mit Ablaufgarnitur 1" 1/4.
 Mezclador monomando para lavabo, con desagüe 1" 1/4.

Miscelatore monocomando per lavabo senza scarico.
 Single control mixer for washbasin, without waste.
 Mitigeur monocommande de lavabo, sans vidage.
 Waschtisch Einhebelmischer ohne Ablaufgarnitur.
 Mezclador monomando para lavabo, sin desagüe.

l/m	6	8	11	13	15
Kg/cm ²	0,5	1	2	3	4
10 € 94,00					

l/m	6	8	11	13	15
Kg/cm ²	0,5	1	2	3	4
10 € 84,00					

483010

483011

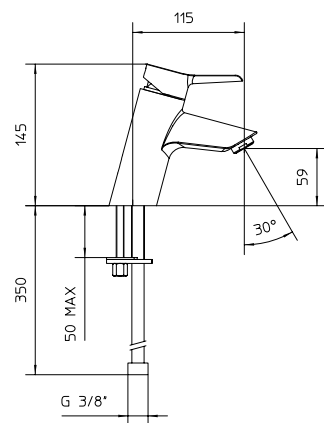
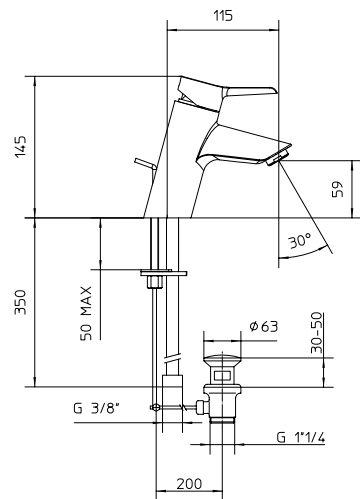

Miscelatore monocomando alto per lavabo con scarico 1" 1/4 Click-Clack.
 Tall single control mixer for washbasin, Click-Clack waste 1" 1/4.
 Mitigeur monocommande haut de lavabo, avec vidage Click-Clack 1" 1/4.
 Hoch Waschtisch Einhebelmischer mit Click-Clack Ablaufgarnitur 1" 1/4.
 Mezclador monomando alto para lavabo con desagüe Click-Clack 1" 1/4.

Miscelatore monocomando alto per lavabo senza scarico.
 Tall single control mixer for washbasin, without waste.
 Mitigeur monocommande haut de lavabo, sans vidage.
 Hoch Waschtisch Einhebelmischer ohne Ablaufgarnitur.
 Mezclador monomando alto para lavabo, sin desagüe.

l/m	6	8	11	13	15
Kg/cm ²	0,5	1	2	3	4
10 € 199,00					

l/m	6	8	11	13	15
Kg/cm ²	0,5	1	2	3	4
10 € 164,00					

483077

483018

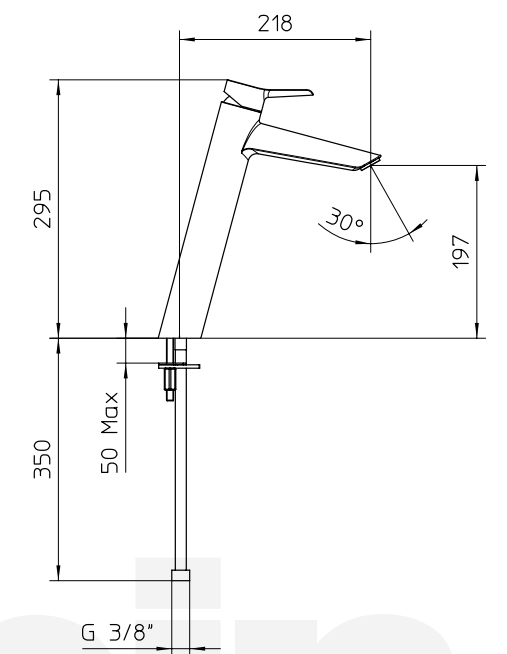
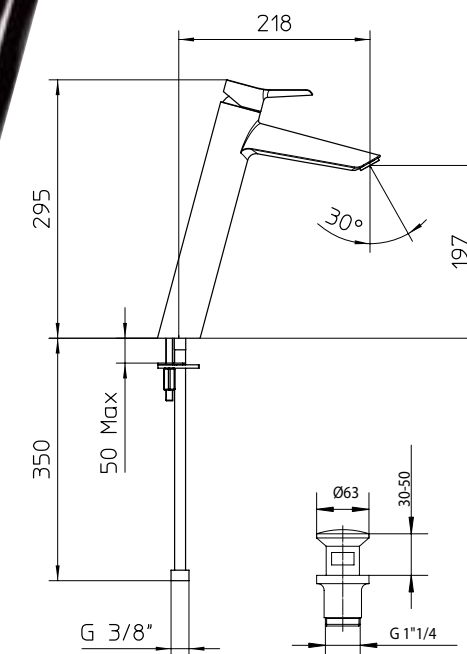
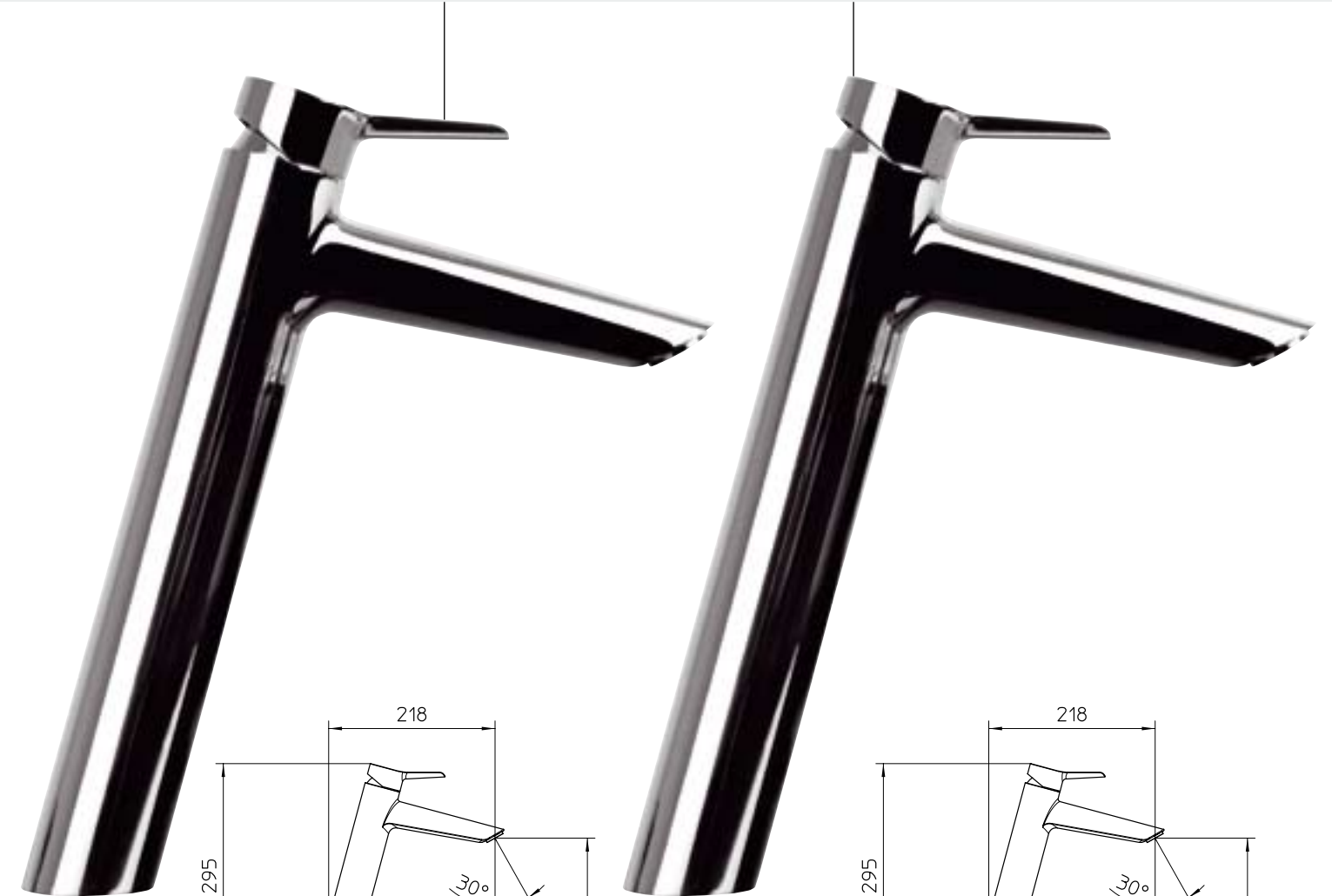

Miscelatore monocomando per bidet con scarico 1" 1/4.
 Single control mixer for bidet, with pop up waste 1" 1/4.
 Mitigeur monocommande de bidet, avec vidage 1" 1/4.
 Bidet Einhebelmischer mit Ablaufgarnitur 1" 1/4.
 Mezclador monomando para bidet con desagüe 1" 1/4.

Miscelatore monocomando per bidet senza scarico.
 Single control mixer for bidet, without waste.
 Mitigeur monocommande de bidet, sans vidage.
 Bidet Einhebelmischer ohne Ablaufgarnitur.
 Mezclador monomando para bidet sin desagüe.

l/m	6	8	11	13	15
Kg/cm ²	0,5	1	2	3	4
10 €	96,00				

l/m	6	8	11	13	15
Kg/cm ²	0,5	1	2	3	4
10 €	86,00				

484010

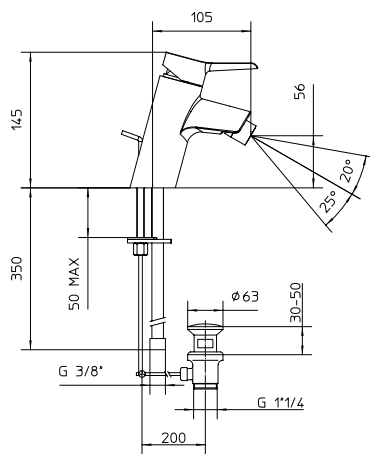

484011

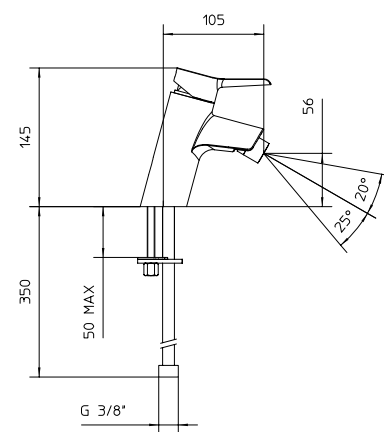

Miscelatore monocomando per vasca con deviatore, supporto doccia orientabile, flessibile 1,5 m e doccia.
 Wall mounted bath-shower mixer, with diverter, swivel bracket with flexible tube 1,5 m and handshower.
 Mitigeur monocommande de bain-douche, flexible 1,5 m, douchette et support mural orientable.
 Einhebelmischer als Wannenfüllbatterie mit verstellbarer Brausehalter, Handbrause, und Brauseschlauch 1,5 m.
 Mezclador monomando para bañera con desviador, soporte de ducha orientable, flexible 1,5 m y ducha de mano.

Miscelatore monocomando per vasca con deviatore, supporto doccia fisso, flessibile 1,5 m e doccia.
 Wall mounted bath-shower mixer, with diverter, fixed bracket with flexible tube 1,5 m and handshower.
 Mitigeur monocommande de bain-douche, flexible 1,5 m, douchette et support mural fixe.
 Einhebelmischer als Wannenfüllbatterie mit Brausehalter, Handbrause, und Brauseschlauch 1,5 m.
 Mezclador monomando para bañera con desviador, soporte de ducha fijo, flexible 1,5 m y ducha de mano.

l/m ¹	6	12	16	20	24
kg/cm ²	0,5	1	2	3	4
10 €	152,00				

l/m ¹	6	12	16	20	24
kg/cm ²	0,5	1	2	3	4
10 €	142,00				

481012

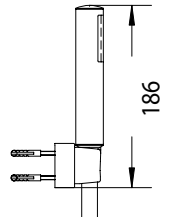
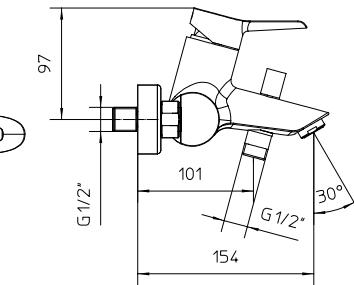
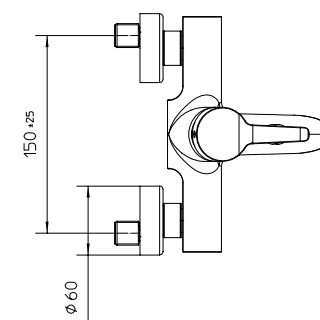
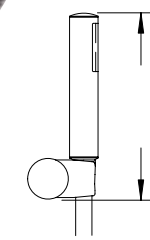

481010



pin



pin

Miscelatore monocomando per vasca con deviatore, supporto doccia orientabile, flessibile 1,5 m e doccia.

Wall mounted bath-shower mixer, with diverter, swivel bracket with flexible tube 1,5 m and handshower.

Mitigeur monocommande de bain-douche, flexible 1,5 m, douchette et support mural orientable.

Einhebelmischer als Wannenfüllbatterie mit verstellbarer Brausehalter, Handbrause, und Brauseschlauch 1,5 m.

Mezclador monomando para bañera con desviador, soporte de ducha orientable, flexible 1,5 m y ducha de mano.

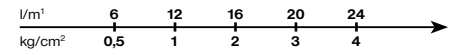

10 € 130,00

Miscelatore monocomando per vasca con deviatore, supporto doccia fisso, flessibile 1,5 m e doccia.

Wall mounted bath-shower mixer, with diverter, fixed bracket with flexible tube 1,5 m and handshower.

Mitigeur monocommande de bain-douche, flexible 1,5 m, douchette et support mural fixe.

Einhebelmischer als Wannenfüllbatterie mit Brausehalter, Handbrause, und Brauseschlauch 1,5 m.

Mezclador monomando para bañera con desviador, soporte de ducha fijo, flexible 1,5 m y ducha de mano.

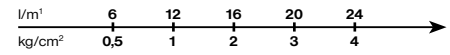

10 € 128,00

Miscelatore monocomando per vasca con deviatore, senza flessibile né doccia.

Wall mounted bath-shower mixer with diverter, without shower kit.

Mitigeur monocommande de bain-douche sans douchette ni flexible.

Einhebelmischer als Wannenfüllbatterie ohne Handbrause und ohne Brauseschlauch.

Mezclador monomando para bañera con desviador, sin flexible ni ducha de mano.

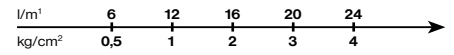

10 € 112,00

481013

481095

481015



Miscelatore monocomando per doccia, supporto orientabile, flessibile 1,5 m e doccia.

Wall mounted shower mixer, swivel bracket, flexible tube 1,5 m and handshower, .

Mitigeur monocommande de douche, avec douchette, flexible 1,5 m et support mural orientable.

Einhebelmischer als Brausebatterie mit verstellbarer Brausehalter, Handbrause, und Brauseschlauch 1,5 m.

Mezclador monomando para ducha, soporte de ducha orientable, flexible 1,5 m y ducha de mano.

Miscelatore monocomando per doccia, supporto orientabile, flessibile 1,5 m e doccia.

Wall mounted shower mixer, swivel bracket, flexible tube 1,5 m and handshower, .

Mitigeur monocommande de douche, avec douchette, flexible 1,5 m et support mural orientable.

Einhebelmischer als Brausebatterie mit verstellbarer Brausehalter, Handbrause, und Brauseschlauch 1,5 m.

Mezclador monomando para ducha, soporte de ducha orientable, flexible 1,5 m y ducha de mano.

Miscelatore monocomando per doccia, senza flessibile né doccia.

Wall mounted shower mixer, without shower kit.

Mitigeur monocommande de douche, sans douchette ni flexible.

Brause-Einhebelmischer, Aufputz, ohne Handbrause und ohne Brauseschlauch.

Mezclador monomando para ducha, sin flexible ni ducha de mano.

l/m¹ 7 10 14 18 21
kg/cm² 0,5 1 2 3 4

10 € 134,00

482020

l/m¹ 7 10 14 18 21
kg/cm² 0,5 1 2 3 4

10 € 112,00

482097

l/m¹ 7 10 14 18 21
kg/cm² 0,5 1 2 3 4

10 € 94,00

482015

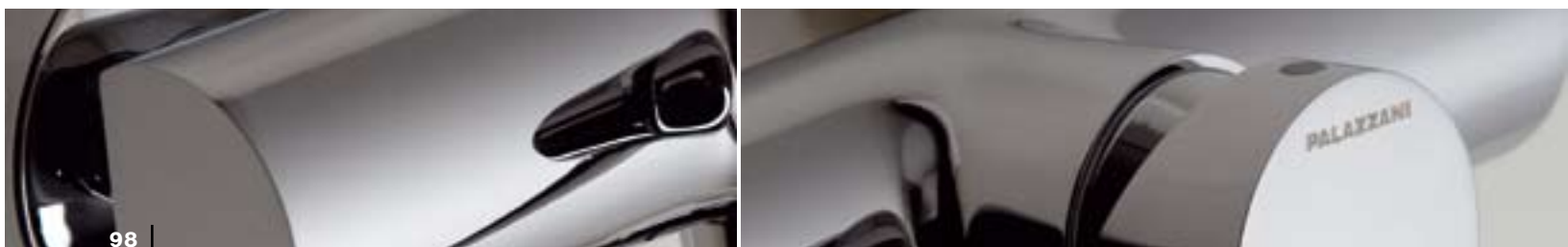
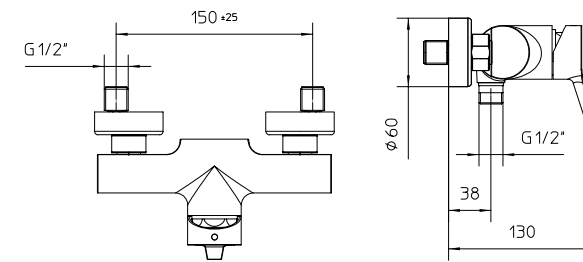

Miscelatore monocomando da incasso completo per vasca-doccia con deviatore automatico.

Complete concealed single lever mixer for bath shower with automatic diverter.

Mitigeur monocommande à encastrer complet pour bain-douche avec inverseur automatique.

Komplett Unterputz Wannenfäll und Brausebatterie mit Umsteller.

Mezclador monomando empotrable para baño-ducha completo con desviador automático.

UNICO®, corpo da incasso per miscelatore monocomando vasca-doccia con deviatore automatico, senza parti esterne.

UNICO®, concealed body for bath-shower with automatic diverter, without exposed parts.

UNICO®, corps de mitigeur monocommande à encastrer de bain-douche avec inverseur, sans parties extérieures.

UNICO®, Unterputz Körper für Wannenfäll und Brausebatterie mit Umsteller, ohne Aufputzteile.

UNICO®, cuerpo de mezclador monomando empotrable para baño-ducha con desviador automático, sin partes externas.

Solo parti esterne per miscelatore monocomando vasca-doccia con deviatore.

Exposed parts only for bath-shower concealed mixer with automatic diverter.

Parties extérieures seules pour mitigeur monocommande de bain-douche avec inverseur automatique.

Aufputzteile für Wannenfäll und Brausebatterie mit Umsteller.

Partes externas de mezclador monomando empotrable para baño-ducha con desviador automático.

Miscelatore monocomando da incasso completo per doccia.

Complete concealed single lever mixer for shower.

Mitigeur monocommande complet à encastrer pour douche.

Komplett Unterputz Brausebatterie.

Mezclador monomando empotrable completo para ducha.

UNICO®, corpo da incasso per miscelatore monocomando per doccia, senza parti esterne.

UNICO®, concealed body for shower, without exposed parts.

UNICO®, corps de mitigeur monocommande à encastrer pour douche, sans parties extérieures.

UNICO®, Unterputzkörper für Brausebatterie ohne Aufputzteile.

UNICO®, cuerpo de mezclador monomando empotrable para ducha, sin partes externas.

Solo parti esterne per miscelatore monocomando da incasso per doccia.

Exposed parts only for shower concealed mixer.

Parties extérieures seules pour mitigeur monocommande à encastrer pour douche.

Aufputzteile Teile für Unterputzbrausebatterie.

Sólo partes externas para mezclador monomando empotrable para ducha.

l/m	11	15	21	26	29
Kg/cm ²	0,5	1	2	3	4

10 € 135,00

l/m	11	15	21	26	29
Kg/cm ²	0,5	1	2	3	4

10 € 99,00

10 € 40,00

l/m	13	16	25	30	34
Kg/cm ²	0,5	1	2	3	4

10 € 65,00

l/m	13	16	25	30	34
Kg/cm ²	0,5	1	2	3	4

10 € 39,50

10 € 28,50

481022



992727



481027



482012



992726



482013



Miscelatore monocomando da incasso completo per doccia in POLIPROPILENE. POLIPROPYLENE concealed complete shower mixer.

Mitigeur monocommande à encastrer pour douche complet en POLIPROPILENE.

Unterputz Einhebelmischer komplett für Dusche aus POLIPROPILENE.

Mezclador monomando empotrable completo para ducha de POLIPROPILENE.

l/m	13	16	25	30	34
Kg/cm ²	0,5	1	2	3	4

10 € 65,00

UNICO®, POLIPROPILENE

10 € 39,50

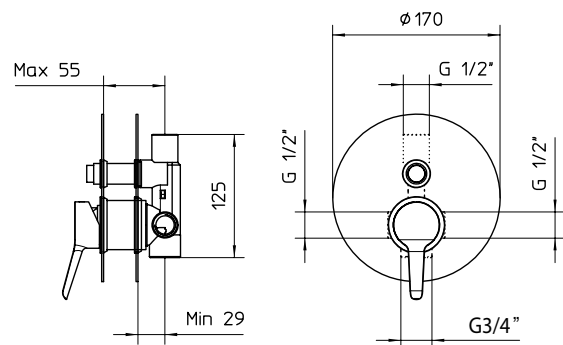
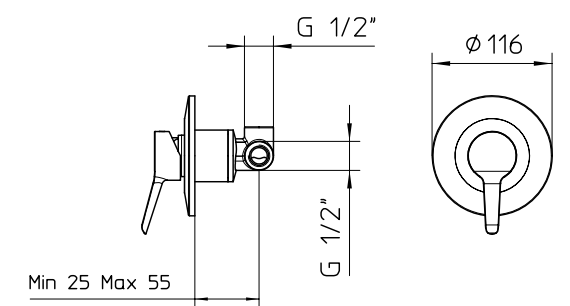

482912



992732

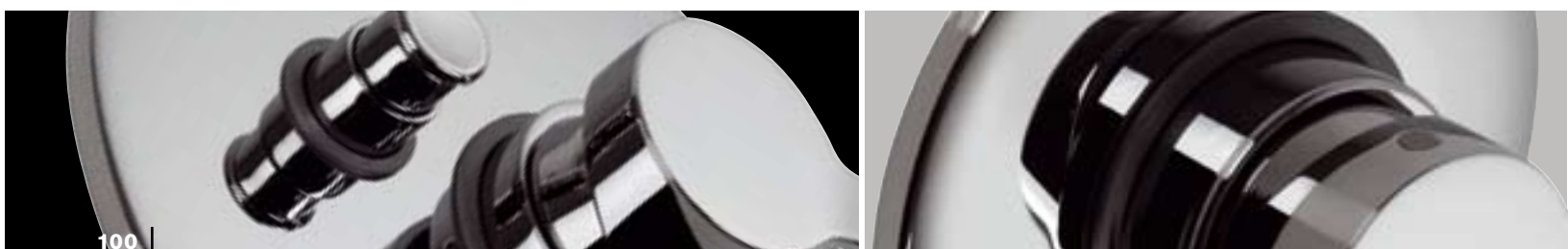

pin

flap



finiture disponibili
available finishes
finition disponibles
verfügbare Farben
acabados disponibles

10 Cromo - Chrome
Chromé - Chrom

Miscelatore monocomando per lavabo con scarico da 1" 1/4.
 Single control mixer for washbasin, with pop-up waste 1" 1/4.
 Mitigeur monocommande de lavabo, avec vidage 1" 1/4.
 Waschtisch Einhebelmischer mit Ablaufgarnitur 1" 1/4.
 Mezclador monomando para lavabo, con desagüe 1" 1/4.

Miscelatore monocomando per bidet con scarico 1" 1/4.
 Single control mixer for bidet, with pop up waste 1" 1/4.
 Mitigeur monocommande de bidet, avec vidage 1" 1/4.
 Bidet Einhebelmischer mit Ablaufgarnitur 1" 1/4.
 Mezclador monomando para bidet con desagüe 1" 1/4.

l/m	6	8	11	13	15
Kg/cm ²	0,5	1	2	3	4
10 €	78,50				

l/m	6	8	11	13	15
Kg/cm ²	0,5	1	2	3	4
10 €	79,50				

Miscelatore monocomando per vasca con deviatore, supporto doccia orientabile, flessibile 1,5 m e doccia.
 Wall mounted bath-shower mixer, with diverter, swivel bracket with flexible tube 1,5 m and handshower.
 Mitigeur monocommande de bain-douche, flexible 1,5 m, douchette et support mural orientable.
 Einhebelmischer als Wannenfüllbatterie mit verstellbarer Brausehalter, Handbrause, und Brauseschlauch 1,5 m.
 Mezclador monomando para bañera con desviador, soporte de ducha orientable, flexible 1,5 m y ducha de mano.

Miscelatore monocomando per vasca con deviatore, supporto doccia fisso, flessibile 1,5 m e doccia.
 Wall mounted bath-shower mixer, with diverter, fixed bracket with flexible tube 1,5 m and handshower.
 Mitigeur monocommande de bain-douche, flexible 1,5 m, douchette et support mural fixe.
 Einhebelmischer als Wannenfüllbatterie mit Brausehalter, Handbrause, und Brauseschlauch 1,5 m.
 Mezclador monomando para bañera con desviador, soporte de ducha fijo, flexible 1,5 m y ducha de mano.

Miscelatore monocomando per vasca con deviatore, senza flessibile né doccia.
 Wall mounted bath-shower mixer with diverter, without shower kit.
 Mitigeur monocommande de bain-douche sans douchette ni flexible.
 Einhebelmischer als Wannenfüllbatterie ohne Handbrause und ohne Brauseschlauch.
 Mezclador monomando para bañera con desviador, sin flexible ni ducha de mano.

l/m ¹	6	12	16	20	24
kg/cm ²	0,5	1	2	3	4
10 €	109,70				

l/m ¹	6	12	16	20	24
kg/cm ²	0,5	1	2	3	4
10 €	107,70				

l/m ¹	6	12	16	20	24
kg/cm ²	0,5	1	2	3	4
10 €	91,70				

473010

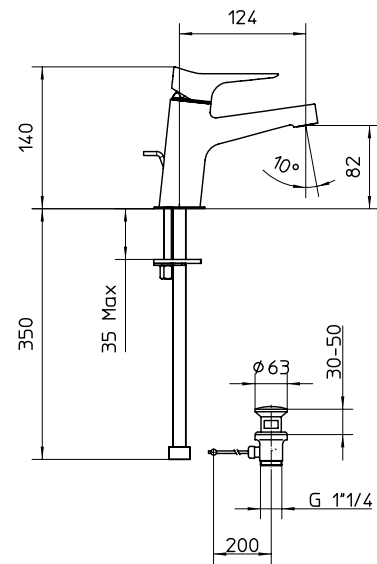

474010

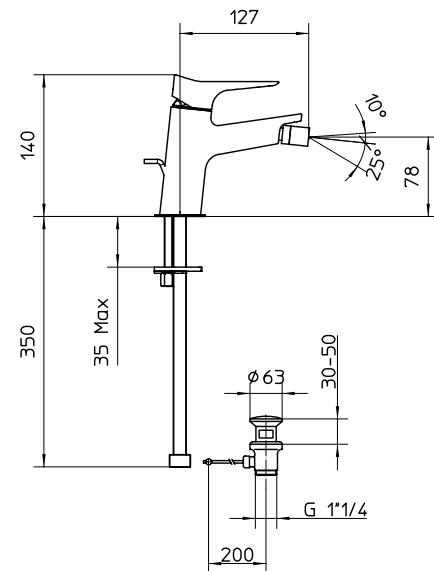

471012

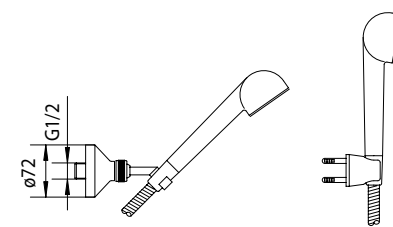

471010

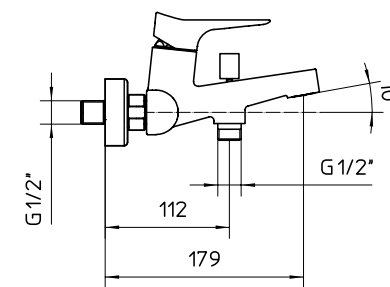

471015

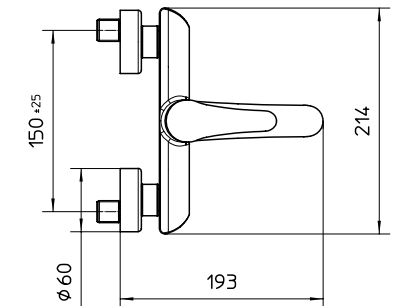

flap flap

Miscelatore monocomando per doccia, supporto orientabile, flessibile 1,5 m e doccia.

Wall mounted shower mixer, swivel bracket, flexible tube 1,5 m and handshower.

Mitigeur monocommande de douche, avec douchette, flexible 1,5 m et support mural orientable.

Einhebelmischer als Brausebatterie mit verstellbarer Brausehalter, Handbrause, und Brauseschlauch 1,5 m.

Mezclador monomando para ducha, soporte de ducha orientable, flexible 1,5 m y ducha de mano.

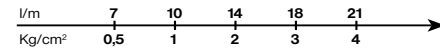

10 € 101,80

Miscelatore monocomando per doccia, senza flessibile né doccia.

Wall mounted shower mixer, without shower kit.

Mitigeur monocommande de douche, sans douchette ni flexible.

Brause-Einhebelmischer, Aufputz ohne Handbrause und ohne Brauseschlauch.

Mezclador monomando para ducha, sin flexible ni ducha de mano.

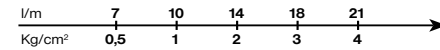

10 € 83,80

472020

472015

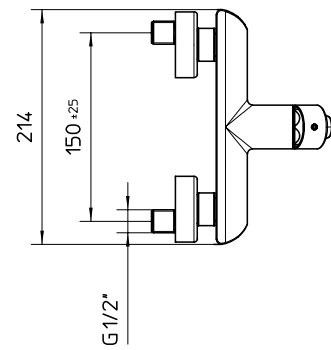
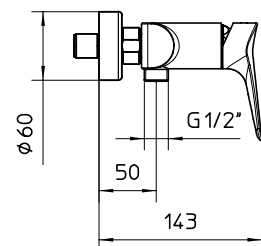
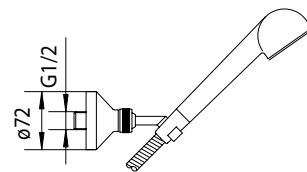

Miscelatore monocomando da incasso completo per vasca-doccia con deviatore automatico.

Complete concealed single lever mixer for bath shower with automatic diverter.

Mitigeur monocommande à encastrer complet pour bain-douche avec inverseur automatique.

Komplett Unterputz Wannenfüll und Brausebatterie mit Umsteller.

Mezclador monomando empotrable completo para baño-ducha con desviador automático.

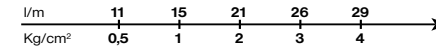

10 € 127,90

Miscelatore monocomando da incasso completo per doccia.

Complete concealed single lever mixer for shower.

Mitigeur monocommande complet à encastrer pour douche.

Komplett Unterputz Brausebatterie.

Mezclador monomando empotrable completo para ducha.

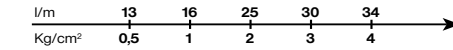

10 € 57,90

471020

472010

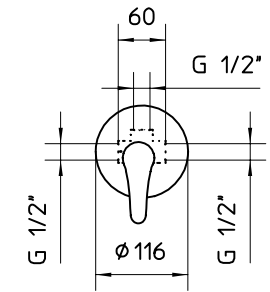
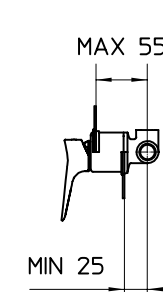
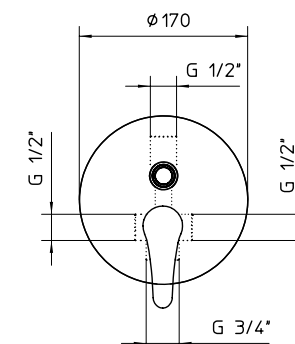
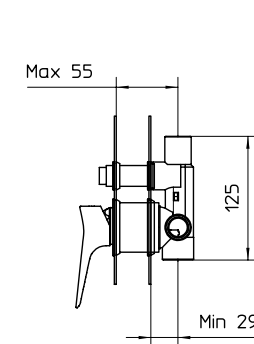

elettronico e temporizzato

rubinetto

elettronico e temporizzato

finiture disponibili
available finishes
finition disponibles
verfügbare Farben
acabados disponibles

10 Cromo - Chrome
Chromé - Chrom



normative

Conformità

I nostri rubinetti meccanici a chiusura automatica temporizzata sono conformi alla norma UNI EN 816 "Rubinetteria sanitaria - Rubinetteria a chiusura automatica PN10"; i nostri rubinetti elettronici sono conformi alla norma EN15091 "Sanitary tapware - Electronic opening and closing sanitary tapware".

Compatibilità Elettromagnetica **CE**

Si tratta di un'auto-certificazione nella quale il produttore deve garantire egli stesso la conformità dei suoi prodotti, e deve essere in grado di presentare su domanda delle autorità la prova di quello che certifica.

Tutti i prodotti elettrici o elettronici marchiati CE, attestano che sono conformi alle seguenti norme:

Compatibilità elettromagnetica: Direttiva 2004/108/CE

Direttiva Bassa Tensione: Direttiva 2006/95/CE

Inoltre:

- EN 50 082-1 Compatibilità elettromagnetica - Norma generica d'immunità - Ambiente domestico, commerciale e industriale leggero.
- EN 50 082-2 Compatibilità elettromagnetica - Norma generica d'immunità - Ambiente industriale, del 1998 e le emissioni di classe B EN 50, del 2001.
- EN 60947-5-1 Accessori elettrici a bassa tensione. Apparecchi ed elementi di commutazione per il controllo dei circuiti. Apparecchi elettromeccanici per circuiti di comando, giugno 2000 e IT 60947-5-1/A12, giugno 2000
- EN 60950-1 Sicurezza degli apparecchi di trasformazione, ivi comprese attrezzature elettriche per ufficio, aprile 2002. La norma descrive in dettaglio le prescrizioni di sicurezza previste per ridurre i rischi d'incendio, di scossa elettrica e lesioni per l'operatore o per i non addetti che possono venire a contatto con le apparecchiature. La norma ha lo scopo di ridurre tali rischi.

compliance

Compliance

Our time controlled, automatically shutting, mechanical tapware complies with the UNI EN 816 law, "Sanitary tapware - Automatically shutting tapware PN10", while our electronic tapware complies with the EN15091 law, "Sanitary tapware - Electronic opening and closing sanitary tapware".

Electromagnetic Compatibility **CE**

This is a self-certification in the measure of which the producer itself must guarantee the compliance of its products, and must be capable of presenting on demand of the authorities the proof of that which is certified.

All electric or electronic products marked CE, attest that they comply with the following legislation:

Electronic compatibility: CE Directive 2004/108/CE

Low Tension CE Directive 2006/95/CE

Furthermore:

- EN 50 082-1 Electromagnetic compatibility - Generic law of immunity - Domestic, commercial and light industry environment.
- EN 50 082-2 Electromagnetic compatibility - Generic law of immunity - Industrial environment, since 1998 and class B emissions EN 50, of 2001.
- EN 60947-5-1 Low power electric accessories. Appliances and electronic switching elements for circuit control. Electronic appliances for control circuits, June 2000 and IT 60947-5-1/A12, June 2000
- EN 60950-1 Safety of transformation appliances, including electric office equipment, April 2002. The law describes in detail the safety prescriptions to reduce risk of fire, electric shock and body harm to operators or unauthorised personnel who can come into contact with the appliance. The law is to reduce such risks.



Miscelatore elettronico per lavabo, completo di comando a fotocellula elettronica, **regolazione manuale della temperatura**, con sistema antivandalo e rubinetti filtro, **senza scarico**.
 Electronically controlled mixer for washbasin, with **manual temperature setting**, anti-vandal system, complete with filtering angle valves, **without waste**.
 Mitigeur électronique de lavabo, complet de commande à cellule électronique, **reglage manuel de la température**, système anti-vandale, complet de robinets-filtre, **sans vidage**.
 Elektronische Mischer mit Photo-elektrische Zelle, **Mechanische Temperaturreglung**, anti Vandale System, komplett mit Filter-Eckventile, **ohne Ablaufgarnitur**.
 Mezclador electrónico para lavabo, completo de mando fotocélula electrónica y con **regulación manual de la temperatura**, con sistema antivandalo y con grifos filtros, **sin desagüe**.

Miscelatore con elettrovalvola bistabile (1 entrata acqua calda, 1 entrata acqua fredda), alimentazione 220V/115V AC-6V DC.

Mixer with bi-stable solenoid valve (1 entry cold water, 1 entry hot water), main 220/115V AC-6V DC.

Mitigeur avec electro-vanne bi-stable (1 entrée eau froide, 1 entrée eau chaude), alimentation 220V/115 AC-6VDC.

Mischbatterie mit Doppelbeständigkeit Magnetventil (1 Eingang Kalt und 1 Eingang Warmeswasser), 220V/115 AC-6V DC.

Mezclador con electroválvula bistable (1 entrada agua caliente, 1 entrada agua fría), alimentación 220V/115V AC-6V DC.

Miscelatore con elettrovalvola bistabile (1 entrata acqua calda, 1 entrata acqua fredda), alimentazione pila al Lithium 6V.

Mixer with bi-stable solenoid valve (1 entry cold water, 1 entry hot water), Lithium battery 6V.

Mitigeur avec electro-vanne bi-stable (1 entrée eau froide, 1 entrée eau chaude), alimentation par batterie Lythium 6V.

Mischbatterie mit Doppelbeständigkeit Magnetventil (1 Eingang Kalt und 1 Eingang Warmeswasser), Batterie Lythium 6V.

Mezclador con electroválvula bistable (1 entrada agua caliente, 1 entrada agua fría), alimentación batería Lithium 6V.

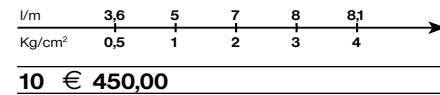
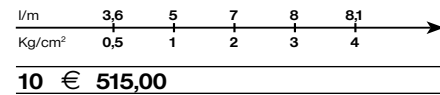

Miscelatore elettronico per lavabo, completo di comando a fotocellula elettronica, **regolazione manuale della temperatura** con sistema antivandalo e rubinetti filtro, **scarico Click-Clack**.
 Electronically controlled mixer for washbasin, with **manual temperature setting**, anti-vandal system, complete with filtering angle valves, **with Click-Clack waste**.
 Mitigeur électronique de lavabo, complet de commande à cellule électronique **reglage manuel de la température**, système anti-vandale, complet de robinets-filtre, **avec vidage Click-Clack**.
 Elektronische Mischer mit Photo-elektrische Zelle, **Mechanische Temperaturreglung**, anti Vandale System, komplett mit Filter-Eckventilemit, **Click-Clack Ablaufgarnitur**.
 Mezclador electrónico para lavabo, completo de mando fotocélula electrónica y con **regulación manual de la temperatura** con sistema antivandalo y con grifos filtros, con **desagüe automático Click-Clack**.

Miscelatore con elettrovalvola bistabile (1 entrata acqua calda, 1 entrata acqua fredda), alimentazione 220V/115V AC-6V DC.

Mixer with bi-stable solenoid valve (1 entry cold water, 1 entry hot water), main 220/115V AC-6V DC.

Mitigeur avec electro-vanne bi-stable (1 entrée eau froide, 1 entrée eau chaude), alimentation 220V/115 AC-6VDC.

Mischbatterie mit Doppelbeständigkeit Magnetventil (1 Eingang Kalt und 1 Eingang Warmeswasser), 220V/115 AC-6V DC.

Mezclador con electroválvula bistable (1 entrada agua caliente, 1 entrada agua fría), alimentación 220V/115V AC-6V DC.

Miscelatore con elettrovalvola bistabile (1 entrata acqua calda, 1 entrata acqua fredda), alimentazione pila al Lithium 6V.

Mixer with bi-stable solenoid valve (1 entry cold water, 1 entry hot water), Lithium battery 6V.

Mitigeur avec electro-vanne bi-stable (1 entrée eau froide, 1 entrée eau chaude), alimentation par batterie Lythium 6V.

Mischbatterie mit Doppelbeständigkeit Magnetventil (1 Eingang Kalt und 1 Eingang Warmeswasser), Batterie Lythium 6V.

Mezclador con electroválvula bistable (1 entrada agua caliente, 1 entrada agua fría), alimentación batería Lithium 6V.

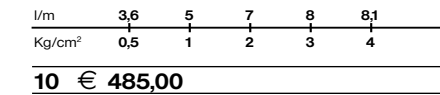
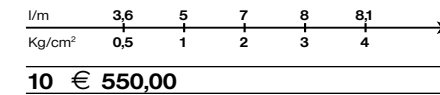

37E541

37E542

37E543

37E544

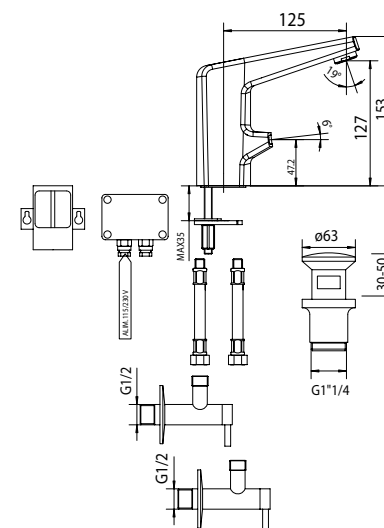
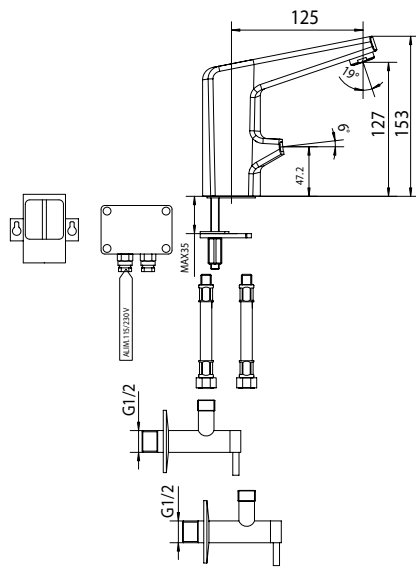

Risparmio acqua 50%, per case private - Water saving 50%, for private homes

electronico

Rubinetto elettronico per lavabo, completo di comando a fotocellula elettronica con sistema antivandalo e rubinetti filtro, **senza scarico**.
 Electronically controlled mixer for washbasin, **without waste**, anti-vandal system, complete with filtering angle valves.
 Robinet électronique de lavabo, complet de commande à cellule électronique système anti-vandale, complet de robinet filtre, **sans vidage**.
 Elektronische Mischer mit Photo-elektrische Zelle, anti Vandale System, komplett mit Filter-Eckventile, **ohne Ablaufgaritur**.
 Grifo electrónico para lavabo, completo de mando fotocélula electrónica con sistema antivándalo y con grifos filtros, **sin desagüe**.

Rubinetto elettronico per lavabo, completo di comando a fotocellula elettronica con sistema antivandalo e rubinetti filtro, **senza scarico**.
 Electronically controlled mixer for washbasin, **without waste**, anti-vandal system, complete with filtering angle valves.
 Robinet électronique de lavabo, complet de commande à cellule électronique système anti-vandale, complet de robinet filtre, **sans vidage**.
 Elektronische Mischer mit Photo-elektrische Zelle, anti Vandale System, komplett mit Filter-Eckventile, **ohne Ablaufgaritur**.
 Grifo electrónico para lavabo, completo de mando fotocélula electrónica con sistema antivándalo y con grifos filtros, **sin desagüe**.

Rubinetto **premiscelato** con elettrovalvola bistabile (1 entrata acqua calda, 1 entrata acqua fredda), alimentazione 220V/115V AC-6V DC.
Pre-mixing tap with bi-stable solenoid valve (1 entry cold water, 1 entry hot water), main 220/115V AC-6V DC.
Pre-melangeur avec electro-vanne bi-stable (1 entrée eau froide, 1 entrée eau chaude), alimentation 220V/115 AC-6V DC.
Vorgemischt mit Doppeltbeständigkeit Magnetventil (1 Eingang Kalt und 1 Eingang Warmes Wasser), 220V/115 AC-6V DC.
Premezclador con electroválvula bistable (1 entrada agua caliente, 1 entrada agua fría), alimentación 220V/115V AC-6V DC.

Rubinetto **premiscelato** con elettrovalvola bistabile (1 entrata acqua calda, 1 entrata acqua fredda), e pila al Lithium 6V.
Pre-mixing tap with bi-stable solenoid valve (1 entry cold water, 1 entry hot water), Lithium battery 6V.
Pre-melangeur avec electro-vanne bi-stable (1 entrée eau froide, 1 entrée eau chaude), alimentation par batterie Lythium 6V.
Vorgemischt mit Doppeltbeständigkeit Magnetventil (1 Eingang Kalt und 1 Eingang Warmes Wasser), Batterie Lythium 6V.
Premezclador con electroválvula bistable (1 entrada agua caliente, 1 entrada agua fría), batería Lithium 6V.

l/m	3,6	5	7	8	8,1
Kg/cm ²	0,5	1	2	3	4
10	€ 495,00				

l/m	3,6	5	7	8	8,1
Kg/cm ²	0,5	1	2	3	4
10	€ 430,00				

37E545

37E546

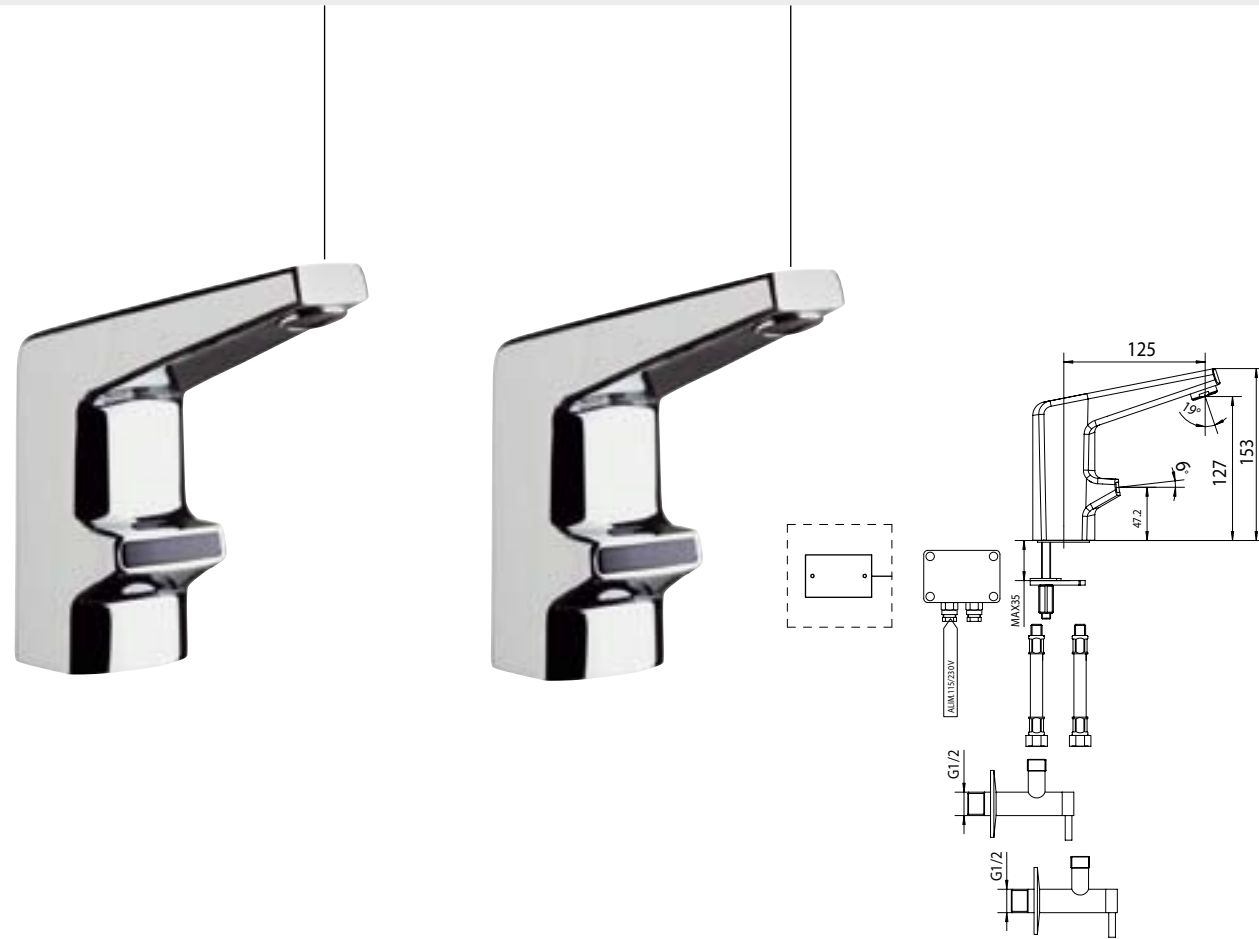

Rubinetto **monoacqua** con elettrovalvola bistabile (1 entrata acqua fredda o miscelata) e alimentazione 220-115V AC-6V DC.
Single water tap with bi-stable solenoid valve (1 entry cold or pre-mixed water), main 220/115V AC-6V DC.
Robinet mono avec electrovanne bi-stable (1 entrée eau froid ou pre-mitigée), alimentation 220V/115 AC-6V DC.
1 Wasserlauf mit Doppeltbeständigkeit Magnetventil (1 Eingang Kalt oder Misch Wasser), 220V/115 AC-6V DC.
Grifo monoagua con electroválvula bistable (1 entrada de agua fría o caliente), alimentación 220-115V AC-6V DC.

Rubinetto **monoacqua** con elettrovalvola bistabile (1 entrata acqua fredda o miscelata) e pila Lithium 6V.
Single water tap with bi-stable solenoid valve, (1 entry cold or pre-mixed water), Lithium battery 6V.
Robinet mono avec electrovanne bi-stable (1 entrée eau froid ou pre-mitigée), alimentation batterie Lythium 6V.
1 Wasserlauf mit Doppeltbeständigkeit Magnetventil (1 Eingang Kalt oder Misch Wasser), Batterie Lythium 6V.
Grifo monoagua con electroválvula bistable (1 entrada de agua fría o caliente), batería Lithium 6V.

l/m	3,6	5	7	8	8,1
Kg/cm ²	0,5	1	2	3	4
10	€ 475,00				

l/m	3,6	5	7	8	8,1
Kg/cm ²	0,5	1	2	3	4
10	€ 410,00				

37E547

37E548

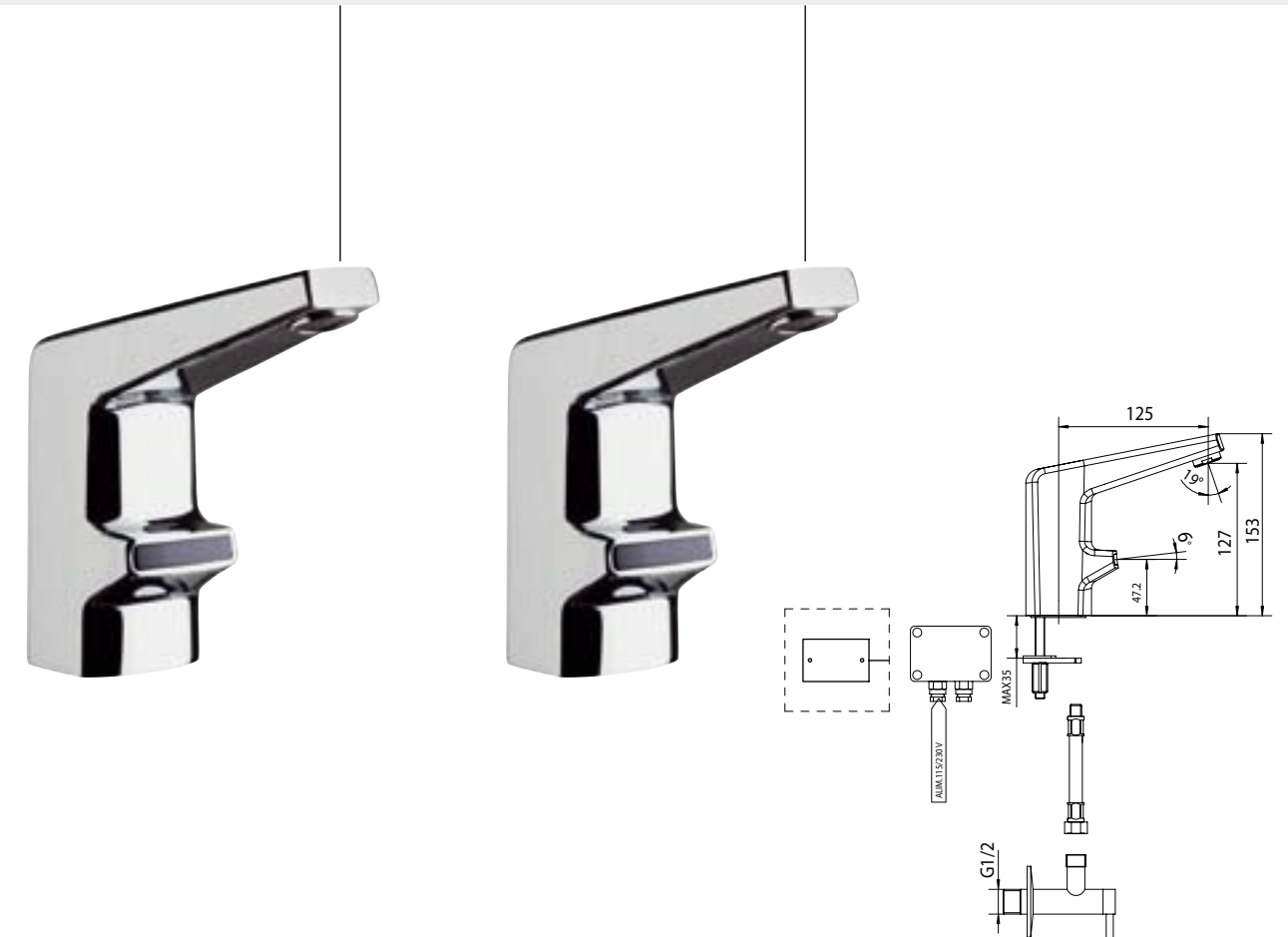

elettronici e temporizzati

elettronico gear

Rubinetto elettronico per lavabo, completo di comando a fotocellula elettronica con sistema antivandalo e rubinetti filtro, **senza scarico**.
 Electronically controlled mixer for washbasin, **without waste**, anti-vandal system, complete with filtering angle valves.
 Robinet électronique de lavabo, complet de commande à cellule électronique système anti-vandale, complet de robinet filtre, **sans vidage**.
 Elektronische Mischer mit Photo-elektrische Zelle, anti Vandale System, komplett mit Filter-Eckventile, **ohne Ablaufgaritur**.
 Grifo electrónico para lavabo, completo de mando fotocélula electrónica con sistema antivándalo y con grifos filtros, **sin desagüe**.

Rubinetto elettronico per lavabo, completo di comando a fotocellula elettronica con sistema antivandalo e rubinetti filtro, **senza scarico**.
 Electronically controlled mixer for washbasin, **without waste**, anti-vandal system, complete with filtering angle valves.
 Robinet électronique de lavabo, complet de commande à cellule électronique système anti-vandale, complet de robinet filtre, **sans vidage**.
 Elektronische Mischer mit Photo-elektrische Zelle, anti Vandale System, komplett mit Filter-Eckventile, **ohne Ablaufgaritur**.
 Grifo electrónico para lavabo, completo de mando fotocélula electrónica con sistema antivándalo y con grifos filtros, **sin desagüe**.

Rubinetto **premiscelato** con elettrovalvola bistabile (1 entrata acqua calda, 1 entrata acqua fredda), alimentazione 220V/115V AC-6V DC.
Pre-mixing tap with bi-stable solenoid valve (1 entry cold water, 1 entry hot water), main 220/115V AC-6V DC.
Pre-melangeur avec electro-vanne bi-stable (1 entrée eau froide, 1 entrée eau chaude), alimentation 220V/115 AC-6V DC.
Vorgemischt mit Doppeltbeständigkeit Magnetventil (1 Eingang Kalt und 1 Eingang Warmes Wasser), 220V/115 AC-6V DC.
Premezclador con electroválvula bistable (1 entrada agua caliente, 1 entrada agua fría), alimentación 220V/115V AC-6V DC.

Rubinetto **premiscelato** con elettrovalvola bistabile (1 entrata acqua calda, 1 entrata acqua fredda), e pila al Lithium 6V.
Pre-mixing tap with bi-stable solenoid valve (1 entry cold water, 1 entry hot water), Lithium battery 6V.
Pre-melangeur avec electro-vanne bi-stable (1 entrée eau froide, 1 entrée eau chaude), alimentation par batterie Lythium 6V.
Vorgemischt mit Doppeltbeständigkeit Magnetventil (1 Eingang Kalt und 1 Eingang Warmes Wasser), Batterie Lythium 6V.
Premezclador con electroválvula bistable (1 entrada agua caliente, 1 entrada agua fría), batería Lithium 6V.

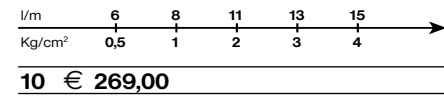
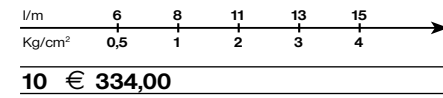

00E101

00E102

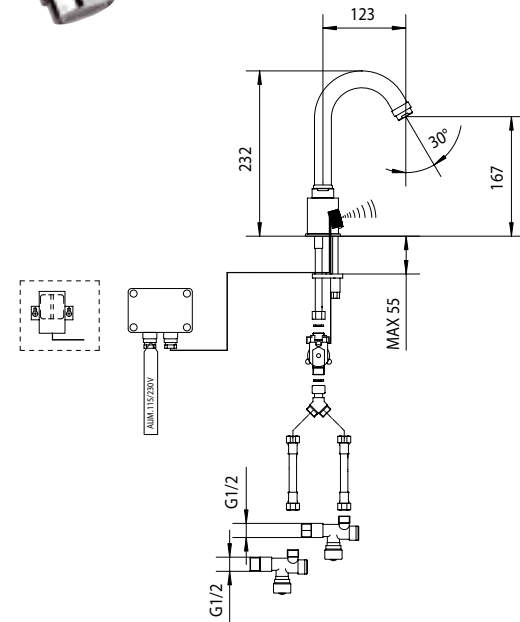

Rubinetto **monoacqua** con elettrovalvola bistabile (1 entrata acqua fredda o miscelata) e alimentazione 220-115V AC-6V DC.
Single water tap with bi-stable solenoid valve (1 entry cold or pre-mixed water), main 220/115V AC-6V DC.
Robinet mono avec electrovanne bi-stable (1 entrée eau froid ou pre-mitigée), alimentation 220V/115 AC-6V DC.
1 Wasserlauf mit Doppeltbeständigkeit Magnetventil (1 Eingang, Kalt oder Misch Wasser), 220V/115 AC-6V DC.
Grifo monoagua con electroválvula bistable (1 entrada de agua fría o caliente), alimentación 220-115V AC-6V DC.

Rubinetto **monoacqua** con elettrovalvola bistabile (1 entrata acqua fredda o miscelata) e pila Lithium 6V.
Single water tap with bi-stable solenoid valve, (1 entry cold or pre-mixed water), Lithium battery 6V.
Robinet mono avec electrovanne bi-stable (1 entrée eau froid ou pre-mitigée), alimentation batterie Lythium 6V.
1 Wasserlauf mit Doppeltbeständigkeit Magnetventil (1 Eingang, Kalt oder Misch Wasser), Batterie Lythium 6V.
Grifo monoagua con electroválvula bistable (1 entrada de agua fría o caliente), batería Lithium 6V.

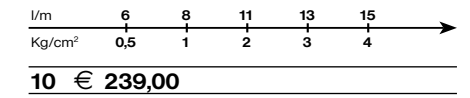
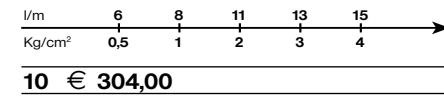

00E103

00E104

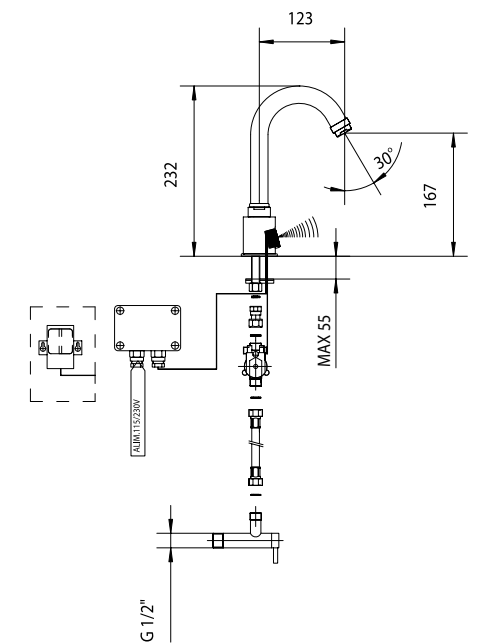

elettronici e temporizzati

digitale elettronico

Rubinetto monoforo per lavabo, funzionamento capacitivo (**no sensor**), dotato di sistema antivandalo e rubinetto filtro, **senza scarico**.
 Single opening faucet for washbasins, capacitive function (**no sensor**), equipped with anti-vandalism system and faucet filter, **without waste**.
 Robinet monotrou pour lavabo, fonctionnement capacitif (**sans capteur**), doté d'un système antivandalisme et d'un robinet filtre, **sans vidage**.
 1-Loch Wasserhahn armatur für Waschbecken, kapazitive Arbeitsweise (**kein Sensor**), zerstörungsfeste Ausstattung mit Hahnfilter, **ohne Ablaufgarnitur**.
 Grifo con 1 orificio para lavabo, funcionamiento capacitivo (**sin sensor**), dotado de sistema antivandalismo y grifo filtro, **sin desagüe**.

Rubinetto **premiscelato** con elettrovalvola bistabile (1 entrata acqua calda, 1 entrata acqua fredda), e pila al Lithium 6V.
Pre-mixing tap with bi-stable solenoid valve (1 entry cold water, 1 entry hot water), Lithium battery 6V.
Pre-melangeur avec electro-vanne bi-stable (1 entrée eau froide, 1 entrée eau chaude), alimentation par batterie Lithium 6V.
Vorgemischt mit Doppeltbeständigkeit Magnetventil (1 Eingang Kalt und 1 Eingang Warmes Wasser), Batterie Lithium 6V.
Premezclador con electroválvula bistable (1 entrada agua caliente, 1 entrada agua fría), batería Lithium 6V.

Rubinetto **monoacqua** con elettrovalvola bistabile (1 entrata acqua calda o miscelata) e pila Lithium 6V.
Single water tap with bi-stable solenoid valve, (1 entry cold or pre-mixed water), Lithium battery 6V.
Robinet mono avec electrovanne bi-stable (1 entrée eau froid ou pre-mitigée), alimentation batterie Lithium 6V.
1 Wasserlauf mit Doppeltbeständigkeit Magnetventil (1 Eingang, Kalt oder Misch Wasser), Batterie Lithium 6V.
Grifo monoagua con electroválvula bistable (1 entrada de agua fría o caliente), batería Lithium 6V.

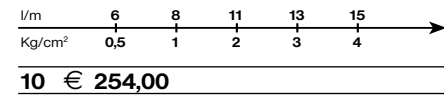
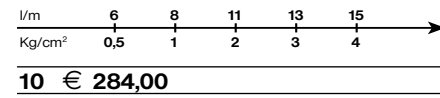

Miscelatore elettronico per lavabo, completo di comando a fotocellula elettronica, **regolazione manuale della temperatura**, con sistema antivandalo e rubinetti filtro, **senza scarico**.
 Electronically controlled mixer for washbasin, with **manual temperature setting**, anti-vandal system, complete with filtering angle valves, **without waste**.
 Mitigeur électronique de lavabo, complet de commande à cellule électronique, **reglage manuel de la température**, système anti-vandale, complet de robinets-filtre, **sans vidage**.
 Elektronische Mischer mit Photo-elektrische Zelle, **Mechanische Temperaturreglung**, anti Vandal System, komplett mit Filter-Eckventile, **ohne Ablaufgarnitur**.
 Mezclador electrónico para lavabo, completo de mando fotocélula electrónica y con **regulación manual de la temperatura**, con sistema antivandalo y grifos filtros, **sin desagüe**.

Miscelatore con due elettrovalvole bistabili (1 entrata acqua calda e 1 entrata acqua fredda) con alimentazione 230V/115V AC - 6V DC.
Mixer with two bistable solenoid valves (1 intake for hot water and 1 intake for cold water) with 230V/115V AC - 6V DC power supply.
Mélangeur avec deux électrovannes bistables (1 entrée eau chaude et 1 entrée eau froide) à alimentation 230V/115V AC - 6V DC.
Mischbatterie mit zwei Magnetventil (1 Warmwassereinlauf und 1 Kaltwassereinlauf) mit Stromversorgung 230V/115V AC - 6V DC.
Mezclador con dos electroválvulas biestable (1 entrada para el agua caliente y 1 entrada para el agua fría) con alimentación 230V/115V AC - 6V DC.

Miscelatore con due elettrovalvole bistabili (1 entrata acqua calda e 1 entrata acqua fredda) pila al Lithium 6V.
Mixer with two bistable solenoid valves (1 intake for hot water and 1 intake for cold water) Lithium battery 6V.
Mélangeur avec deux électrovannes bistables (1 entrée eau chaude et 1 entrée eau froide), alimentation par batterie Lithium 6V.
Mischbatterie mit zwei Magnetventil (1 Warmwassereinlauf und 1 Kaltwassereinlauf) Batterie Lithium 6V.
Mezclador con dos electroválvulas biestable (1 entrada para el agua caliente y 1 entrada para el agua fría), batería Lithium 6V.

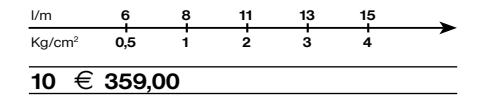
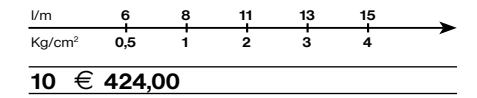

00S101

00S102

[no sensor]

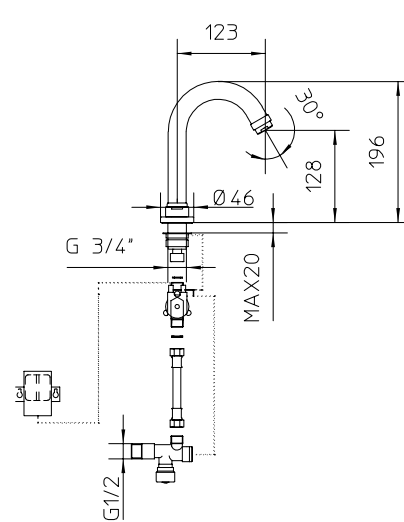
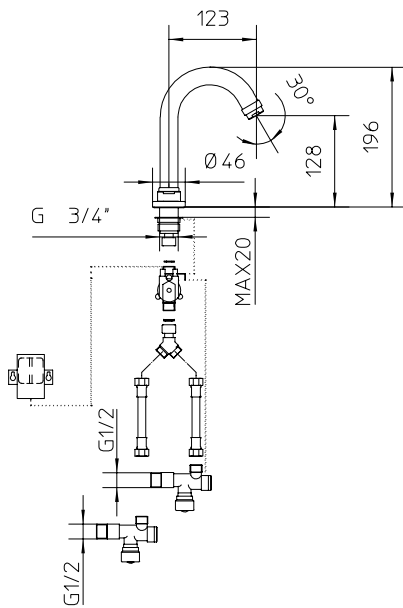

06E501

06E502

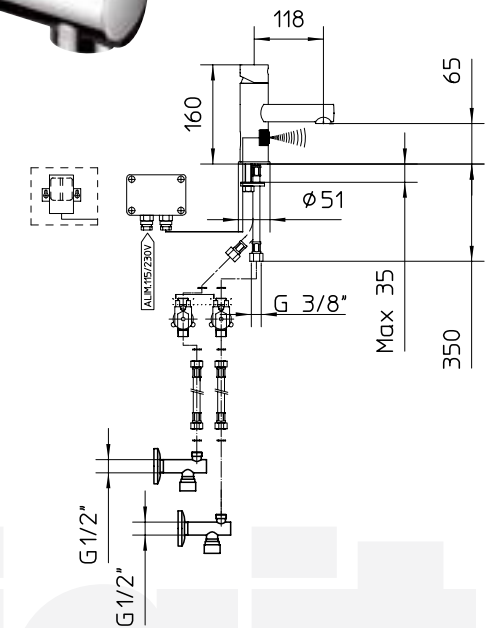

elettronici e temporizzati

elettronico

Rubinetto elettronico per lavabo, completo di comando a fotocellula elettronica con sistema antivandalo e rubinetti filtro, **senza scarico**.
 Electronically controlled mixer for washbasin, **without waste**, anti-vandal system, complete with filtering angle valves.
 Robinet électronique de lavabo, complet de commande à cellule électronique système anti-vandale, complet de robinet filtre, **sans vidage**.
 Elektronische Mischer mit Photo-elektrische Zelle, anti Vandale System, komplett mit Filter-Eckventile, **ohne Ablaufgarmitur**.
 Grifo electrónico para lavabo, completo de mando fotocélula electrónica con sistema antivándalo y con grifos filtros, **sin desagüe**.

Rubinetto elettronico per lavabo, completo di comando a fotocellula elettronica con sistema antivandalo e rubinetti filtro, **senza scarico**.
 Electronically controlled mixer for washbasin, **without waste**, anti-vandal system, complete with filtering angle valves.
 Robinet électronique de lavabo, complet de commande à cellule électronique système anti-vandale, complet de robinet filtre, **sans vidage**.
 Elektronische Mischer mit Photo-elektrische Zelle, anti Vandale System, komplett mit Filter-Eckventile, **ohne Ablaufgarmitur**.
 Grifo electrónico para lavabo, completo de mando fotocélula electrónica con sistema antivándalo y con grifos filtros, **sin desagüe**.

Rubinetto **premiscelato** con elettrovalvola bistabile (1 entrata acqua calda, 1 entrata acqua fredda), alimentazione 220V/115V AC-6V DC.
Pre-mixing tap with bi-stable solenoid valve (1 entry cold water, 1 entry hot water), main 220/115V AC-6V DC.
Pre-melangeur avec electro-vanne bi-stable (1 entrée eau froide, 1 entrée eau chaude), alimentation 220V/115 AC-6V DC.
Vorgemischt mit Doppeltbeständigkeit Magnetventil (1 Eingang Kalt und 1 Eingang Warmes Wasser), 220V/115 AC-6V DC.
Premezclador con electroválvula bistable (1 entrada agua caliente, 1 entrada agua fría), alimentación 220V/115V AC-6V DC.

Rubinetto **premiscelato** con elettrovalvola bistabile (1 entrata acqua calda, 1 entrata acqua fredda), e pila al Lithium 6V.
Pre-mixing tap with bi-stable solenoid valve (1 entry cold water, 1 entry hot water), Lithium battery 6V.
Pre-melangeur avec electro-vanne bi-stable (1 entrée eau froide, 1 entrée eau chaude), alimentation par batterie Lythium 6V.
Vorgemischt mit Doppeltbeständigkeit Magnetventil (1 Eingang Kalt und 1 Eingang Warmes Wasser), Batterie Lythium 6V.
Premezclador con electroválvula bistable (1 entrada agua caliente, 1 entrada agua fría), batería Lithium 6V.

l/m	6	8	11	13	15
Kg/cm ²	0,5	1	2	3	4
	→				
10	€ 380,00				

l/m	6	8	11	13	15
Kg/cm ²	0,5	1	2	3	4
	→				
10	€ 315,00				

06E505

06E506

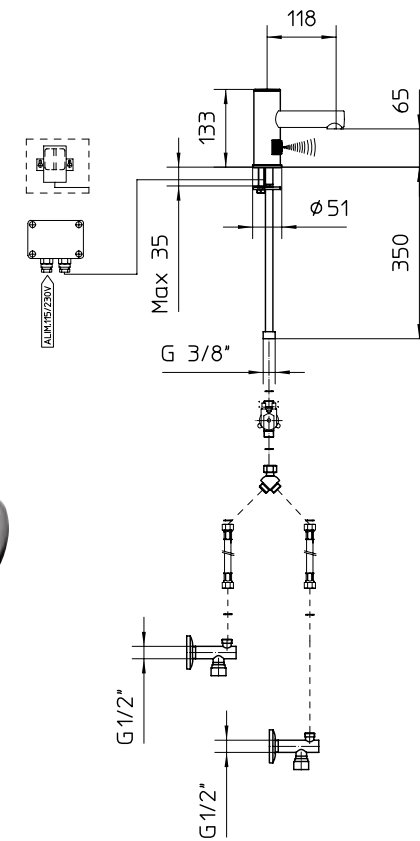

Rubinetto **monoacqua** con elettrovalvola bistabile (1 entrata acqua fredda o miscelata) e alimentazione 220-115V AC-6V DC.
Single water tap, with bi-stable solenoid valve (1 entry cold or pre-mixed water), main 220/115V AC-6V DC.
Robinet mono avec electrovanne bi-stable (1 entrée eau froid ou pre-mitigée), alimentation 220V/115 AC-6V DC.
1 Wasserlauf mit Doppeltbeständigkeit Magnetventil (1 Eingang, Kalt oder Misch Wasser), 220V/115 AC-6V DC.
Grifo monoagua con electroválvula bistable (1 entrada de agua fría o mezclada), alimentación 220-115V AC-6V DC.

Rubinetto **monoacqua** con elettrovalvola bistabile (1 entrata acqua fredda o miscelata) e pila Lithium 6V.
Single water tap with bi-stable solenoid valve, (1 entry cold or pre-mixed water), Lithium battery 6V.
Robinet mono avec electrovanne bi-stable (1 entrée eau froid ou pre-mitigée), alimentation batterie Lythium 6V.
1 Wasserlauf mit Doppeltbeständigkeit Magnetventil (1 Eingang, Kalt oder Misch Wasser), Batterie Lythium 6V.
Grifo monoagua con electroválvula bistable (1 entrada de agua fría o mezclada), batería Lithium 6V.

l/m	6	8	11	13	15
Kg/cm ²	0,5	1	2	3	4
	→				
10	€ 350,00				

l/m	6	8	11	13	15
Kg/cm ²	0,5	1	2	3	4
	→				
10	€ 285,00				

06E507

06E508

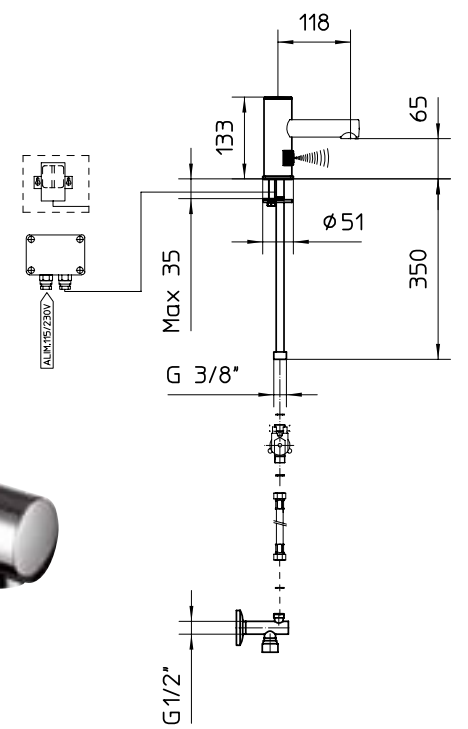

elettronici e temporizzati



elettronico digit

Miscelatore elettronico "midi" per lavabo, completo di comando a fotocellula elettronica, **regolazione manuale della temperatura**, con sistema antivandalo e rubinetti filtro, **senza scarico**.

Electronically controlled "midi" mixer for washbasin, with **manual temperature setting**, anti-vandal system, complete with filtering angle valves, **without waste**.

Mitigeur électronique "midi" de lavabo, complet de commande à cellule électronique, **reglage manuel de la température**, système anti-vandale, complet de robinets-filtre, **sans vidage**.

Elektronische Mischer "midi" mit Photo-elektrische Zelle, **Mechanische Temperaturreglung**, anti Vandale System, komplett mit Filter-Eckventile, **ohne Ablaufgarnitur**.

Mezclador electrónico "midi" para lavabo, completo de mando fotocélula electrónica y con **regulación manual de la temperatura**, con sistema antivandalo y grifos filtros, **sin desagüe**.

Miscelatore con due elettrovalvole bistabili (1 entrata acqua calda e 1 entrata acqua fredda) con alimentazione 230V/115V AC - 6V DC.

Mixer with two bistable solenoid valves (1 intake for hot water and 1 intake for cold water) with 230V/115V AC - 6V DC power supply.

Mélangeur avec deux électrovannes bistables (1 entrée eau chaude et 1 entrée eau froide) à alimentation 230V/115V AC - 6V DC.

Mischbatterie mit zwei Magnetventil (1 Warmwassereinlauf und 1 Kaltwassereinlauf) mit Stromversorgung 230V/115V AC - 6V DC.

Mezclador con dos electroválvulas biestable (1 entrada para el agua caliente y 1 entrada para el agua fría) con alimentación 230V/115V AC - 6V DC.

Miscelatore con due elettrovalvole bistabili (1 entrata acqua calda e 1 entrata acqua fredda) pila al Lithium 6V.

Mixer with two bistable solenoid valves (1 intake for hot water and 1 intake for cold water) Lithium battery 6V.

Mélangeur avec deux électrovannes bistables (1 entrée eau chaude et 1 entrée eau froide), alimentation par batterie Lythium 6V.

Mischbatterie mit zwei Magnetventil (1 Warmwassereinlauf und 1 Kaltwassereinlauf) Batterie Lythium 6V.

Mezclador con dos electroválvulas biestable (1 entrada para el agua caliente y 1 entrada para el agua fría), batería Lithium 6V.

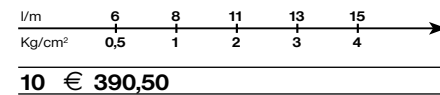
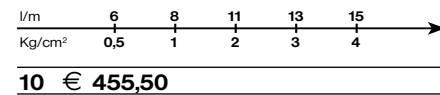

Rubinetto elettronico "midi" per lavabo, completo di comando a fotocellula elettronica con sistema antivandalo e rubinetti filtro, **senza scarico**.

Electronically controlled "midi" mixer for washbasin, **without waste**, anti-vandal system, complete with filtering angle valves.

Robinet électronique "midi" de lavabo, complet de commande à cellule électronique système anti-vandale, complet de robinet filtre, **sans vidage**.

Elektronische "midi" Mischer mit Photo-elektrische Zelle, anti Vandale System, komplett mit Filter-Eckventile, **ohne Ablaufgarnitur**.

Grifo electrónico "midi" para lavabo, completo de mando fotocélula electrónica con sistema antivandalo y con grifos filtros, **sin desagüe**.

Rubinetto **premiscelato** con elettrovalvola bistabile (1 entrata acqua calda, 1 entrata acqua fredda), alimentazione 220V/115V AC-6V DC.

Pre-mixing tap with bi-stable solenoid valve (1 entry cold water, 1 entry hot water), main 220/115V AC-6V DC.

Pre-mélangeur avec electro-vanne bi-stable (1 entrée eau froide, 1 entrée eau chaude), alimentation 220V/115 AC-6V DC.

Vorgemischt mit Doppeltbeständigkeit Magnetventil (1 Eingang Kalt und 1 Eingang Warmes Wasser), 220V/115 AC-6V DC.

Premezclador con electroválvula bistable (1 entrada agua caliente, 1 entrada agua fría), alimentación 220V/115V AC-6V DC.

Rubinetto **premiscelato** con elettrovalvola bistabile (1 entrata acqua calda, 1 entrata acqua fredda), e pila al Lithium 6V.

Pre-mixing tap with bi-stable solenoid valve (1 entry cold water, 1 entry hot water), Lithium battery 6V.

Pre-mélangeur avec electro-vanne bi-stable (1 entrée eau froide, 1 entrée eau chaude), alimentation par batterie Lythium 6V.

Vorgemischt mit Doppeltbeständigkeit Magnetventil (1 Eingang Kalt und 1 Eingang Warmes Wasser), Batterie Lythium 6V.

Premezclador con electroválvula bistable (1 entrada agua caliente, 1 entrada agua fría), batería Lithium 6V.

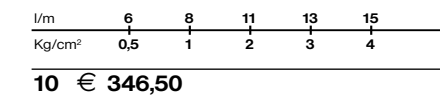
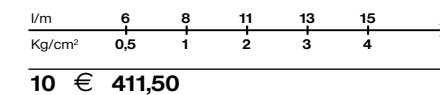

06E539

06E540

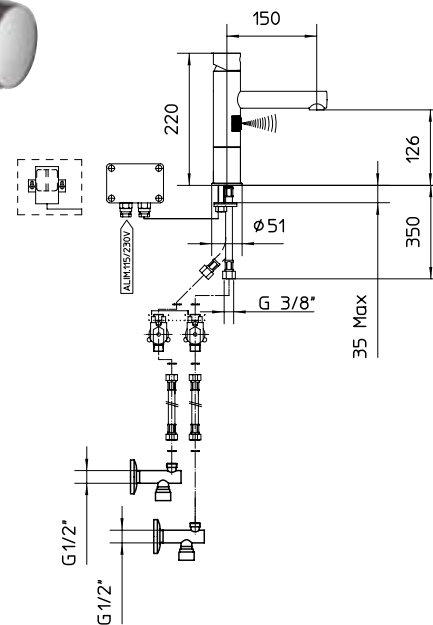

12E555

12E556

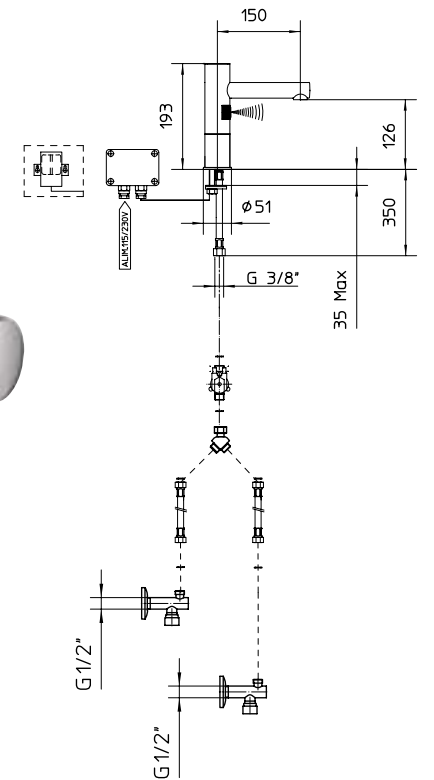

elettronici e temporizzati

digit elettronico

Rubinetto elettronico "midi" per lavabo, completo di comando a fotocellula elettronica con sistema antivandalo e rubinetti filtro, **senza scarico**.
 Electronically controlled "midi" mixer for washbasin, **without waste**, anti-vandal system, complete with filtering angle valves.
 Robinet électronique "midi" de lavabo, complet de commande à cellule électronique système anti-vandale, complet de robinet filtre, **sans vidage**.
 Elektronische "midi" Mischer mit Photo-elektrische Zelle, anti Vandale System, komplett mit Filter-Eckventile, **ohne Ablaufgarnitur**.
 Grifo electrónico "midi" para lavabo, completo de mando fotocélula electrónica con sistema antivándalo y con grifos filtros, **sin desagüe**.

Rubinetto **monoacqua** con elettrovalvola bistabile (1 entrata acqua fredda o miscelata) e alimentazione 220-115V AC-6V DC.

Single water tap, with bi-stable solenoid valve (1 entry cold or pre-mixed water), main 220/115V AC-6V DC.

Robinet mono, avec electrovanne bi-stable (1 entrée eau froid ou pre-mitigée), alimentation 220V/115 AC-6V DC.

1 Wasserlauf, mit Doppeltbeständigkeit Magnetventil (1 Eingang, Kalt oder Misch Wasser), 220V/115 AC-6V DC.

Grifo monoagua con electroválvula bistable (1 entrada de agua fría o mezclada), alimentación 220-115V AC-6V DC.

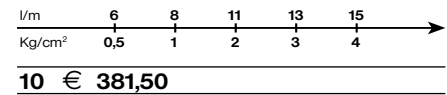

Rubinetto **monoacqua** con elettrovalvola bistabile (1 entrata acqua fredda o miscelata) e pila Lithium 6V.

Single water tap, with bi-stable solenoid valve, (1 entry cold or pre-mixed water), Lithium battery 6V.

Robinet mono, avec electrovanne bi-stable (1 entrée eau froid ou pre-mitigée), alimentation batterie Lythium 6V.

1 Wasserlauf, mit Doppeltbeständigkeit Magnetventil (1 Eingang, Kalt oder Misch Wasser), Batterie Lythium 6V.

Grifo monoagua con electroválvula bistable (1 entrada de agua fría o mezclada), batería Lithium 6V.

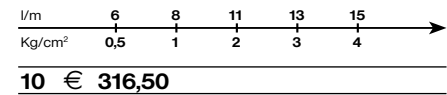

Miscelatore elettronico alto per lavabo, completo di comando a fotocellula elettronica, **regolazione manuale della temperatura**, con sistema antivandalo e rubinetti filtro, **senza scarico**.
 Electronically controlled tall mixer for washbasin, with **manual temperature setting**, anti-vandal system, complete with filtering angle valves, **without waste**.
 Mitigeur électronique haut de lavabo, complet de commande à cellule électronique, **reglage manuel de la température**, système anti-vandale, complet de robinets-filtre, **sans vidage**.
 Elektronische Hoch Mischer mit Photo-elektrische Zelle, **Mechanische Temperaturreglung**, anti Vandale System, komplett mit Filter-Eckventile, **ohne Ablaufgarnitur**.
 Mezclador electrónico alto para lavabo, completo de mando fotocélula electrónica y con **regulación manual de la temperatura**, con sistema antivándalo y grifos filtros, **sin desagüe**.

Miscelatore con due elettrovalvole bistabili (1 entrata acqua calda e 1 entrata acqua fredda) con alimentazione 230V/115V AC - 6V DC.

Mixer with two bistable solenoid valves (1 intake for hot water and 1 intake for cold water) with 230V/115V AC - 6V DC power supply.

Mélangeur avec deux électrovannes bistables (1 entrée eau chaude et 1 entrée eau froide) à alimentation 230V/115V AC - 6V DC.

Mischbatterie mit zwei Magnetventil (1 Warmwassereinlauf und 1 Kaltwassereinlauf) mit Stromversorgung 230V/115V AC - 6V DC.

Mezclador con dos electroválvulas biestable (1 entrada para el agua caliente y 1 entrada para el agua fría) con alimentación 230V/115V AC - 6V DC.

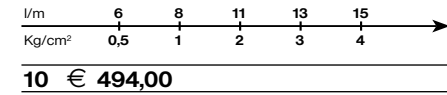

Miscelatore con due elettrovalvole bistabili (1 entrata acqua calda e 1 entrata acqua fredda) pila al Lithium 6V.

Mixer with two bistable solenoid valves (1 intake for hot water and 1 intake for cold water) Lithium battery 6V.

Mélangeur avec deux électrovannes bistables (1 entrée eau chaude et 1 entrée eau froide), alimentation par batterie Lythium 6V.

Mischbatterie mit zwei Magnetventil (1 Warmwassereinlauf und 1 Kaltwassereinlauf) Batterie Lythium 6V.

Mezclador con dos electroválvulas biestable (1 entrada para el agua caliente y 1 entrada para el agua fría), batería Lithium 6V.

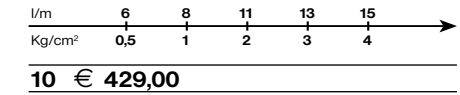

12E557

12E558



06E537

06E538



elettronico

elettronici e temporizzati

Rubinetto elettronico alto per lavabo, completo di comando a fotocellula elettronica con sistema antivandalo e rubinetti filtro, **senza scarico**.
 Electronically controlled tall mixer for washbasin, **without waste**, anti-vandal system, complete with filtering angle valves.
 Robinet électronique haut de lavabo, complet de commande à cellule électronique système anti-vandale, complet de robinet filtre, **sans vidage**.
 Elektronische Hoch Mischer mit Photo-elektrische Zelle, anti Vandale System, komplett mit Filter-Eckventile, **ohne Ablaufgarnitur**.
 Grifo electrónico alto para lavabo, completo de mando fotocélula electrónica con sistema antivándalo y con grifos filtros, **sin desagüe**.

Rubinetto elettronico alto per lavabo, completo di comando a fotocellula elettronica con sistema antivandalo e rubinetti filtro, **senza scarico**.
 Electronically controlled tall mixer for washbasin, **without waste**, anti-vandal system, complete with filtering angle valves.
 Robinet électronique haut de lavabo, complet de commande à cellule électronique système anti-vandale, complet de robinet filtre, **sans vidage**.
 Elektronische Hoch Mischer mit Photo-elektrische Zelle, anti Vandale System, komplett mit Filter-Eckventile, **ohne Ablaufgarnitur**.
 Grifo electrónico alto para lavabo, completo de mando fotocélula electrónica con sistema antivándalo y con grifos filtros, **sin desagüe**.

Rubinetto **premiscelato** con elettrovalvola bistabile (1 entrata acqua calda, 1 entrata acqua fredda), alimentazione 220V/115V AC-6V DC.
Pre-mixing tap with bi-stable solenoid valve (1 entry cold water, 1 entry hot water), main 220/115V AC-6V DC.
Pre-melangeur avec electro-vanne bi-stable (1 entrée eau froide, 1 entrée eau chaude), alimentation 220V/115 AC-6V DC.
Vorgemischt mit Doppeltbeständigkeit Magnetventil (1 Eingang Kalt und 1 Eingang Warmes Wasser), Batterie Lythium 6V.
Premezclador con electroválvula bistable (1 entrada agua caliente, 1 entrada agua fría), alimentación 220V/115V AC-6V DC.

Rubinetto **premiscelato** con elettrovalvola bistabile (1 entrata acqua calda, 1 entrata acqua fredda), e pila al Lithium 6V.
Pre-mixing tap with bi-stable solenoid valve (1 entry cold water, 1 entry hot water), Lithium battery 6V.
Pre-melangeur avec electro-vanne bi-stable (1 entrée eau froide, 1 entrée eau chaude), alimentation par batterie Lythium 6V.
Vorgemischt mit Doppeltbeständigkeit Magnetventil (1 Eingang Kalt und 1 Eingang Warmes Wasser), Batterie Lythium 6V.
Premezclador con electroválvula bistable (1 entrada agua caliente, 1 entrada agua fría), batería Lithium 6V.

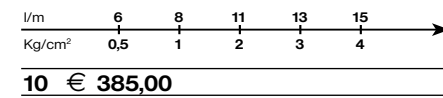
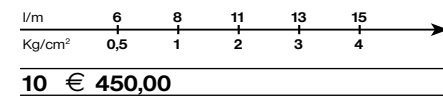

Rubinetto **monoacqua** con elettrovalvola bistabile (1 entrata acqua fredda o miscelata) e alimentazione 220-115V AC-6V DC.
Single water tap with bi-stable solenoid valve (1 entry cold or pre-mixed water), main 220/115V AC-6V DC.
Robinet mono avec electrovanne bi-stable (1 entrée eau froid ou pre-mitigée), alimentation 220V/115 AC-6V DC.
1 Wasserlauf mit Doppeltbeständigkeit Magnetventil (1 Eingang, Kalt oder Misch Wasser), 220V/115 AC-6V DC.
Grifo monoagua con electroválvula bistable (1 entrada de agua fría o mezclada), alimentación 220-115V AC-6V DC.

Rubinetto **monoacqua** con elettrovalvola bistabile (1 entrata acqua fredda o miscelata) e pila Lithium 6V.
Single water tap with bi-stable solenoid valve, (1 entry cold or pre-mixed water), Lithium battery 6V.
Robinet mono avec electrovanne bi-stable (1 entrée eau froid ou pre-mitigée), alimentation batterie Lythium 6V.
1 Wasserlauf mit Doppeltbeständigkeit Magnetventil (1 Eingang, Kalt oder Misch Wasser), Batterie Lythium 6V.
Grifo monoagua con electroválvula bistable (1 entrada de agua fría o mezclada), batería Lithium 6V.

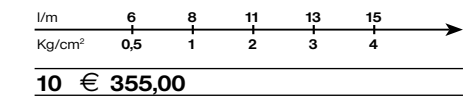
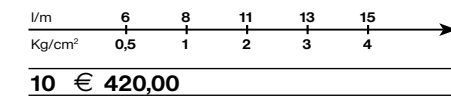

12E551

12E552

12E553

12E554

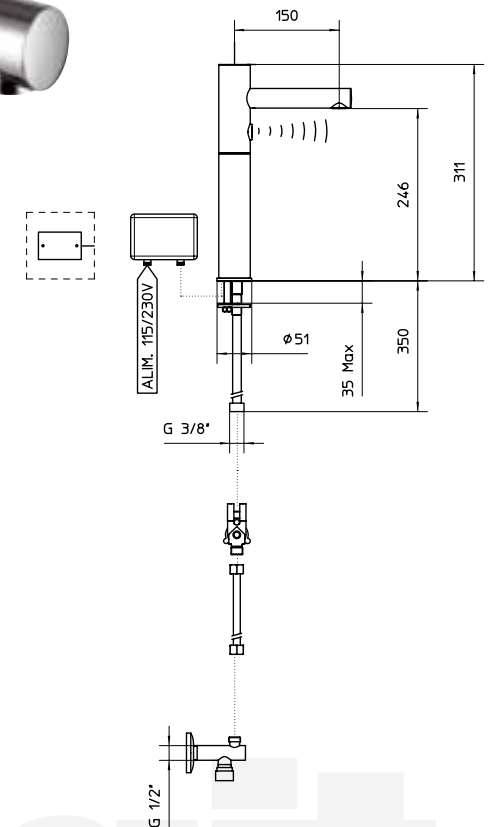
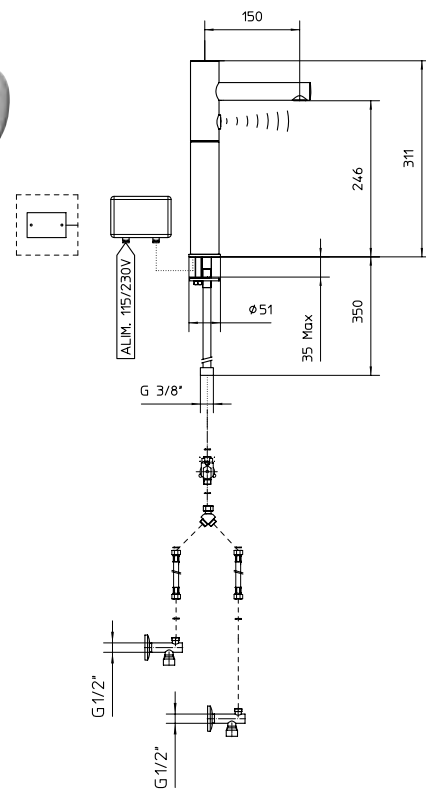

elettronici e temporizzati

digit
elettronico

Rubinetto elettronico da incasso per lavabo, completo di comando a fotocellula elettronica con sistema antivandalo.
 Concealed electronically controlled mixer for washbasin, anti-vandal system.
 Robinet électronique de lavabo à encastrer mural, complet de commande à cellule électronique et système anti-vandale.
 Elektronische Mischer mit Photo-elektrische Zelle, anti Vandale System.
 Grifo electrónico empotrable para lavabo, completo de mando fotocélula electrónica con sistema antivándalo.

Miscelatore con regolazione manuale della temperatura (1 entrata acqua calda e 1 entrata acqua fredda) pila al Lithium 6V.

Mixer with manual temperature setting (1 intake for hot water and 1 intake for cold water) Lithium battery 6V.

Mélangeur avec réglage manuel de la température (1 entrée eau chaude et 1 entrée eau froide), alimentation par batterie Lythium 6V.

Mischbatterie mit Mechanische Temperaturreglung (1 Warmwassereinlauf und 1 Kaltwassereinlauf) Batterie Lythium 6V.

Mezclador con regulación manual de la temperatura, (1 entrada para el agua caliente y 1 entrada para el agua fría), batería Lithium 6V.

Rubinetto **monoacqua** (1 entrata acqua fredda o miscelata), entrata laterale a 360° e pila Lithium 6V.

Single water tap (1 entry cold or pre-mixed water), side inlet at adjustable 360°, Lithium battery 6V.

Robinet mono (1 entrée eau froid ou pre-mittigée), entrée latérale 360°, alimentation batterie Lythium 6V.

1 Wasserlauf (1 Eingang, Kalt oder Misch Wasser), seitliche Eintrag 360°, Batterie Lythium 6V.

Grifo monoagua (1 entrada de agua fría o mezclada), entrada lateral 360°, batería Lithium 6V.

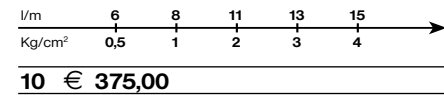
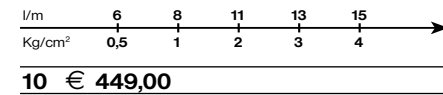

12E624

00E621

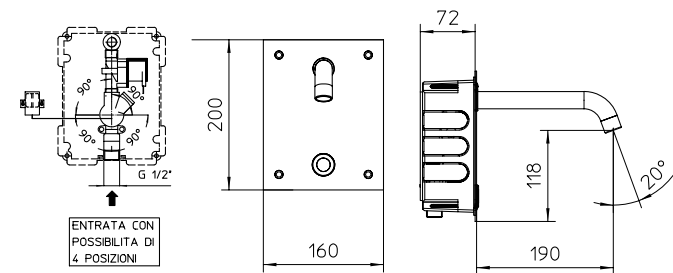
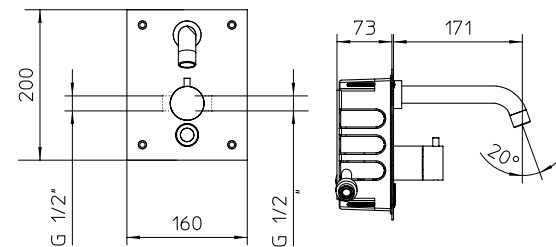

Rubinetto elettronico da incasso per doccia, completo di comando a fotocellula elettronica con sistema antivandalo.
 Concealed electronically controlled mixer for shower, anti-vandal system.
 Robinet électronique de douche à encastrer mural, complet de commande à cellule électronique et système anti-vandale.
 Elektronische Mischer für Dusche mit Photo-elektrische Zelle, anti Vandale System.
 Grifo electrónico empotrable para ducha, completo de mando fotocélula electrónica con sistema antivándalo.

Miscelatore con regolazione manuale della temperatura (1 entrata acqua calda e 1 entrata acqua fredda) pila al Lithium 6V.

Mixer with manual temperature setting (1 intake for hot water and 1 intake for cold water) Lithium battery 6V.

Mélangeur avec réglage manuel de la température (1 entrée eau chaude et 1 entrée eau froide), alimentation par batterie Lythium 6V.

Mischbatterie mit Mechanische Temperaturreglung (1 Warmwassereinlauf und 1 Kaltwassereinlauf) Batterie Lythium 6V.

Mezclador con regulación manual de la temperatura, (1 entrada para el agua caliente y 1 entrada para el agua fría), batería Lithium 6V.

Rubinetto **monoacqua** (1 entrata acqua fredda o miscelata), entrata laterale a 360° e pila Lithium 6V.

Single water tap (1 entry cold or pre-mixed water), side inlet at adjustable 360°, Lithium battery 6V.

Robinet mono (1 entrée eau froid ou pre-mittigée), entrée latérale 360°, alimentation batterie Lythium 6V.

1 Wasserlauf (1 Eingang, Kalt oder Misch Wasser), seitliche Eintrag 360°, Batterie Lythium 6V.

Grifo monoagua (1 entrada de agua fría o mezclada), entrada lateral 360°, batería Lithium 6V.

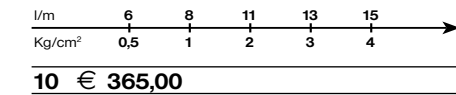
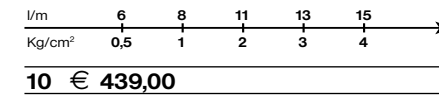

12E627

00E629

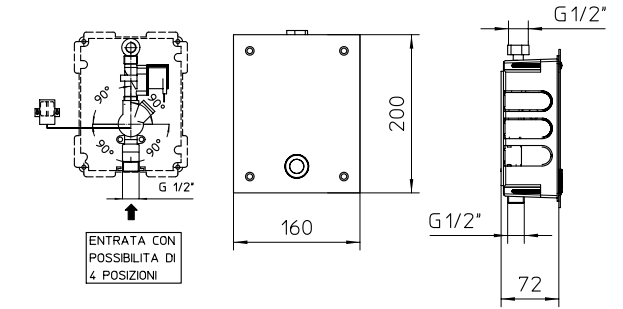
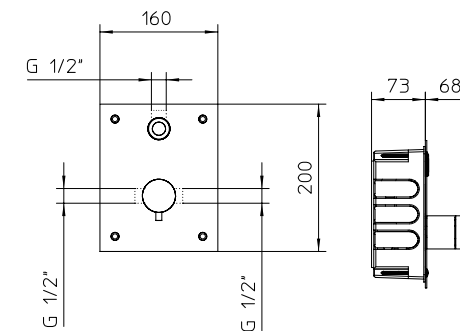

elettronici e temporizzati

elettronico digit

Miscelatore per lavabo con comando a pressione a chiusura automatica temporizzata, sistema di sicurezza antibloccaggio, regolazione manuale della temperatura, temporizzazione 15" impostata in fabbrica, senza scarico.

Washbasin timed **mixer** tap with pressure-controlled automatic closing timer, anti-blocking safety system, manual temperature regulator, factory time setting at 15", without waste.

Mitigeur à fermeture automatique temporisé pour lavabo, système de sécurité antiblocage, réglage manuel de la température, temporisation de 15" réglé en usine, sans vidage.

Zeitgesteuerte **Armatur** mit Antiblockier-Sicherheitssystem, Werkseinstellung der Zeitsteuerung: 15", ohne Ablaufgarnitur.

Mezclador temporizado para lavabo, sistema de seguridad antibloqueo, regulación manual de la temperatura, temporización de 15" configurada de fábrica sin desagüe.

Miscelatore per lavabo con comando a pressione a chiusura automatica temporizzata, regolazione manuale della temperatura, temporizzazione 15" impostata in fabbrica, senza scarico.

Washbasin timed **mixer** tap with pressure-controlled automatic closing timer, manual temperature regulator, factory time setting at 15", without waste.

Mitigeur à fermeture automatique temporisé pour lavabo, réglage manuel de la température, temporisation de 15" réglée en usine, sans vidage.

Selbstschluss **Armatur**, Laufzeit 15" Werkseitig eingestellt ohne Ablaufgarnitur.

Mezclador temporizado para lavabo, regulación manual de la temperatura, temporización de 15" configurada de fábrica sin desagüe.

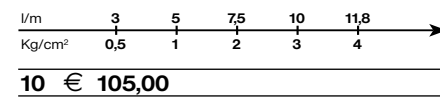
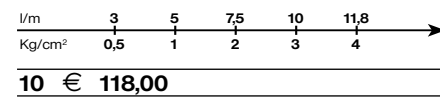

06T501

06T502

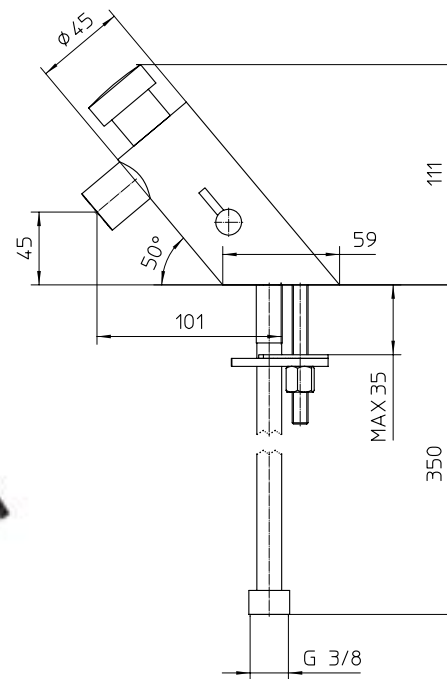

Rubinetto **monoacqua** per lavabo con comando a pressione a chiusura automatica temporizzata, sistema di sicurezza antibloccaggio, temporizzazione 15" impostata in fabbrica, senza scarico.

Washbasin timed **single water tap** with pressure-controlled automatic closing timer, anti-blocking safety system, factory time setting at 15", without waste.

Robinet mono à fermeture automatique temporisé pour lavabo, système de sécurité antiblocage, temporisation 15" réglée en usine, sans vidage.

Selbstschluss **Armatur** für Kaltwasser, Vandalensicher, Laufzeit 15" Werkseitig eingestellt ohne Ablaufgarnitur.

Grifo monoagua temporizado para lavabo, sistema de seguridad antibloqueo, temporización de 15" configurada de fábrica, sin desagüe.

Rubinetto **monoacqua** per lavabo con comando a pressione a chiusura automatica temporizzata, temporizzazione 15" impostata in fabbrica, senza scarico.

Washbasin timed **single water tap** with pressure-controlled automatic closing timer, factory time setting at 15", without waste.

Robinet mono à fermeture automatique temporisé pour lavabo, temporisation 15" réglée en usine, sans vidage.

Selbstschluss **Armatur** für Kaltwasser, Laufzeit 15" Werkseitig eingestellt ohne Ablaufgarnitur.

Grifo monoagua temporizado para lavabo, temporización de 15" configurada de fábrica, sin desagüe.

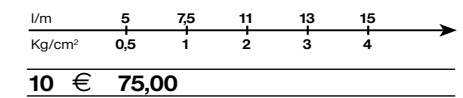
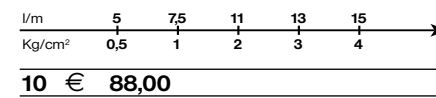

06T503

06T505

06T504

06T506

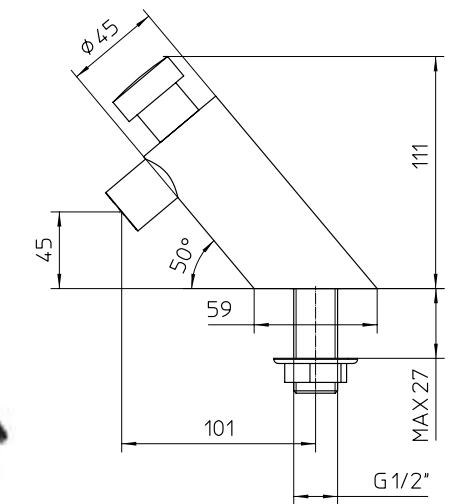

elettronici e temporizzati



temporizzato

sistemi doccia

doccia





Colonna doccia con miscelatore **monocomando**, deviatore a **4 uscite**, flessibile 1,5m e doccia.

Shower column with single control mixer, 4 outlets diverter, flexible tube 1,5m and handshower.

Colonne de douche avec mitigeur monocommande, inverseur à 4 sorties, flexible 1,5m et douche.

Dusch Säule mit Einhebelmischer, 4-Wegeumsteller, Brauseschlauch 1,5m und Handbrause.

Column de ducha con mezclador monomando, desviador a 4 salidas, flexible 1,5m y ducha de mano.

Producto no comercializado en España.

l/m ³	8	11	15	18	21
kg/cm ²	0,5	1	2	3	4

10 € 1.730,00

962490

Colonna doccia con miscelatore **monocomando**, deviatore a **3 uscite**.

Shower column with single control mixer, 3 outlets diverter.

Colonne de douche avec mitigeur monocommande, inverseur à 3 sorties.

Dusch Säule mit Einhebelmischer, 3-Wegeumsteller.

Column de ducha con mezclador monomando, desviador a 3 salidas.

Producto no comercializado en España.

l/m ³	8	11	15	18	21
kg/cm ²	0,5	1	2	3	4

10 € 1.630,00

962491

monocomando



Colonna doccia con miscelatore **termostatico**, deviatore a **4 uscite**, flessibile 1,5m e doccia.

Shower column with thermostatic mixer, 4 outlets diverter, flexible tube 1,5m and handshower.

Colonne de douche avec mitigeur thermostatique, inverseur à 4 sorties, flexible 1,5m et douche.

Dusch Säule mit Thermostat-Mischer, 4-Wegeumsteller, Brauseschlauch 1,5m und Handbrause.

Column de ducha con mezclador termostático, desviador a 4 salidas, flexible 1,5m y ducha de mano.

Producto no comercializado en España.

l/m ³	12	17	21	23	27
kg/cm ²	1	2	3	4	5

10 € 1.810,00

962492

Colonna doccia con miscelatore **termostatico**, deviatore a **3 uscite**.

Shower column with thermostatic mixer, 3 outlets diverter.

Colonne de douche avec mitigeur thermostatique, inverseur à 3 sorties.

Dusch Säule mit Thermostat-Mischer, 3-Wegeumsteller.

Column de ducha con mezclador termostático, desviador a 3 salidas.

Producto no comercializado en España.

l/m ³	12	17	21	23	27
kg/cm ²	1	2	3	4	5

10 € 1.710,00

962493

termostatico

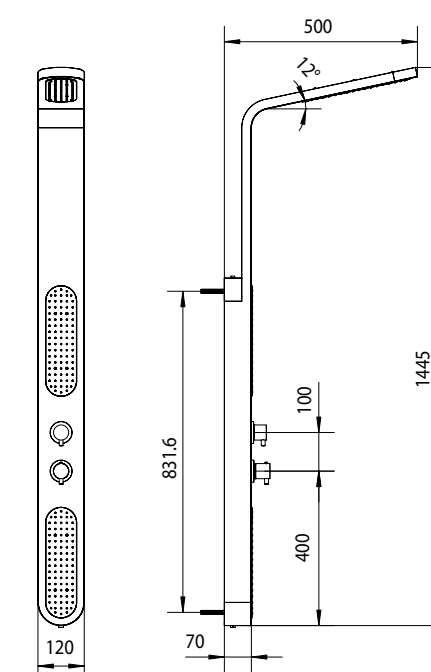
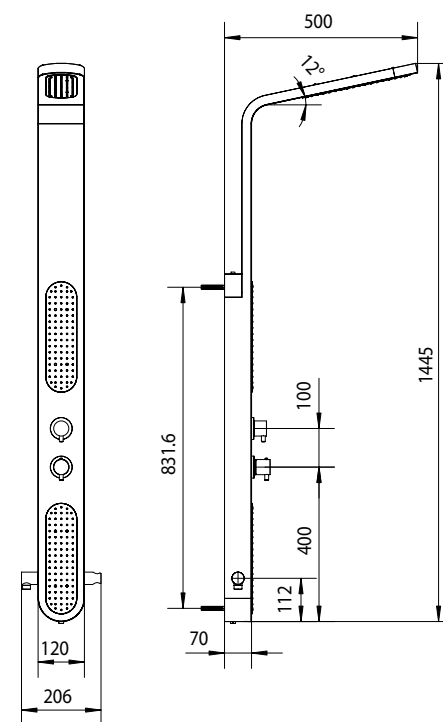
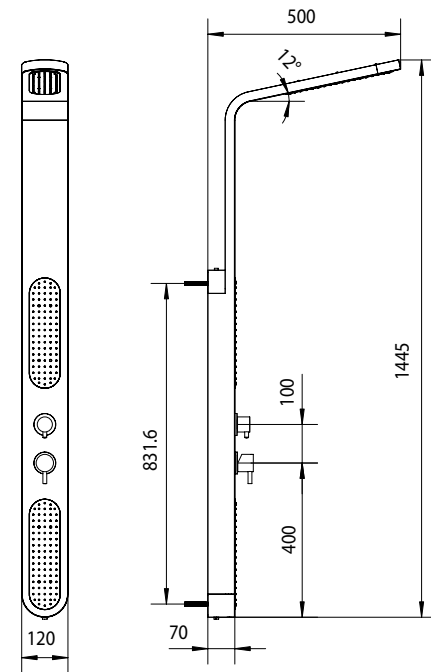
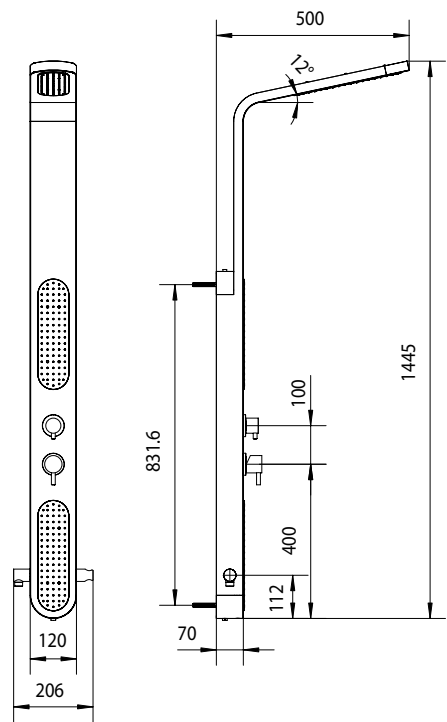

Colonna doccia in ceramica con miscelatore **monocomando**, deviatore a **4 uscite**, flessibile 1,5m e doccia.

Ceramic shower column with single control mixer, 4 outlets diverter, flexible tube 1,5m and handshower.

Colonne de douche céramique avec mitigeur monocommande, inverseur à 4 sorties, flexible 1,5m et douche.

Keramik Dusch Säule mit Einhebelmischer, 4-Wegeumsteller, Brauseschlauch 1,5m und Handbrause.

Columna de ducha de cerámica con mezclador monomando, desviador a 4 salidas, flexible 1,5m y ducha de mano.

l/m ¹	11	15	21	25	29
kg/cm ²	0,5	1	2	3	4

10 € 1.670,00

122509

Colonna doccia in ceramica con miscelatore **monocomando**, deviatore a **2 uscite**, flessibile 1,5m e doccia.

Ceramic shower column with single control mixer, 2 outlets diverter, flexible tube 1,5m and handshower.

Colonne de douche céramique avec mitigeur monocommande, inverseur à 2 sorties, flexible 1,5m et douche.

Keramik Dusch Säule mit Einhebelmischer, 2-Wegeumsteller, Brauseschlauch 1,5m und Handbrause.

Columna de ducha de cerámica con mezclador monomando, desviador a 2 salidas, flexible 1,5m y ducha de mano.

l/m ¹	11	15	21	25	29
kg/cm ²	0,5	1	2	3	4

10 € 1.415,00

122511

Colonna doccia in ceramica con miscelatore **termostatico**, deviatore a **4 uscite**, flessibile 1,5m e doccia.

Ceramic shower column with thermostatic mixer, 4 outlets diverter, flexible tube 1,5m and handshower.

Colonne de douche céramique avec mitigeur thermostatique, inverseur à 4 sorties, flexible 1,5m et douche.

Keramik Dusch Säule mit Thermostat-Mischer, 4-Wegeumsteller, Brauseschlauch 1,5m und Handbrause.

Columna de ducha de cerámica con mezclador termostático, desviador a 4 salidas, flexible 1,5m y ducha de mano.

l/m ¹	14	20	24	28	31
kg/cm ²	1	2	3	4	5

10 € 1.750,00

132508

Colonna doccia in ceramica con miscelatore **termostatico**, deviatore a **2 uscite**, flessibile 1,5m e doccia.

Ceramic shower column with thermostatic mixer, 2 outlets diverter, flexible tube 1,5m and handshower.

Colonne de douche céramique avec mitigeur thermostatique, inverseur à 2 sorties, flexible 1,5m et douche.

Keramik Dusch Säule mit Thermostat-Mischer, 2-Wegeumsteller, Brauseschlauch 1,5m und Handbrause.

Columna de ducha de cerámica con mezclador termostático, desviador a 2 salidas, flexible 1,5m y ducha de mano.

l/m ¹	14	20	24	28	31
kg/cm ²	1	2	3	4	5

10 € 1.495,00

132510

monocomando

termostatico

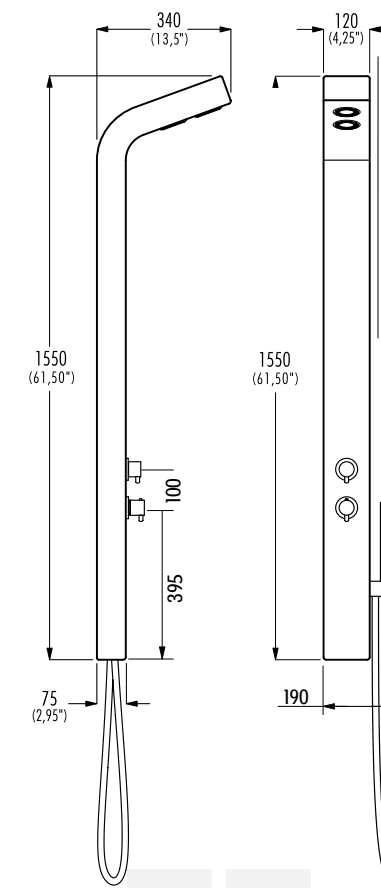
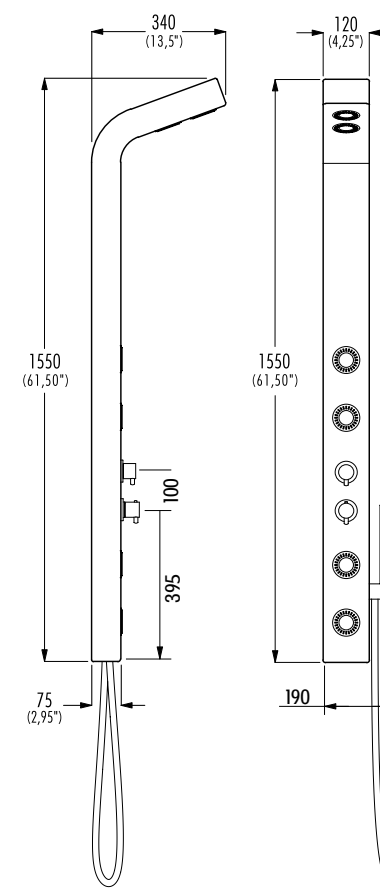
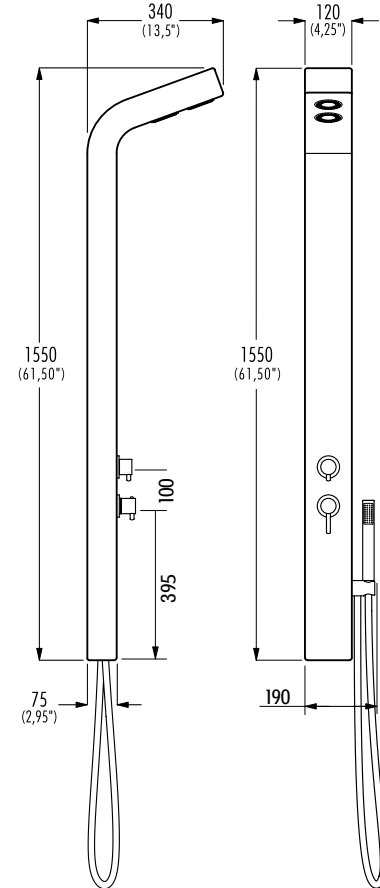
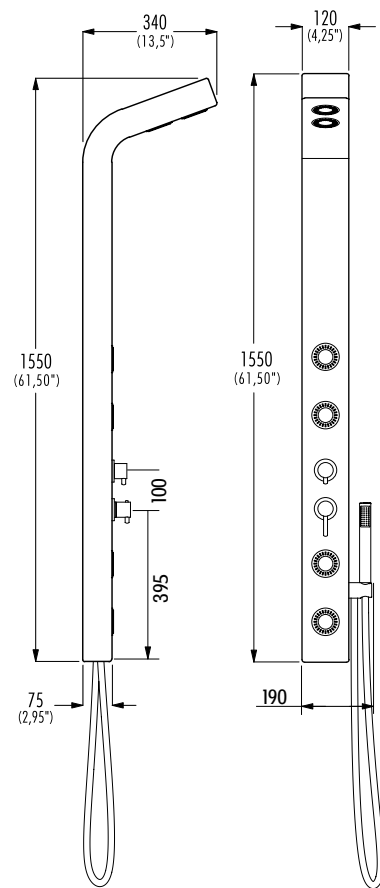

[ceramica]

[ceramica]

Colonna doccia in ceramica con miscelatore **monocomando**, deviatore a 4 uscite, flessibile 1,5m e doccia.

Ceramic shower column with single control mixer, 4 outlets diverter, flexible tube 1,5m and handshower.

Colonne de douche céramique avec mitigeur monocommande, inverseur à 4 sorties, flexible 1,5m et douche.

Keramik Dusch Säule mit Einhebelmischer, 4-Wegeumsteller, Brauseschlauch 1,5m und Handbrause.

Columna de ducha de cerámica con mezclador monomando, desviador a 4 salidas, flexible 1,5m y ducha de mano.

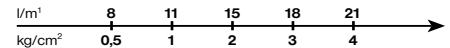

10 € 915,00

Colonna doccia in ceramica con miscelatore **termostatico**, deviatore a 4 uscite, flessibile 1,5m e doccia.

Ceramic shower column with thermostatic mixer, 4 outlets diverter, flexible tube 1,5m and handshower.

Colonne de douche céramique avec mitigeur thermostatique, inverseur à 4 sorties, flexible 1,5m et douche.

Keramik Dusch Säule mit Thermostat-Mischer, 4-Wegeumsteller, Brauseschlauch 1,5m und Handbrause.

Columna de ducha de cerámica con mezclador termostático, desviador a 4 salidas, flexible 1,5m y ducha de mano.

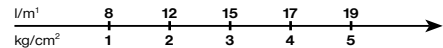

10 € 995,00

122521

962516

[ceramica]

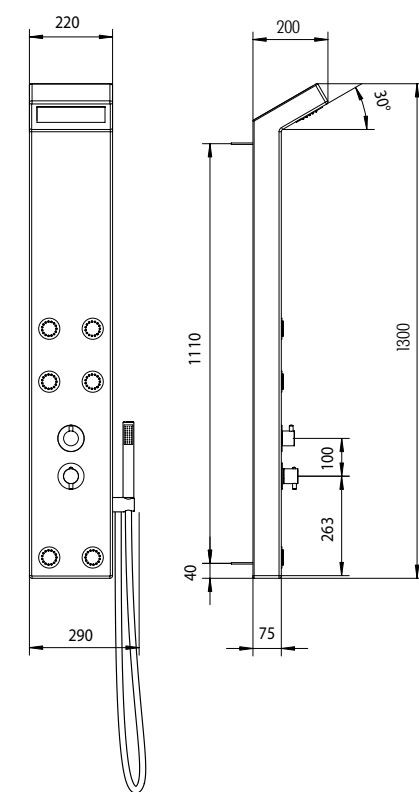
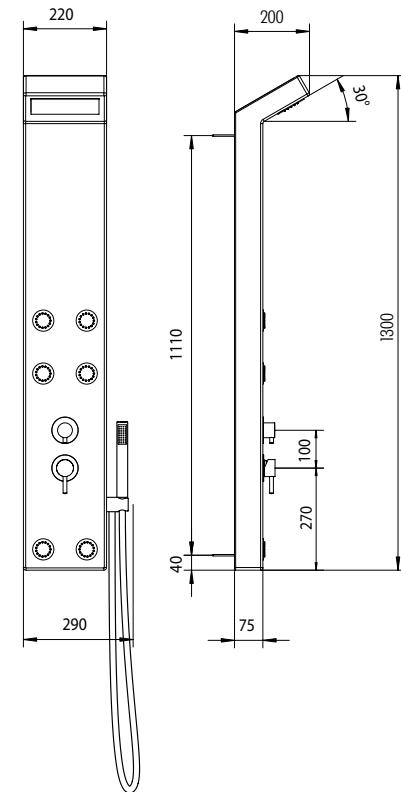
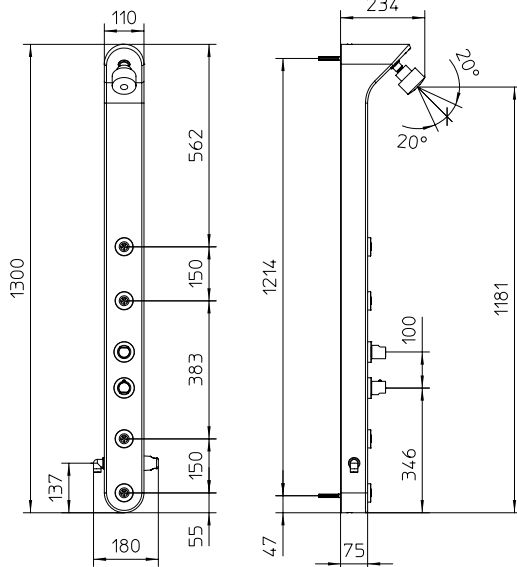
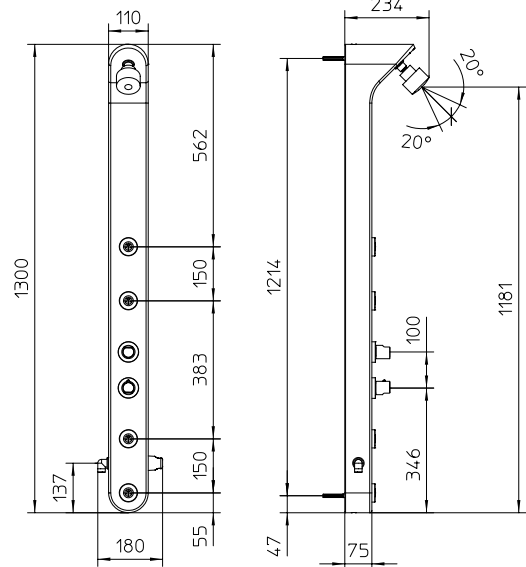

122507

962506

[ceramica]

Colonna doccia in ceramica con miscelatore **monocomando**, deviatore a 4 uscite, flessibile 1,5m e doccia.

Ceramic shower column with single control mixer, 4 outlets diverter, flexible tube 1,5m and handshower.

Colonne de douche céramique avec mitigeur monocommande, inverseur à 4 sorties, flexible 1,5m et douche.

Keramik Dusch Säule mit Einhebelmischer, 4-Wegeumsteller, Brauseschlauch 1,5m und Handbrause.

Columna de ducha de cerámica con mezclador monomando, desviador a 4 salidas, flexible 1,5m y ducha de mano.

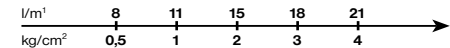

10 € 1.695,00

Colonna doccia in ceramica con miscelatore **termostatico**, deviatore a 4 uscite, flessibile 1,5m e doccia.

Ceramic shower column with thermostatic mixer, 4 outlets diverter, flexible tube 1,5m and handshower.

Colonne de douche céramique avec mitigeur thermostatique, inverseur à 4 sorties, flexible 1,5m et douche.

Keramik Dusch Säule mit Thermostat-Mischer, 4-Wegeumsteller, Brauseschlauch 1,5m und Handbrause.

Columna de ducha de cerámica con mezclador termostático, desviador a 4 salidas, flexible 1,5m y ducha de mano.

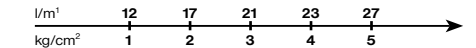

10 € 1.775,00



Colonna doccia in ceramica con miscelatore **monocomando**, deviatore a 4 uscite, flessibile 1,5m e doccia.

Ceramic shower column with single control mixer, 4 outlets diverter, flexible tube 1,5m and handshower.

Colonne de douche céramique avec mitigeur monocommande, inverseur à 4 sorties, flexible 1,5m et douchette.

Keramik Dusch Säule mit Einhebelmischer, 4-Wegeumsteller, Brauseschlauch 1,5m und Handbrause.

Columna de ducha de cerámica con mezclador monomando, desviador a 4 salidas, flexible 1,5m y ducha de mano.

l/m ¹	11	15	21	25	29
kg/cm ²	0,5	1	2	3	4

10 € 1.569,00

Colonna doccia in ceramica con miscelatore **termostatico**, deviatore a 4 uscite, flessibile 1,5m e doccia.

Ceramic shower column with thermostatic mixer, 4 outlets diverter, flexible tube 1,5m and handshower.

Colonne de douche céramique avec mitigeur thermostatique, inverseur à 4 sorties, flexible 1,5m et douchette.

Keramik Dusch Säule mit Thermostat-Mischer, 4-Wegeumsteller, Brauseschlauch 1,5m und Handbrause.

Columna de ducha de cerámica con mezclador termostático, desviador a 4 salidas, flexible 1,5m y ducha de mano.

l/m ¹	14	20	24	28	31
kg/cm ²	1	2	3	4	5

10 € 1.649,00

122513

132512

[ceramica]

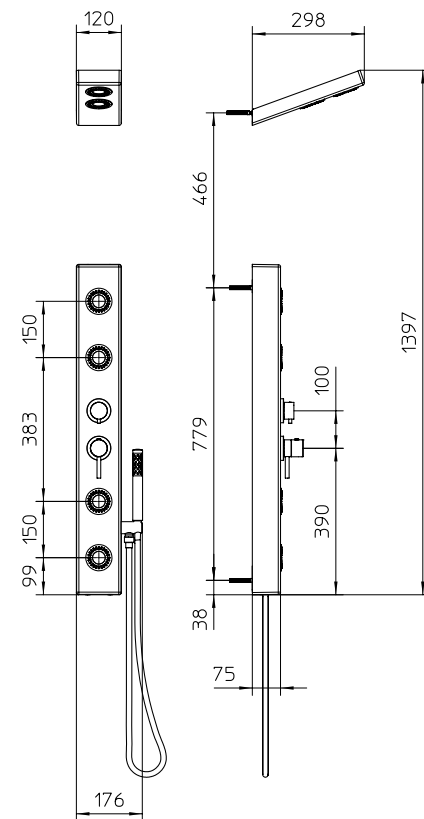
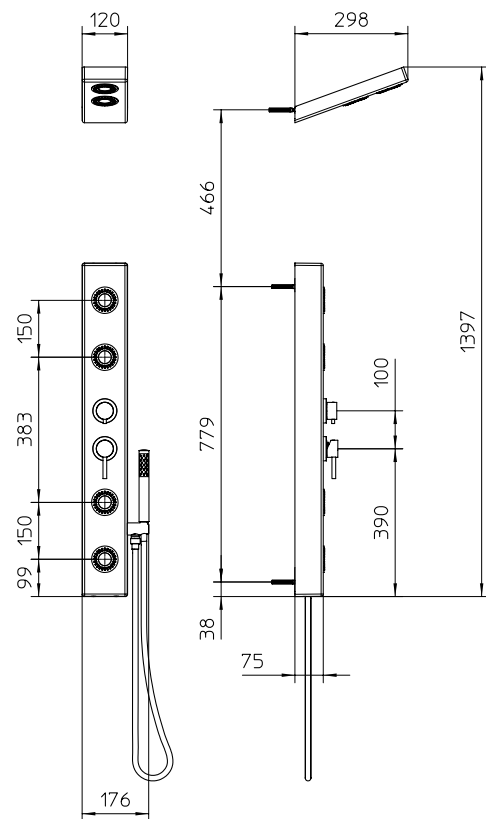
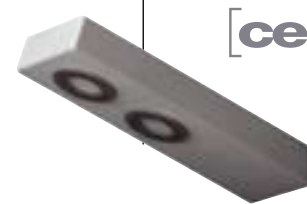

Colonna doccia in ceramica con miscelatore **monocomando**, deviatore a 4 uscite, flessibile 1,5m e doccia.

Ceramic shower column with single control mixer, 4 outlets diverter, flexible tube 1,5m and handshower.

Colonne de douche céramique avec mitigeur monocommande, inverseur à 4 sorties, flexible 1,5m et douchette.

Keramik Dusch Säule mit Einhebelmischer, 4-Wegeumsteller, Brauseschlauch 1,5m und Handbrause.

Columna de ducha de cerámica con mezclador monomando, desviador a 4 salidas, flexible 1,5m y ducha de mano.

l/m ¹	11	15	21	25	29
kg/cm ²	0,5	1	2	3	4

10 € 1.290,00

Colonna doccia in ceramica con miscelatore **termostatico**, deviatore a 4 uscite, flessibile 1,5m e doccia.

Ceramic shower column with thermostatic mixer, 4 outlets diverter, flexible tube 1,5m and handshower.

Colonne de douche céramique avec mitigeur thermostatique, inverseur à 4 sorties, flexible 1,5m et douchette.

Keramik Dusch Säule mit Thermostat-Mischer, 4-Wegeumsteller, Brauseschlauch 1,5m und Handbrause.

Columna de ducha de cerámica con mezclador termostático, desviador a 4 salidas, flexible 1,5m y ducha de mano.

l/m ¹	14	20	24	28	31
kg/cm ²	1	2	3	4	5

10 € 1.370,00

122518

132517

[ceramica]

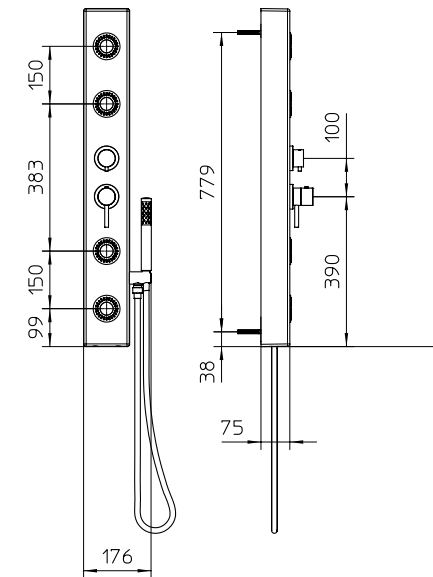
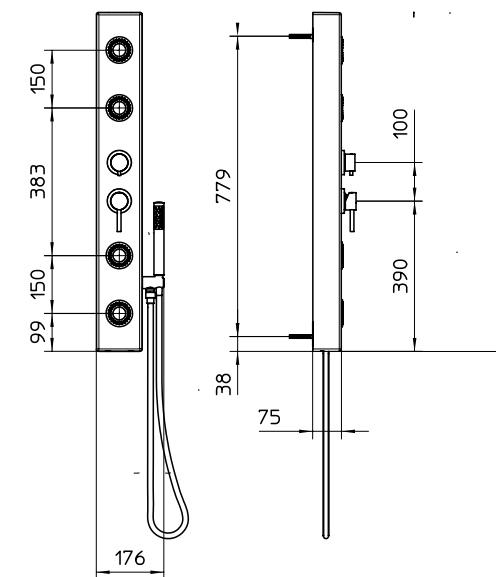

band

Colonna doccia e soffione, in ceramica, con miscelatore **monocomando**, deviatore a 4 uscite, flessibile 1,5m e doccetta.

Ceramic shower column and ceramic headshower, single control mixer, 4 outlets diverter, flexible tube 1,5m and handshower.

Colonne de douche et pomme de douche en céramique, mitigeur monocommande, inverseur à 4 sorties, flexible 1,5m et douchette.

Keramik Dusch Säule und Kopfdusche, Einhebelmischer, 4-Wegeumsteller, Brauseschlauch 1,5m und Handbrause.

Column de ducha y rociador de cerámica, mezclador monomando, desviador a 4 salidas, flexible 1,5m y ducha de mano.

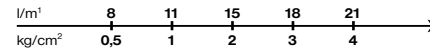

10 € 1.899,00

Colonna doccia e soffione, in ceramica, con miscelatore **termostatico**, deviatore a 4 uscite, flessibile 1,5m e doccetta.

Ceramic shower column and ceramic headshower, thermostatic mixer, 4 outlets diverter, flexible tube 1,5m and handshower.

Colonne de douche et pomme de douche en céramique, mitigeur thermostatique, inverseur à 4 sorties, flexible 1,5m et douchette.

Keramik Dusch Säule und Kopfdusche, Thermostat-Mischer, 4-Wegeumsteller, Brauseschlauch 1,5m und Handbrause.

Column de ducha y rociador de cerámica, mezclador termostático, desviador a 4 salidas, flexible 1,5m y ducha de mano.

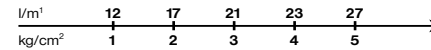

10 € 1.979,00

122515

962514

[ceramica]

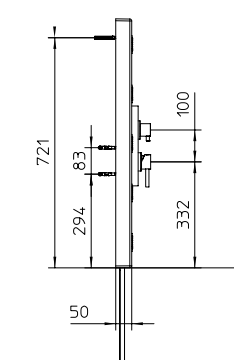
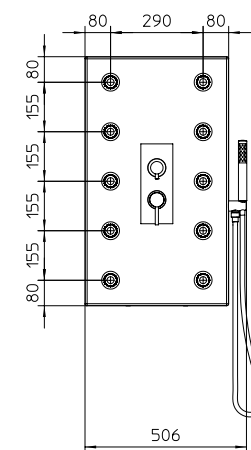
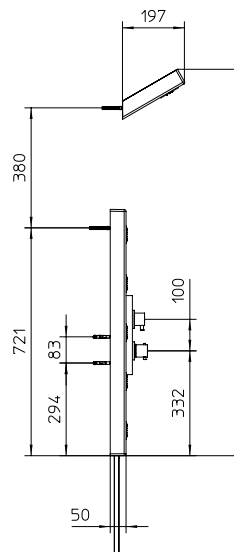
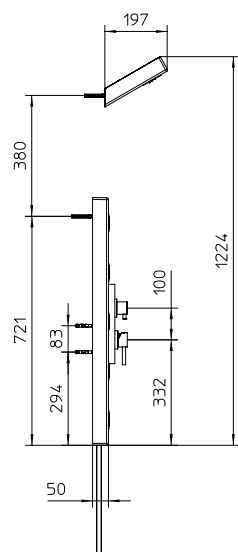
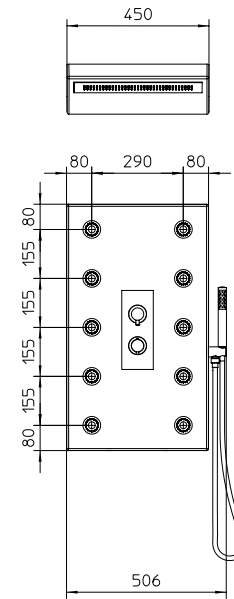
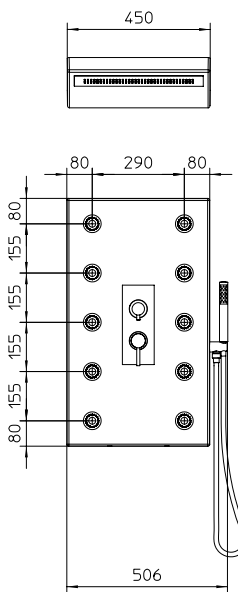

122520

962519

[ceramica]

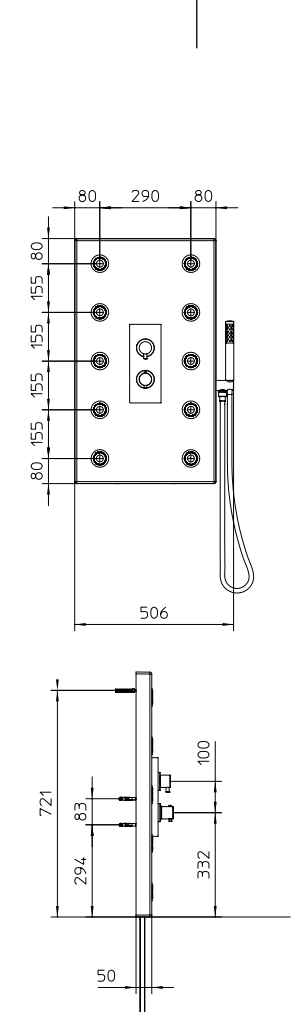

band

sistemi doccia

Soffione doccia in ceramica a 2 getti.
 Ceramic headshower, 2 jets spray.
 Pomme de douche en ceramique, 2 jets.
 Keramik Kopfdusche, 2-Strahl.
 Rociador de cerámica, 2 chorros.

Soffione doccia in ceramica a 1 getto.
 Ceramic headshower, 1 jet spray.
 Pomme de douche en ceramique, 1 jet.
 Keramik Kopfdusche, 1-Strahl.
 Rociador de cerámica, 1 chorro.

Soffione doccia in ceramica.
 Ceramic headshower.
 Pomme de douche en ceramique.
 Keramik Kopfdusche.
 Rociador de cerámica.

10 € 279,00

10 € 199,00

10 € 379,00

992678

992679

992680

[ceramica]

[ceramica]

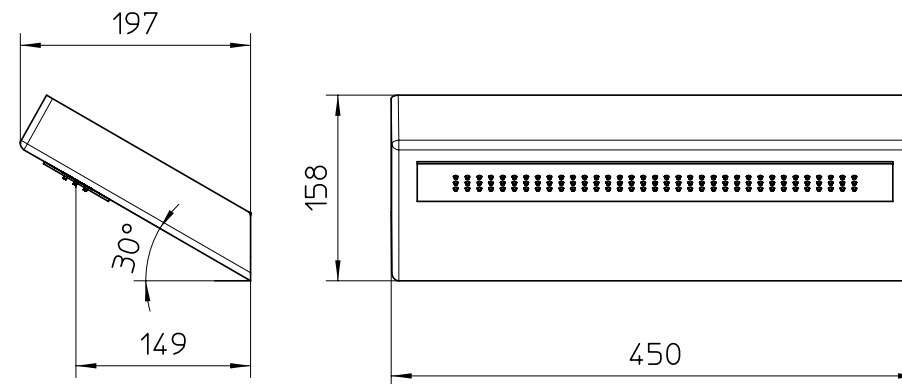
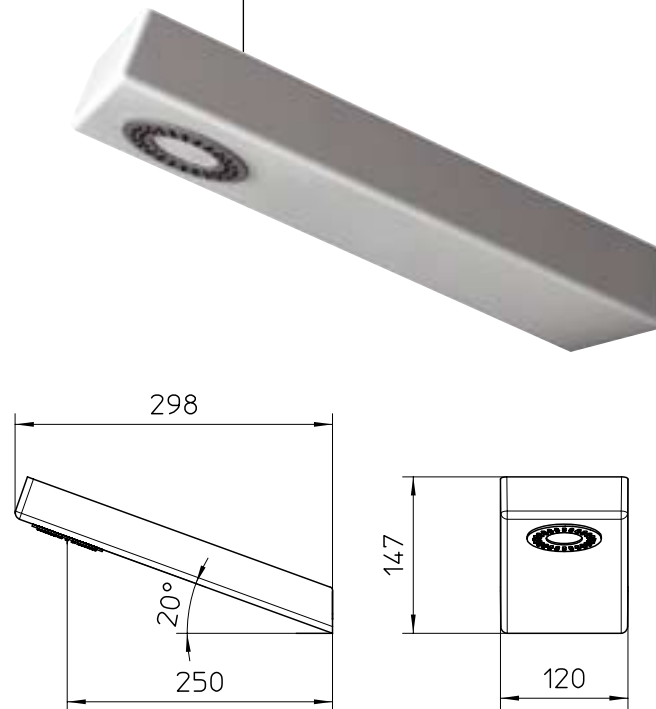
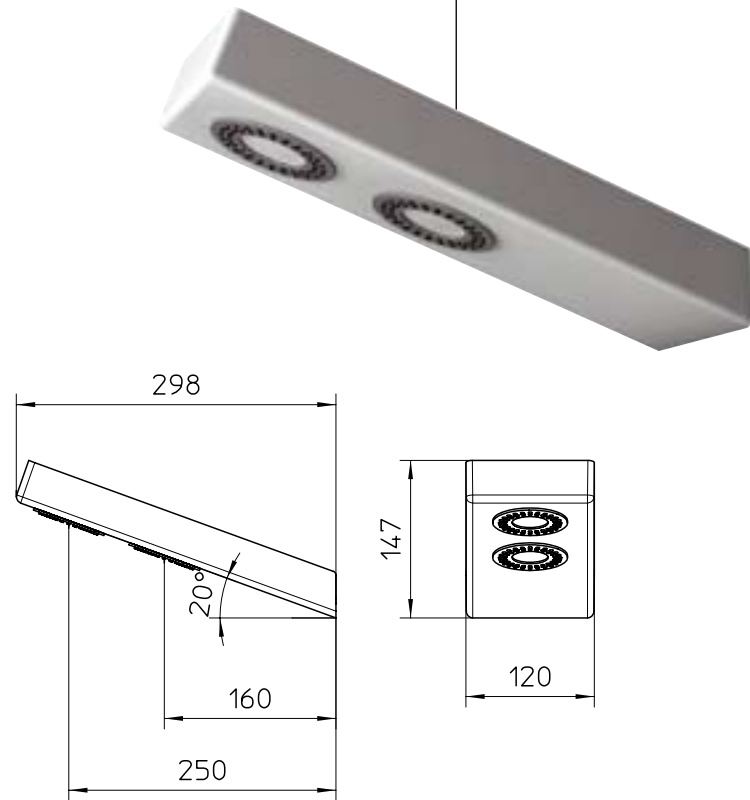

band

Colonna doccia Digit con soffione Easy-clean ø 200 mm.
Digit shower column, Easy-clean shower rose ø 200 mm.
Colonne de douche Digit, avec pomme Easy-clean ø 200 mm.
Digit Standbrauserohr, mit Easy-clean Dusche ø 200 mm.
Columna de ducha Digit con rociador Easy-clean ø 200 mm.

l/m	16	23	32	37	42
Kg/cm2	0,5	1	2	3	4
	10 € 369,00				

992681

Colonna doccia Digit con soffione Easy-clean ø 200 mm, deviatore, flessibile e doccia.
Digit shower column, Easy-clean shower rose ø 200 mm, diverter, flexible and handshower.
Colonne de douche Digit avec pomme Easy-clean ø 200 mm, inverseur, flexible et douchette.
Digit Standbrauserohr mit Easy-clean Dusche ø 200 mm, Umstellung, Brauseschlauch und Handbrause.
Columna de ducha Digit con rociador Easy-clean ø 200 mm, desviador, flexible y ducha.

l/m	9	13	18	23	26
Kg/cm2	0,5	1	2	3	4
	10 € 449,00				

992682



Miscelatore monocomando con colonna doccia Digit, soffione Easy-clean ø 200 mm, deviatore, flessibile e doccia.
Single control mixer, Digit shower column, Easy-clean shower rose ø 200 mm, diverter, flexible and handshower.
Mitigeur monocommande, colonne de douche Digit avec pomme Easy-clean ø 200 mm, inverseur, flexible et douchette.
Einhebelmischer, Digit Standbrauserohr mit Easy-clean Dusche ø 200 mm, Umstellung, Brauseschlauch und Handbrause.
Mezclador monomando, columna de ducha Digit con rociador Easy-clean ø 200 mm, desviador, flexible y ducha.

l/m	7	10	14	18	21
Kg/cm2	0,5	1	2	3	4
	10 € 564,00				

122125

Miscelatore termostatico, uscita superiore 3/4", uscita inferiore 1/2", colonna doccia Digit, soffione Easy-clean ø 200 mm, deviatore, flessibile e doccia.
Thermostatic mixer, upper side 3/4" outlet, low outlet 1/2", Digit shower column, Easy-clean shower rose ø 200 mm, diverter, flexible and handshower.
Mitigeur thermostatique, sortie supérieure 3/4", sortie inférieure 1/2", colonne de douche Digit avec pomme Easy-clean ø 200 mm, inverseur, flexible et douchette.
Thermostat-Mischer, 3/4" oberer Ausgang, 1/2" unterer Ausgang, Digit Standbrauserohr mit Easy-clean Dusche ø 200 mm, Umstellung, Brauseschlauch und Handbrause.
Mezclador termostático, salida alta 3/4", salida baja 1/2", columna de ducha Digit con rociador Easy-clean ø 200 mm, desviador, flexible y ducha.

l/m	10	14	18	21	23
Kg/cm2	1	2	3	4	5
	10 € 668,00				

962068

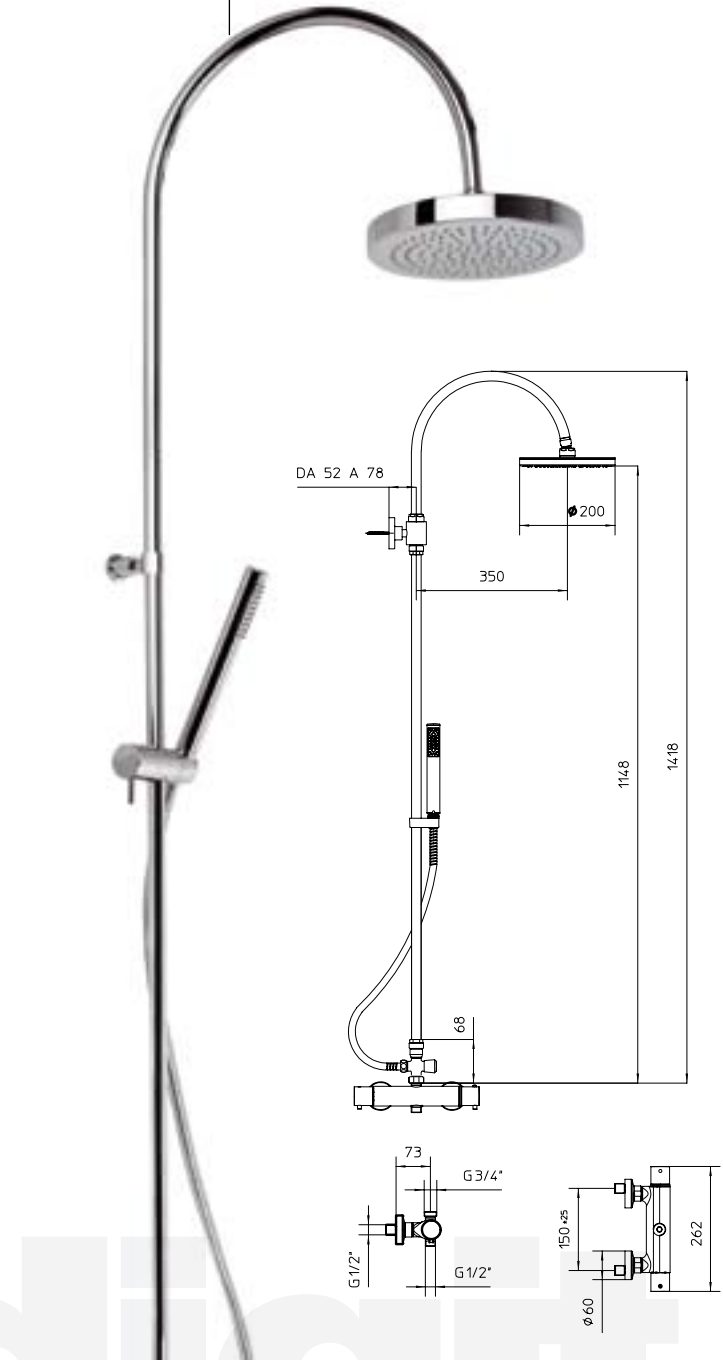
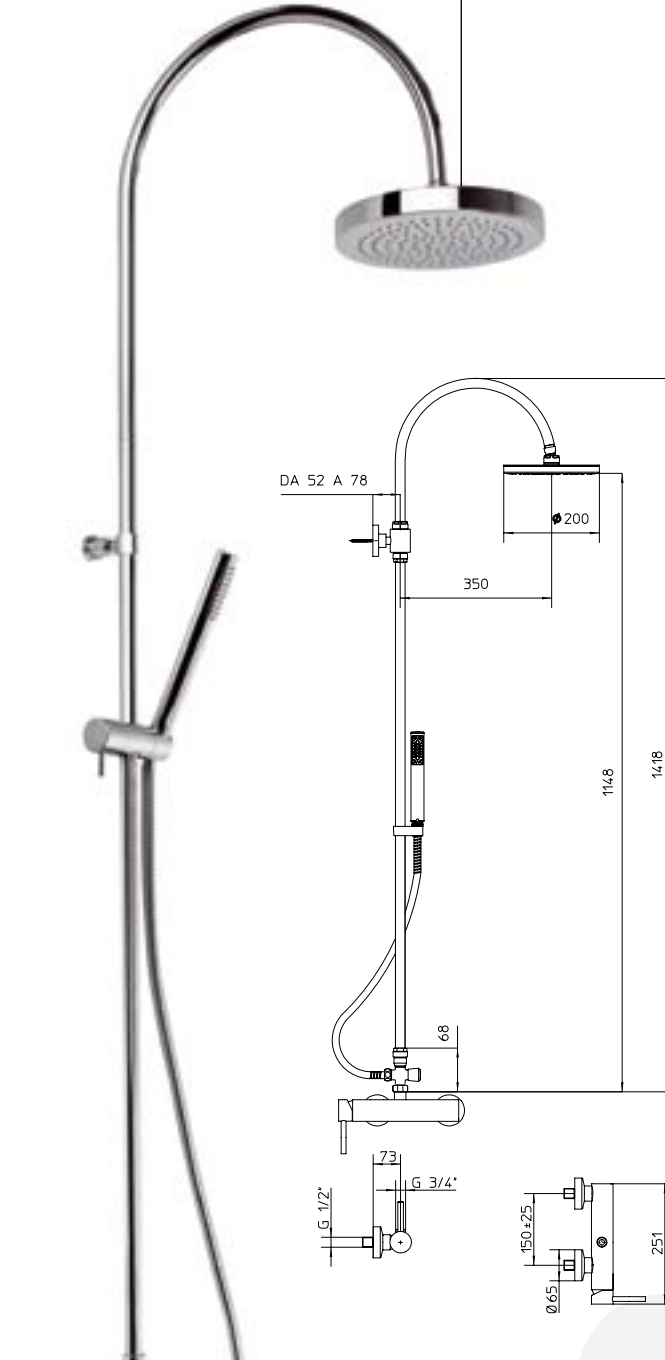
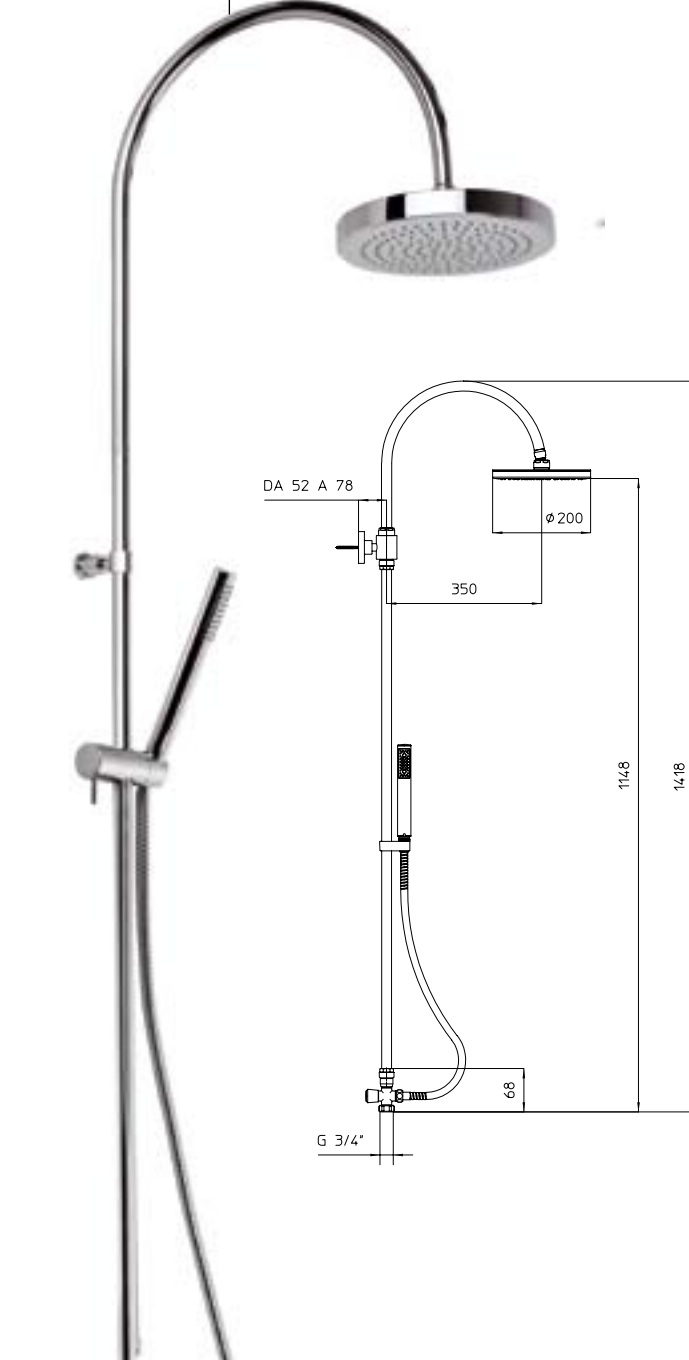
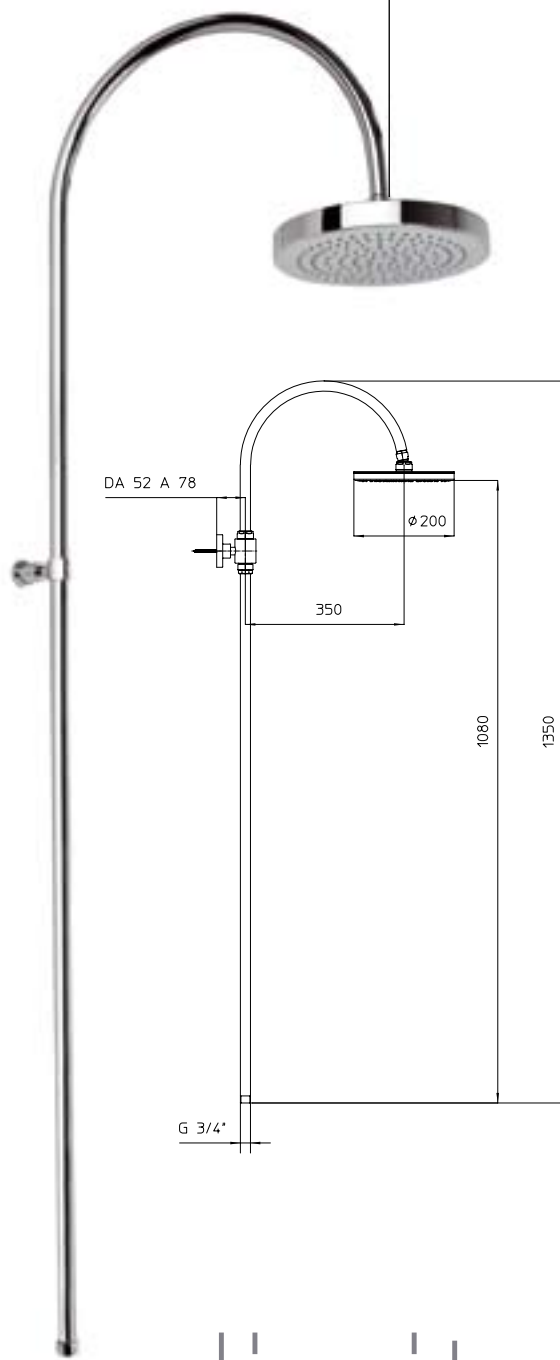

digit

Colonna doccia Kubik con soffione Easy-clean.
 Kubik shower column with Easy-clean shower rose.
 Colonne de douche Kubik avec pomme Easy-clean.
 Kubik Standbrauserohr mit Easy-clean Kopfbrause.
 Columna de ducha Kubik con rociador Easy-clean.

Colonna doccia Kubik con soffione Easy-clean, deviatore, flessibile e doccia.
 Kubik shower column rose, with Easy-clean shower rose, diverter, flexible and handshower.
 Colonne de douche Kubik avec pomme Easy-clean, inverseur, flexible et douchette.
 Kubik Standbrauserohr mit Easy-clean Kopfbrause, Umstellung, Brauseschlauch und Handbrause.
 Columna de ducha Kubik con rociador Easy-clean, desviador, flexible y ducha.

l/m	16	23	32	37	42
Kg/cm2	0,5	1	2	3	4
	10 €	399,00			

l/m	9	13	18	23	24
Kg/cm2	0,5	1	2	3	4
	10 €	479,00			

992683

992684

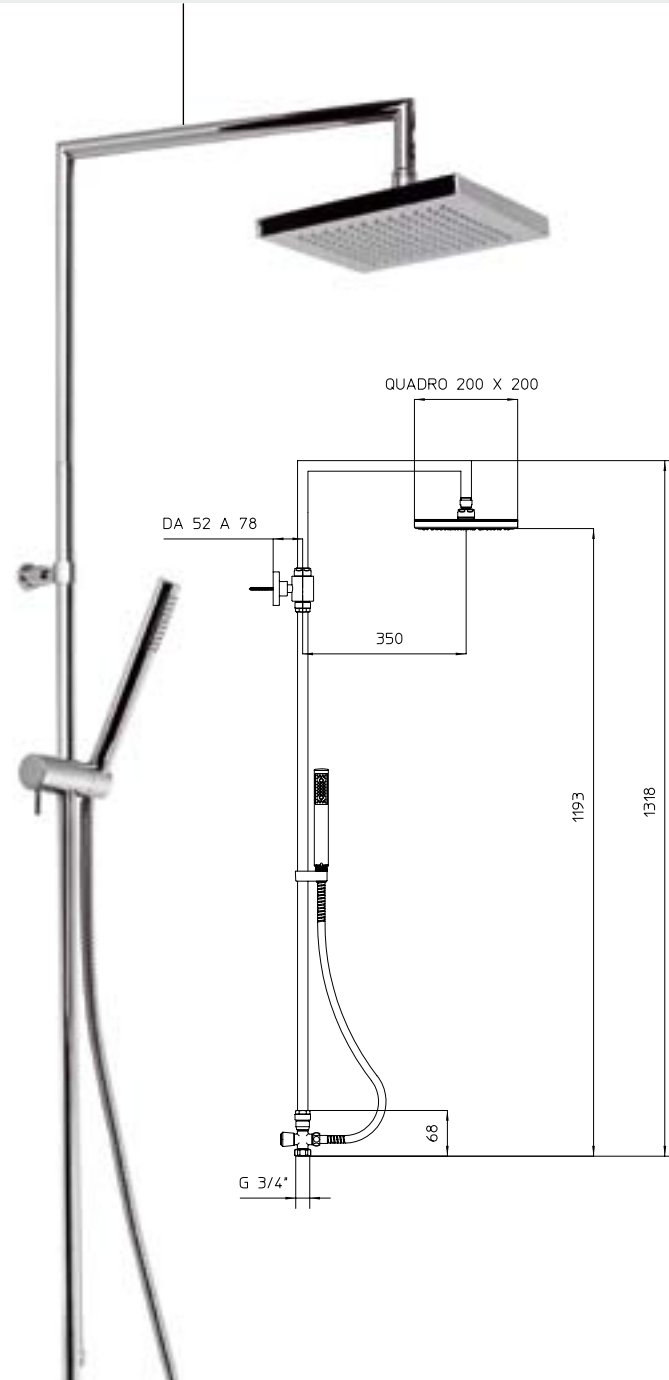
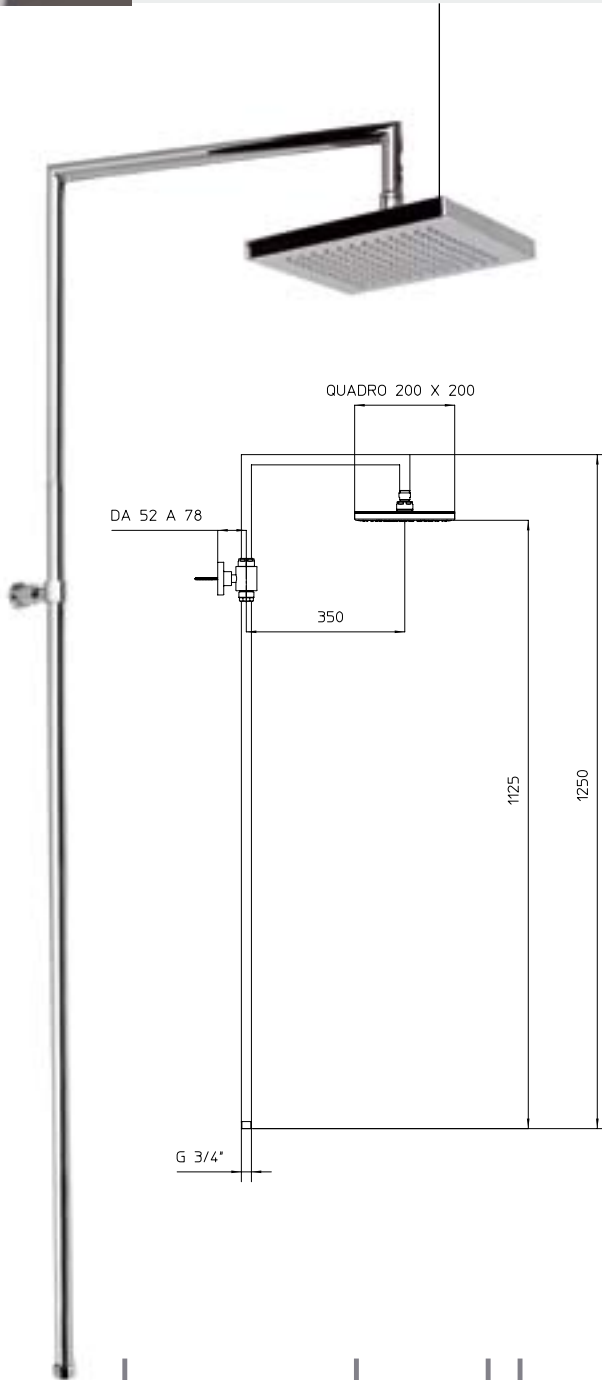

Miscelatore monocomando con colonna doccia Kubik, soffione Easy-clean, deviatore, flessibile e doccia.
 Single control mixer, Kubik shower column, Easy-clean shower rose, diverter, flexible and handshower.
 Mitigeur monocommande, colonne de douche Kubik avec pomme Easy-clean, inverseur, flexible et douchette.
 Einhebelmischer, Kubik Standbrauserohr mit Easy-clean Kopfbrause, Umstellung, Brauseschlauch und Handbrause.
 Mezclador monomando, columna de ducha Kubik con rociador Easy-clean, desviador, flexible y ducha.

Miscelatore termostatico con colonna doccia Kubik, soffione Easy-clean, deviatore, flessibile e doccia.
 Thermostatic mixer, Kubik shower column, Easy-clean shower rose, diverter, flexible and handshower.
 Mitigeur thermostatique, colonne de douche Kubik avec pomme Easy-clean, inverseur, flexible et douchette.
 Thermostat-Mischer, Kubik Standbrauserohr mit Easy-clean Kopfbrause, Umstellung, Brauseschlauch und Handbrause.
 Mezclador termostático, columna de ducha Kubik con rociador Easy-clean, desviador, flexible y ducha.

l/m	7	10	14	18	21
Kg/cm2	0,5	1	2	3	4
	10 €	669,00			

l/m	10	14	18	21	23
Kg/cm2	1	2	3	4	5
	10 €	839,00			

302126

312126

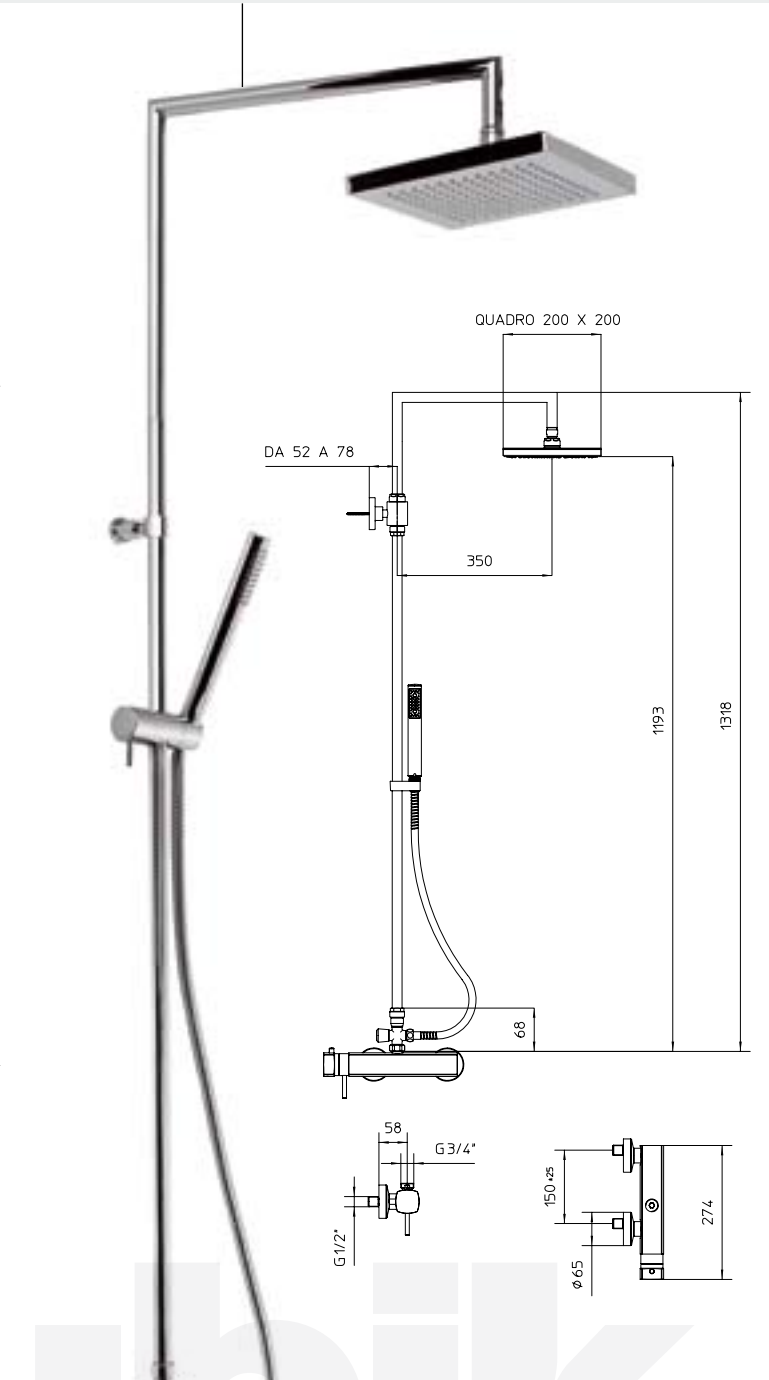
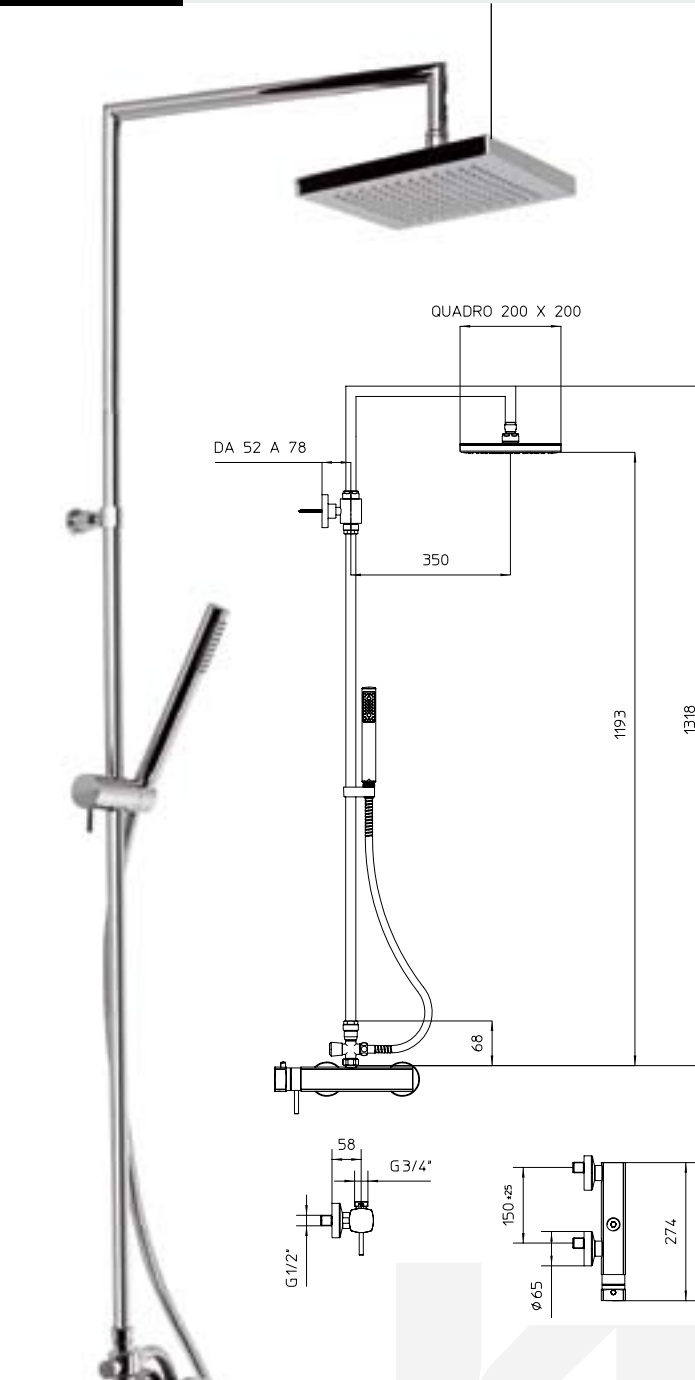

sistemi doccia

cucina

chef



finiture disponibili
available finishes
finition disponibles
verfügbare Farben
acabados disponibles

10 Cromo - Chrome
Chromé - Chrom



Miscelatore monocomando per lavello con bocca girevole.

Single lever sink mixer with swivel spout.

Mitigeur monocommande d'évier, bec orientable

Einhand-Spültischmischer, schwenkbare Auslauf,

Mezclador monomando fregadero, caño giratorio.

Miscelatore monocomando per lavello con doccetta estraibile a 2 getti.

Single lever sink mixer, pull-out shower 2 jets spray.

Mitigeur monocommande d'évier, douchette amovible, 2 jets.

Einhand-Spültischmischer, schwenkauslauf, verstellbare 2-Strahl-Handbrause.

Mezclador monomando fregadero, duche extraible 2 chorros.

l/m	6	8	11	13	15
Kg/cm ²	0,5	1	2	3	4
10	€ 270,00				

l/m	3,3	4,8	7,2	9	10,5
Kg/cm ²	0,5	1	2	3	4
10	€ 395,00				

Miscelatore monocomando per lavello con bocca girevole.

Single lever sink mixer with swivel spout.

Mitigeur monocommande d'évier, bec orientable

Einhand-Spültischmischer, schwenkbare Auslauf,

Mezclador monomando fregadero, caño giratorio.

l/m	3,3	4,8	7,2	9	10,5
Kg/cm ²	0,5	1	2	3	4
10	€ 240,00				

Miscelatore monocomando per lavello con bocca girevole.

Single lever sink mixer with swivel spout.

Mitigeur monocommande d'évier, bec orientable

Einhand-Spültischmischer, schwenkbare Auslauf,

Mezclador monomando fregadero, caño giratorio.

l/m	3,3	4,8	7,2	9	10,5
Kg/cm ²	0,5	1	2	3	4
10	€ 250,00				

Miscelatore monocomando per lavello con bocca girevole.

Single lever sink mixer with swivel spout.

Mitigeur monocommande d'évier, bec orientable

Einhand-Spültischmischer, schwenkbare Auslauf,

Mezclador monomando fregadero, caño giratorio.

l/m	3,3	4,8	7,2	9	10,5
Kg/cm ²	1	2	3	4	5
10	€ 290,00				

565020

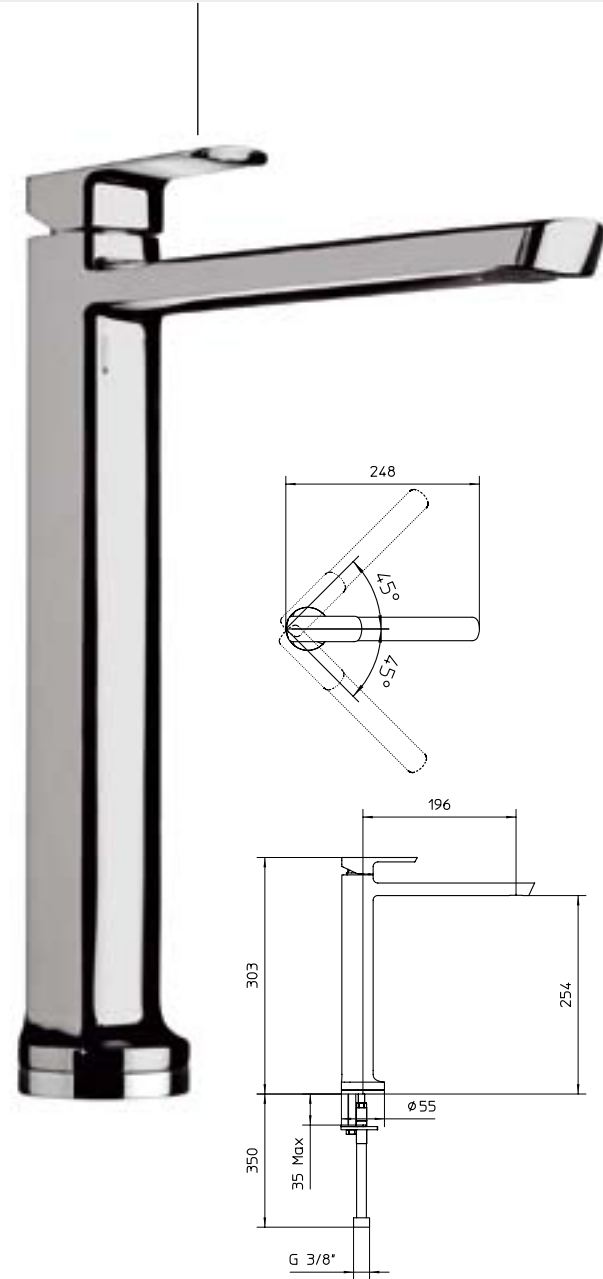

105344



105337



105338



105339



Miscelatore monocomando per lavello con bocca girevole.

Single lever sink mixer with swivel spout.

Mitigeur monocommande d'évier, bec orientable

Einhand-Spültischmischer, schwenkbare Auslauf,

Mezclador monomando fregadero, caño giratorio.

Miscelatore monocomando per lavello con bocca girevole.

Single lever sink mixer with swivel spout.

Mitigeur monocommande d'évier, bec orientable

Einhand-Spültischmischer, schwenkbare Auslauf,

Mezclador monomando fregadero, caño giratorio.

Miscelatore monocomando per lavello con bocca girevole.

Single lever sink mixer with swivel spout.

Mitigeur monocommande d'évier, bec orientable

Einhand-Spültischmischer, schwenkbare Auslauf,

Mezclador monomando fregadero, caño giratorio.

Miscelatore monocomando, corpo orizzontale, bocca angolare.

Single control mixer, horizontal body with square spout.

Mitigeur monocommande, corps horizontal, bec coudé.

Waschtisch Einhebelmischer, mit waagrechtem Körper, Bogenauslauf.

Mezclador monomando con cuerpo horizontal, caño angular.

Miscelatore monocomando, bocca tonda laterale.

Single control mixer with round curved side spout.

Mitigeur monocommande, bec latéral courbe.

Waschtisch Einhebelmischer, Einloch schwenkbarer seiten Rundenauslauf.

Mezclador monomando con caño lateral redondo.

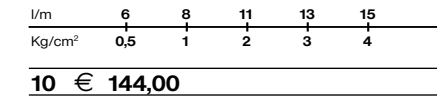
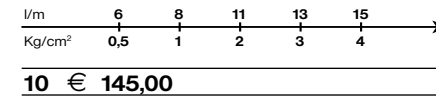
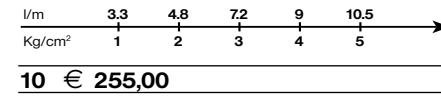
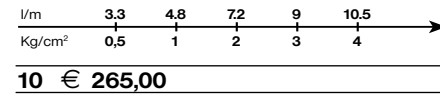
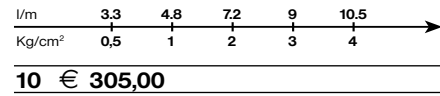

095339



095338



095337



125317

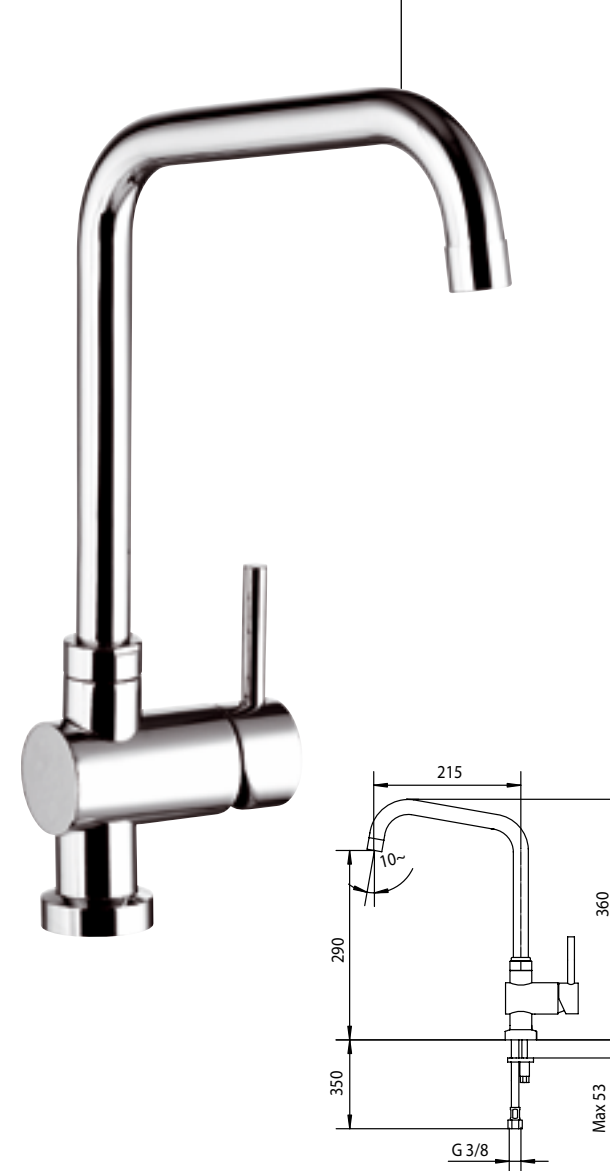

125326



chefina



plavisdesign

ceramiche

plavisdesign



Lavabo da parete, cm 80.
 Wall mounted washbasin, cm 80.
 Lave main mural, cm 80.
 Wand Einbau Waschtisch, cm 80.
 Lavabo mural, cm 80.

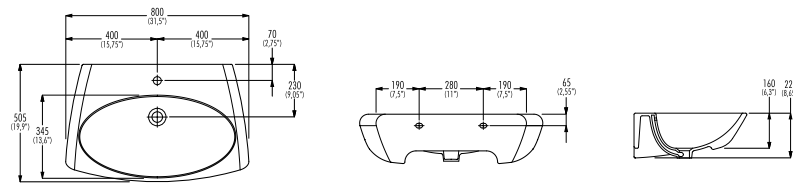

00 € 550,00

C032011

Lavabo da parete, cm 120.
 Wall mounted washbasin, cm 120.
 Lave main mural, cm 120.
 Wand Einbau Waschtisch, cm 120.
 Lavabo mural, cm 120.

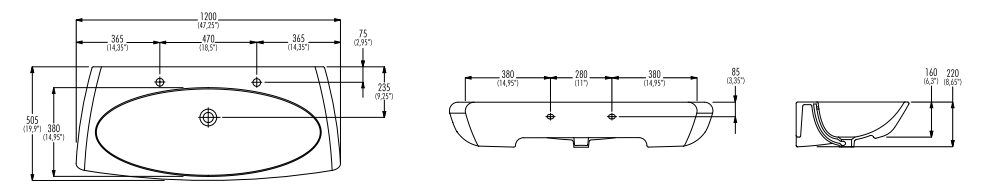

00 € 1.050,00

C032022



Wc sospeso.
Wall mounted wc.
Cuvette suspendue.
Wandtiefspülklosett.
Inodoro suspendido.

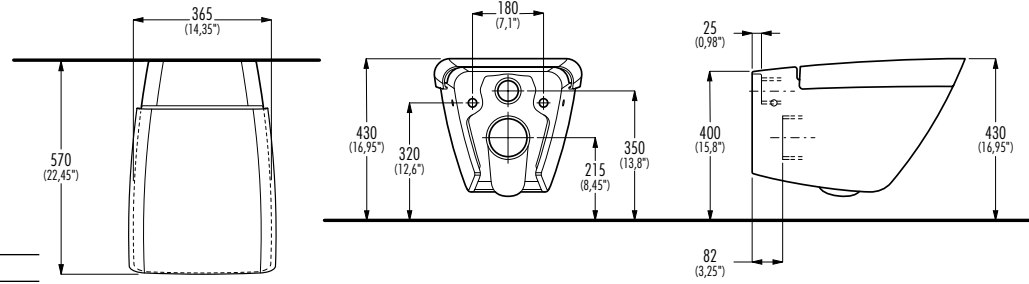

00 € 530,00

C032471

Sedile in termoindurente con chiusura rallentata.
Seat and cover in thermosetting material with soft close.
L'assise et le couvrir sont produits avec du matériel thermosetting, fermeture retardée.
WC Sitz in Duroplast mit Softclosing Schanieren.
Asiento y tapa de resina termoendurencida, de caída amortiguada.

00 € 152,00

C032871

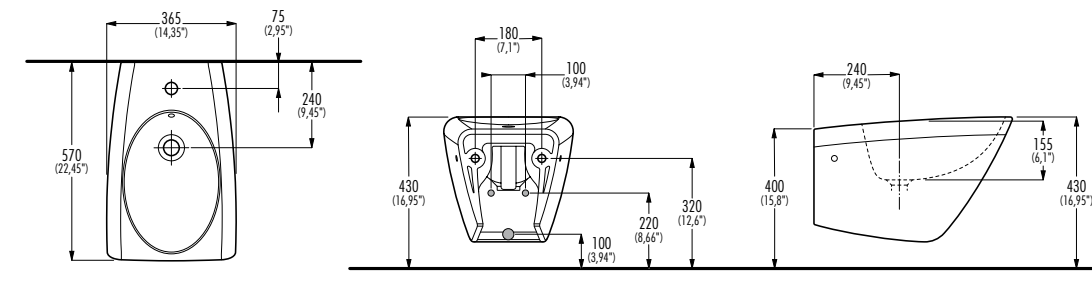

Bidet sospeso.
Wall mounted Bidet.
Bidet suspendu.
Wand Bidet.
Bidé suspendido.

00 € 530,00

C032311

Staffa di fissaggio per vaso e bidet sospeso.
Fixing bracket for wall hung wc/bidet.
Befestigungsmaterial für Wand WC und Wand Bidet.
Support pour Cuvette et Bidet suspendu.
Soporte para Inodoro y Bidé.

48 € 32,00

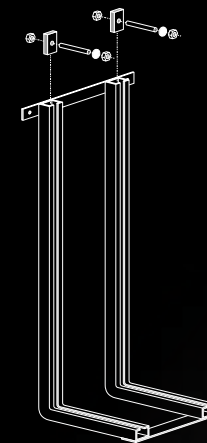

C000471



shift **Shift**

Lavabo da parete - **destro** - con ripiano
 Wall-mounted washbasin - **right** - with integrated lower shelf
 Lave main mural - à **droite** - avec un plateau inférieur.
 Wand Einbau Waschtisch - **Rechts** - mit integriertem unteren Regal.
 Lavabo mural - a la **derecha** - con la plataforma integrada inferior.

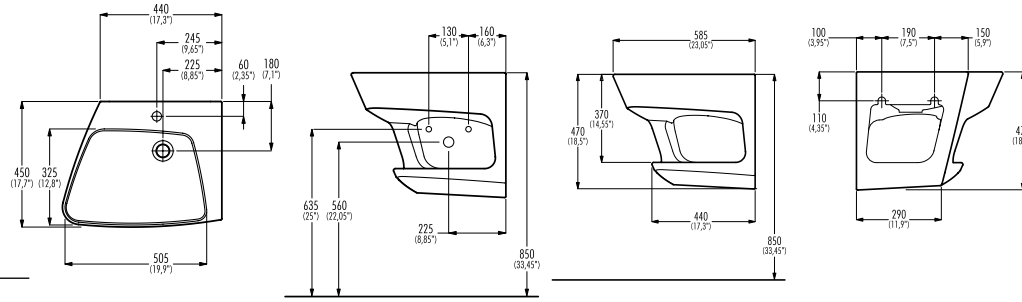

00 € 990,00

C019012

Lavabo da parete - **sinistro** - con ripiano
 Wall-mounted washbasin - **left** - with integrated lower shelf
 Lave main mural - à **gauche** - avec un plateau inférieur.
 Wand Einbau Waschtisch - **Links** - mit integriertem unteren Regal.
 Lavabo mural - **izquierdo** - con la plataforma integrada inferior

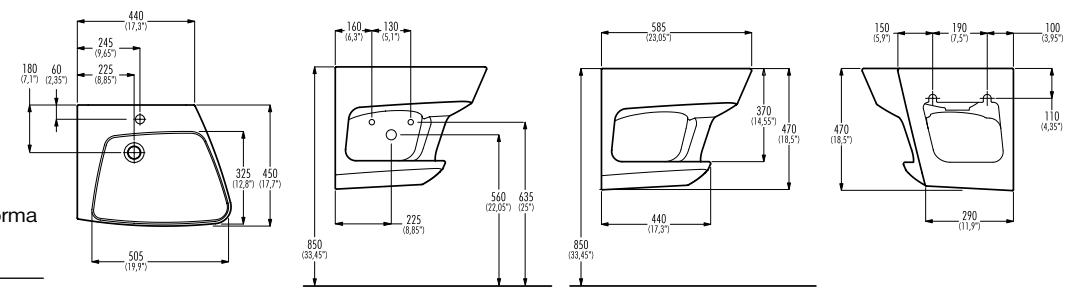

00 € 990,00

C019011



Lavabo da parete - **destro**
 Wall-mounted washbasin - **right**
 Lave main mural - **à droite**.
 Wand Einbau Waschtisch - **Rechts**.
 Lavabo mural - **a la derecha**.

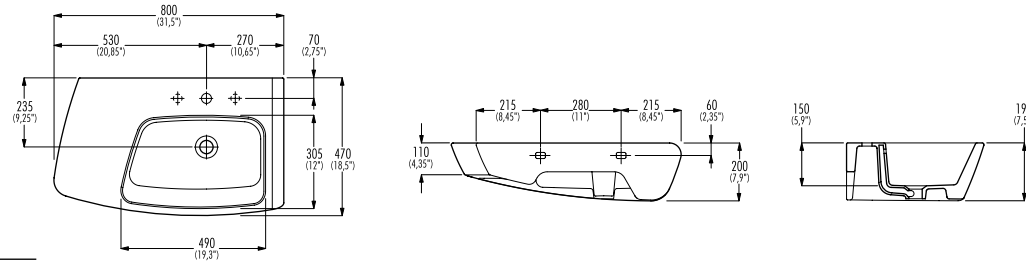

00 € 535,00

C020012

Lavabo da parete - **sinistro**
 Wall-mounted washbasin - **left**
 Lave main mural - **à gauche**.
 Wand Einbau Waschtisch - **Links**.
 Lavabo mural - **izquierdo**.

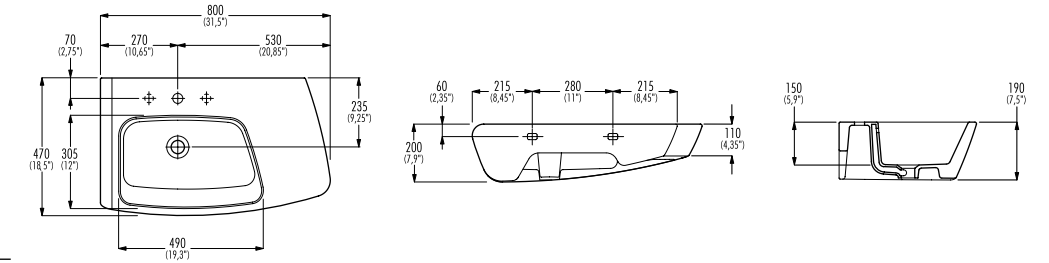

00 € 535,00

C020011



Lavabo da parete.
Wall mounted washbasin.
Lave main mural.
Wand Einbau Waschtisch.
Lavabo mural.

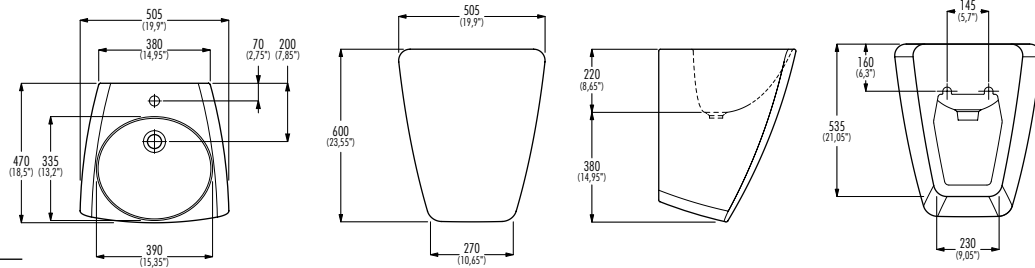

00 € 865,00

C044011

Lavabo da parete e da appoggio.
Wall/top mounted washbasin.
Lave main mural et à encastrer
Wand und Stand Waschtisch.
Lavabo mural y de apoyo.

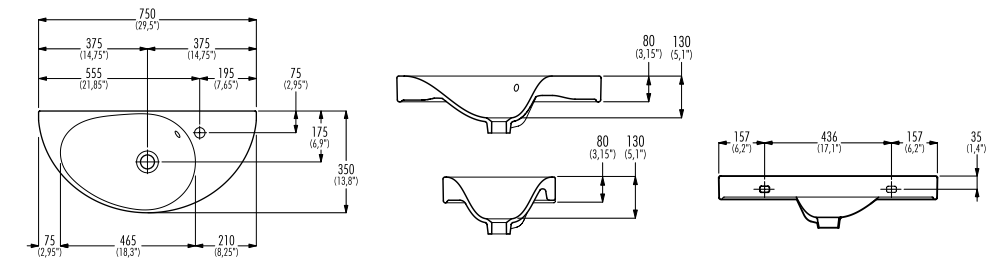

00 € 270,00

C003011

hub

blot



Lavabo da appoggio, cm 80.
 Top mounted washbasin, cm 80.
 Lavabo à encastrer, cm 80.
 Stand Waschtisch, cm 80.
 Lavabo de apoyo, cm 80

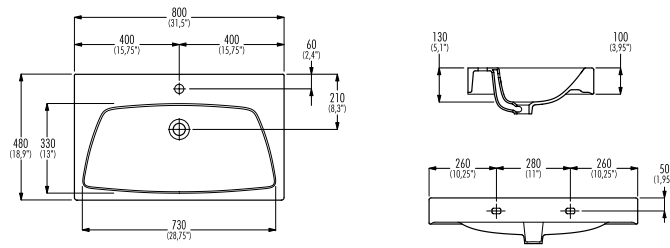

00 € 440,00

C034011

Lavabo da appoggio, cm 110.
 Top mounted washbasin, cm 110.
 Lavabo à encastrer, cm 110.
 Stand Waschtisch, cm 110.
 Lavabo de apoyo, cm 110.

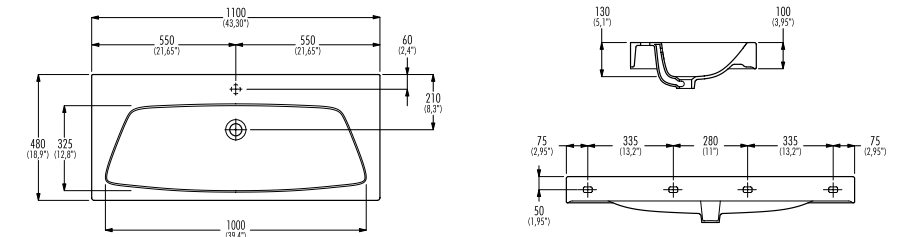

00 € 620,00

C034012



Lavabo da appoggio con copripiletta in ceramica.

Top mounted washbasin with waste ceramic cover.

Lavabo à encastrer avec la couverture du bouchon en ceramique.

Stand Waschtisch mit Keramik Ablauf Deckel.

Lavabo de apoyo, con cobertura de tapón en cerámica.

00 € 310,00

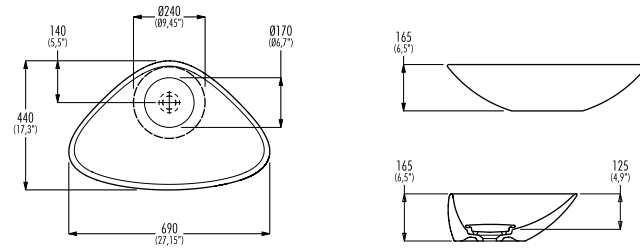

C011171

Lavabo da appoggio con copripiletta in ceramica.

Top mounted washbasin with waste ceramic cover.

Lavabo à encastrer avec la couverture du bouchon en ceramique.

Stand Waschtisch mit Keramik Ablauf Deckel.

Lavabo de apoyo, con cobertura de tapón en cerámica.

00 € 280,00

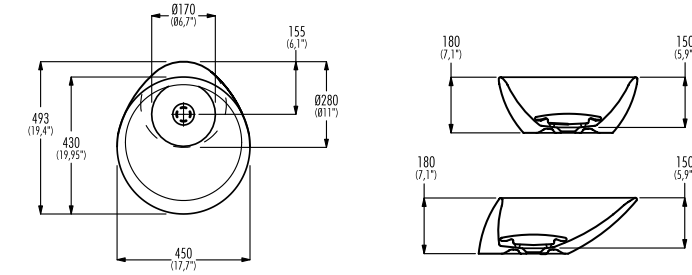

C023171

drag

net

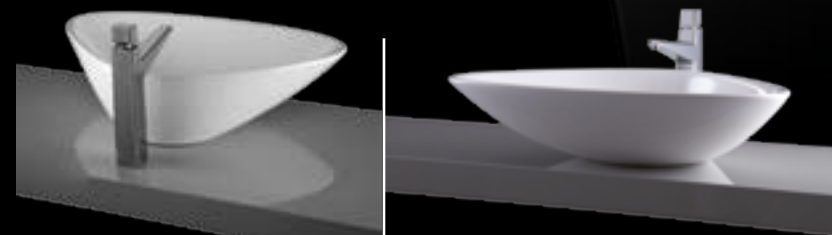

Lavabo da appoggio, cm 61.
 Top mounted washbasin, cm 61.
 Lavabo à encastrer, cm 61.
 Stand Waschtisch, cm 61.
 Lavabo de apoyo, cm 61.

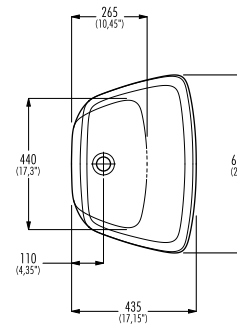
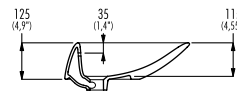

00 € 300,00

C042073

Lavabo da appoggio, cm 68.
 Top mounted washbasin, cm 68.
 Lavabo à encastrer, cm 68.
 Stand Waschtisch, cm 68.
 Lavabo de apoyo, cm 68.

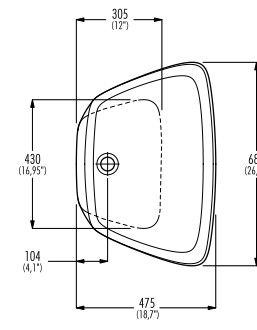
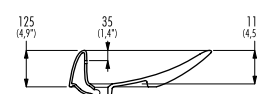

00 € 355,00

C042071

Lavabo da appoggio, cm 84.
 Top mounted washbasin, cm 84.
 Lavabo à encastrer, cm 84.
 Stand Waschtisch, cm 84.
 Lavabo de apoyo, cm 84.

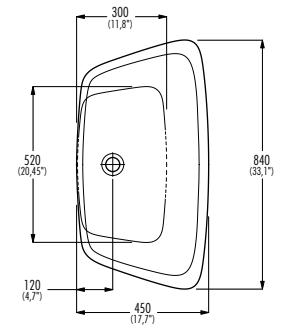
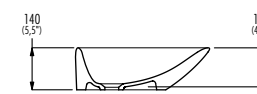

00 € 410,00

C042172



Lavabo da semi-incasso.
Semi-countertop basin.
Lave main à encastrer.
Einbau Waschtisch.
Lavabo sobremueble.

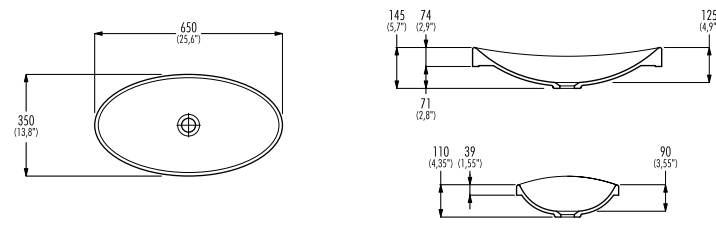

00 € 250,00

C033171

Lavabo da semi-incasso con copripiletta in ceramica.
Semi-countertop basin with waste ceramic cover.
Lave main à encastrer avec la couverture du bouchon en ceramique.
Einbau Waschtisch mit Keramik Ablauf Deckel.
Lavabo sobremueble, con cobertura de tapón en cerámica.

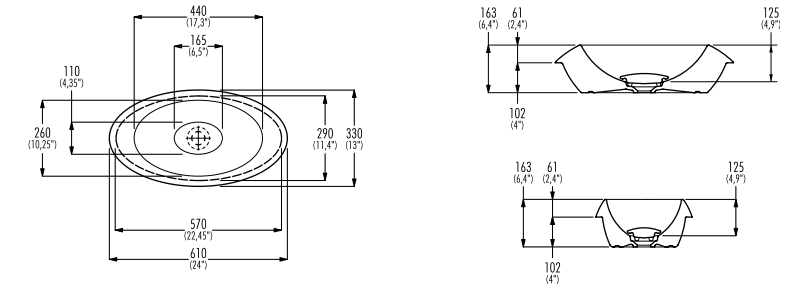

00 € 260,00

C041171

spool

zena

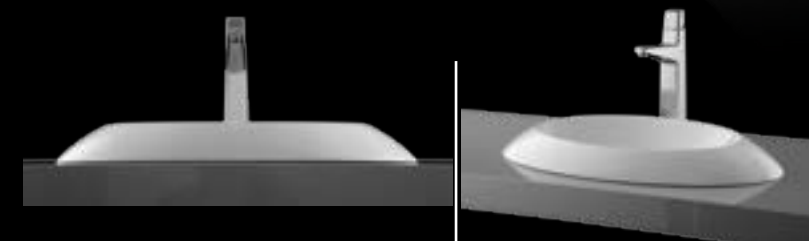

Lavabo da semi-incasso con copripiletta in ceramica.

Semi-countertop basin with waste ceramic cover.

Lave main à encastrer avec la couverture du bouchon en ceramique.

Einbau Waschtisch mit Keramik Ablauf Deckel.

Lavabo sobremueble, con cobertura de tapòn en cerámica.

00 € 365,00

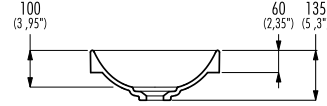
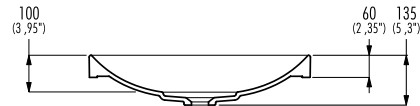
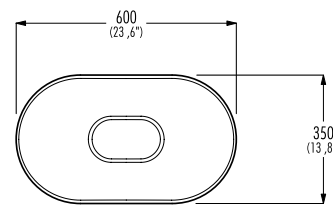

Lavabo da semi-incasso con scarico occultato.

Semi-countertop basin with hidden pop-up waste.

Lave main à encastrer avec le bouchon cache.

Stand Waschtisch mit versteckten Ablauf.

Lavabo sobremueble, con tapòn escondido.

00 € 630,00

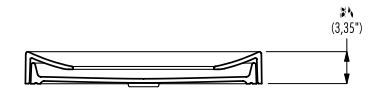
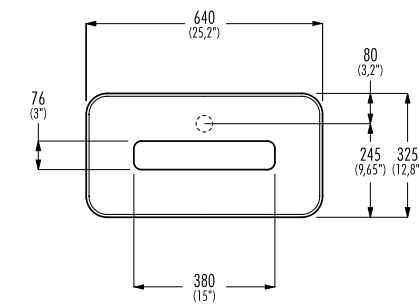

C045171

C060171

debug

tab



Lavabo sottopiano con copripiletta in ceramica.
 Under-countertop basin with waste ceramic cover.
 Lave main à encastrer par dessous avec la couverture du bouchon en ceramique.
 Unterbau Waschtisch mit Keramik Ablauf Deckel.
 Lavabo bajo encimera, con cobertura de tapón en cerámica.

00 € 290,00

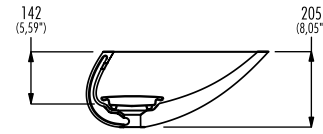
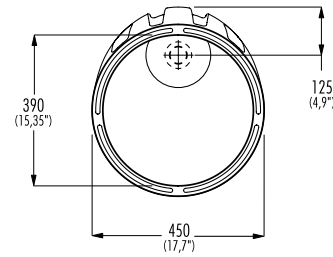

Lavabo da semi-incasso.
 Semi-countertop basin.
 Lave main à encastrer.
 Einbau Waschtisch.
 Lavabo sobremueble.

00 € 270,00

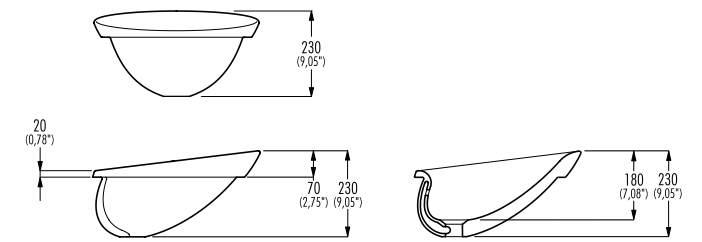
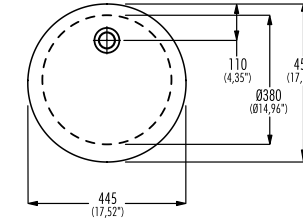

C028072

C027071

play

plug



Lavabo da appoggio.
Top mounted washbasin.
Lavabo à encastrer.
Stand Waschtisch.
Lavabo de apoyo.

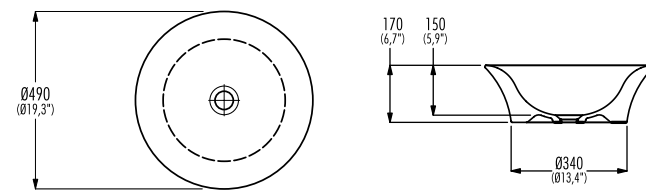

00 € 215,00

C014171

Lavabo da semi-incasso.
Semi-countertop basin.
Lave main à encastrer.
Einbau Waschtisch.
Lavabo sobremueble.

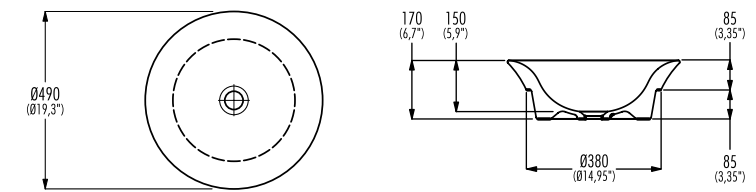

00 € 220,00

C014172



elisa

Lavabo da appoggio.
Top mounted washbasin.
Lavabo à encastrer.
Stand Waschtisch.
Lavabo de apoyo.

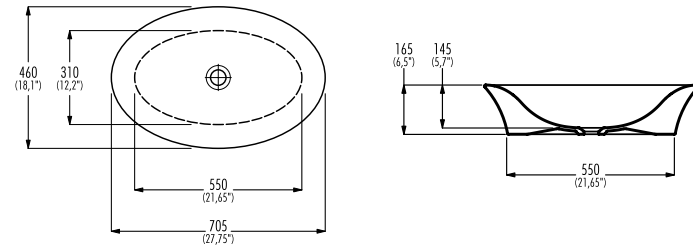

00 € 275,00

C014173

Lavabo da semi-incasso.
Semi-countertop basin.
Lave main à encastrer.
Einbau Waschtisch.
Lavabo sobremueble.

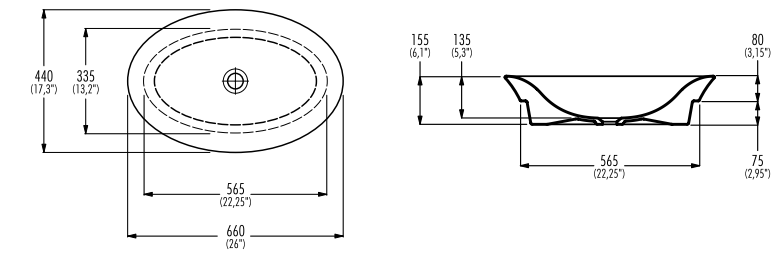

00 € 270,00

C014175



elisa ovale

docce saliscendi accessori e ricambi



composit

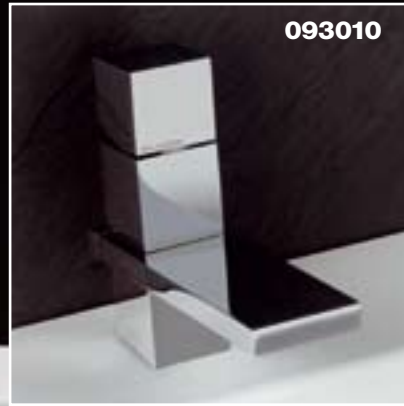

Soffione doccia Trendyclean in ABS, ø 200 mm.
 Trendyclean ABS headshower, ø 200 mm
 Pomme de douche Trendyclean en ABS ø 200 mm.
 Trendyclean ABS Kopfdusche ø 200 mm.
 Rociador Trendyclean en ABS, ø 200 mm.

Soffione doccia Trendyclean in ottone, ø 200 mm.
 Trendyclean brass headshower, ø 200 mm
 Pomme de douche Trendyclean en laiton, ø 200 mm.
 Trendyclean Messing Kopfdusche ø 200 mm.
 Rociador Trendyclean en latón, ø 200 mm.

l/m	15	22	31	37	43
Kg/cm ²	0,5	1	2	3	4
10 € 109,00					

l/m	15	22	31	37	43
Kg/cm ²	0,5	1	2	3	4
10 € 189,00					

992686



992610



Soffione doccia Kubik-Clean in ABS.
 Kubik-Clean ABS shower rose.
 Tête de douche Kubik-Clean en ABS.
 Kubik-Clean ABS Kopfdusche.
 Rociador Kubik-Clean en ABS.

Soffione doccia Kubik-Clean in ottone.
 Kubik-Clean brass shower rose.
 Tête de douche Kubik-Clean en laiton.
 Kubik-Clean Messing Kopfdusche.
 Rociador Kubik-Clean en latón.

l/m ²	16	23	31	37	41
kg/cm ²	0,5	1	2	3	4
10 € 144,00					

l/m ²	16	23	31	37	41
kg/cm ²	0,5	1	2	3	4
10 € 224,00					

992687



992636



Soffione doccia Trendyclean in ABS, ø 200 mm, braccio orizzontale in ottone 300 mm
 Trendyclean ABS headshower, ø 200 mm, horizontal 300 mm brass arm.
 Pomme de douche Trendyclean en ABS ø 200 mm, bras horizontale en laiton de 300 mm.
 Trendyclean ABS Kopfdusche ø 200 mm mit Waagerechtem Messing Arm 300 mm.
 Rociador Trendyclean en ABS, ø 200 mm con brazo horizontal 300 mm en latón.

Soffione doccia Trendyclean in ottone, ø 200 mm, braccio orizzontale in ottone 300 mm
 Trendyclean brass headshower, ø 200 mm, horizontal 300 mm brass arm.
 Pomme de douche Trendyclean en laiton ø 200 mm, bras horizontale en laiton de 300 mm.
 Trendyclean Messing Kopfdusche ø 200 mm mit Waagerechtem Messing Arm 300 mm.
 Rociador Trendyclean en latón, ø 200 mm con brazo horizontal 300 mm en latón.

l/m	15	22	31	37	43
Kg/cm ²	0,5	1	2	3	4
10 € 139,00					

l/m	15	22	31	37	43
Kg/cm ²	0,5	1	2	3	4
10 € 219,00					

992675



992627



Soffione doccia Kubik-Clean in ABS con braccio 300 mm.
 Kubik-Clean ABS shower rose with 300 mm arm.
 Tête de douche Kubik-Clean en ABS avec bras de 300 mm.
 Kubik-Clean ABS Kopfdusche mit 300 mm Arm.
 Rociador Kubik-Clean con brazo de 300 mm en ABS.

Soffione doccia Kubik-Clean in ottone con braccio 300 mm.
 Kubik-Clean brass shower rose with 300 mm arm.
 Tête de douche Kubik-Clean en laiton avec bras de 300 mm.
 Kubik-Clean Messing Kopfdusche mit 300 mm Arm.
 Rociador Kubik-Clean en latón con brazo de 300 mm.

l/m ²	16	23	31	37	41
kg/cm ²	0,5	1	2	3	4
10 € 174,00					

l/m ²	16	23	31	37	41
kg/cm ²	0,5	1	2	3	4
10 € 254,00					

992688



992640



doccia accessori

Soffione Trendyclean in ABS con raccordo verticale da soffitto in ottone.
 Treandyclean ABS headshower with vertical brass arm, ceiling installation.
 Pomme de douche Trendyclean en ABS avec bras vertical en laiton, montage plafond.
 Trendyclean ABS Kopfdusche mit senkrechtem Anschluss, Decke Montage.
 Rociador Trendyclean en ABS con brazo vertical en latón.

Doccetta Slim-rain in ABS.
 Slim-rain ABS Handshower.
 Douchette Slim-rain en ABS.
 Slim-rain ABS Handbrause.
 Ducha Slim-rain en ABS.

Asta doccia ø 18 mm doccetta ABS e flessibile.
 Slide rail ø 18 mm with flexible tube and ABS handshower.
 Barre de douche ø 18 mm avec flexible et douchette en ABS.
 Dusche Stange ø 18 mm mit ABS Brause und Brauseschlauch.
 Barra ducha deslizante ø 18 mm ducha en ABS y flexible.

Asta doccia ø 18 mm doccetta 5 getti e flessibile.
 Slide rail ø 18 mm with flexible tube and 5 jets spray handshower.
 Barre de douche ø 18 mm avec flexible et douchette 5 jets.
 Dusche Stange ø 18 mm mit 5-Strahl-Handbrause und Brauseschlauch.
 Barra ducha deslizante ø 18 mm ducha 5 chorros y flexible.

Asta doccia con doccetta Slim-rain e flessibile Gliss 1,5 m.
 Slide rail with flexible tube Gliss 1,5 m and Slim-rain handshower.
 Barre de douche avec flexible 1,5 m Gliss et douchette Slim-rain.
 Dusche Stange mit Slim-rain Brause und Gliss Brauseschlauch 1,5 m.
 Barra ducha con ducha Slim-rain y flexible Gliss 1,5 m.

Asta doccia quadrata con doccetta Slim-rain e flessibile Gliss 1,5 m.
 Slide rail with flexible tube Gliss 1,5 m and Slim-rain handshower.
 Barre de douche avec flexible 1,5 m Gliss et douchette Slim-rain.
 Eckige Dusche Stange mit Slim-rain Brause und Gliss Brauseschlauch 1,5 m.
 Barra ducha cuadrada con ducha Slim-rain y flexible Gliss 1,5 m.

l/m	15	22	31	37	43
Kg/cm ²	0,5	s1	2	3	4
10 € 159,00					

l/m ¹	16	23	31	37	41
kg/cm ²	0,5	1	2	3	4
10 € 20,00					

l/m	9	13	18	23	26
Kg/cm ²	0,5	1	2	3	4
10 € 74,90					

l/m	9	13	18	23	26
Kg/cm ²	0,5	1	2	3	4
10 € 86,90					

l/m ¹	9	13	18	23	26
kg/cm ²	0,5	1	2	3	4
10 € 240,00					

l/m ¹	9	13	18	23	26
kg/cm ²	0,5	1	2	3	4
10 € 329,50					

992676



991205



992080



992081



992078



992077



doccia accessori

Coppia di rubinetti sottolavabo con filtro disconnettore, 1/2 x 10 mm.
 Pair of square valve 1/2 x 10 mm under basin-with disconnecting filter.
 Pair of robinets d'equerre 1/2 x 10 mm sous-lavabo avec filtre disconnecteur.
 Satz von zwei Eckventile 1/2 x 10 mm mit automatische Absperrungsfiler.
 Dos grifos a angulo con filtro disconnector 1/2 x 10 mm.

10 € 75,00

Sifone per lavabo tondo.
 Washbasin round trap.
 Syphon de lavabo rond.
 Syphon für Waschtisch, Rund.
 Sifòn para lavabo redondo.

10 € 65,00

Sifone per lavabo quadro.
 Washbasin square trap.
 Syphon de lavabo carré.
 Syphon für Waschtisch, Quadratisch.
 Sifòn para lavabo cuadrado.

10 € 210,00

Sifone per bidet tondo.
 Bidet round trap.
 Syphon de bidet rond.
 Syphon für Bidet, Rund.
 Sifòn para bidet redondo.

10 € 65,00

Sifone per bidet quadro.
 Bidet square trap.
 Syphon de bidet carré.
 Syphon für Bidet, Quadratisch.
 Sifòn para bidet cuadrado.

10 € 210,00

Coppia di tubetti rame per monoforo e monocomando.
 Pair of tuayeau en cuivre pour monotrou et monocommande.
 2 Kupferröhre.
 Dos tubos en cobre de alimentacion monoforo.

10 € 9,00

126221



991443



991453



991444

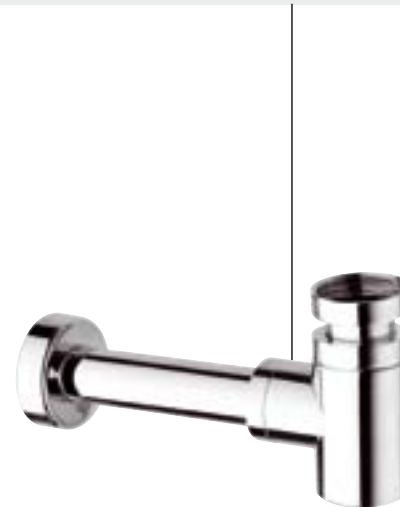

991454



991830



Flessibile di alimentazione M 10x1 con dado 3/8" F, attacco corto, 45 cm.
 Inlet flexible tube M 10x1 with nut 3/8" F, short connection, 45 cm.
 Tube d'alimentation flexible M 10x1 avec ecrou 3/8" F, raccord court, 45 cm.
 Flexible Schlauch M 10x1 mit x Mutter 3/8", kurz Anschlüss, 45 cm.
 Flexible d'alimentacion M 10x1 con dado 3/8 F, 45 cm.

blue 97 € 4,50 red 98 € 4,50

Scarico automatico 1" 1/4, Click-Clack.
 Pop-up waste 1" 1/4, Click-Clack.
 Vidage automatique 1"1/4, Click-Clack.
 Ablaufgarnitur 1"1/4, Click-Clack.
 Desague automatico 1" 1/4, Click-Clack.

10 € 35,00

Scarico automatico 1" 1/4 con tappo copripiletta.
 Pop-up waste 1" 1/4 total covering plug.
 Vidage automatique 1"1/4 bouchon à couverture totale.
 Ablaufgarnitur 1"1/4 komplett deckender Ablaufteller.
 Desague automatico 1" 1/4 con tapòn a cobertura total.

10 € 30,00

Scarico automatico 1" 1/4 con tappo in ottone.
 Pop-up waste 1" 1/4 brass plug.
 Vidage automatique 1"1/4 bouchon en laiton.
 Ablaufgarnitur 1"1/4 mit Messing Ablaufteller.
 Desague automatico 1" 1/4 con tapòn en latòn.

10 € 17,50

Scarico libero.
 Pop-up waste.
 Bonde de vidage.
 Ablaufgarnitur.
 Desagüe libre.

10 € 35,00

Scarico libero senza tappo.
 Waste without pop-up.
 Bonde de vidage sans bouchon.
 Ablauf ohne Ablaufteller.
 Desagüe libre sin tapòn.

10 € 20,00

991855

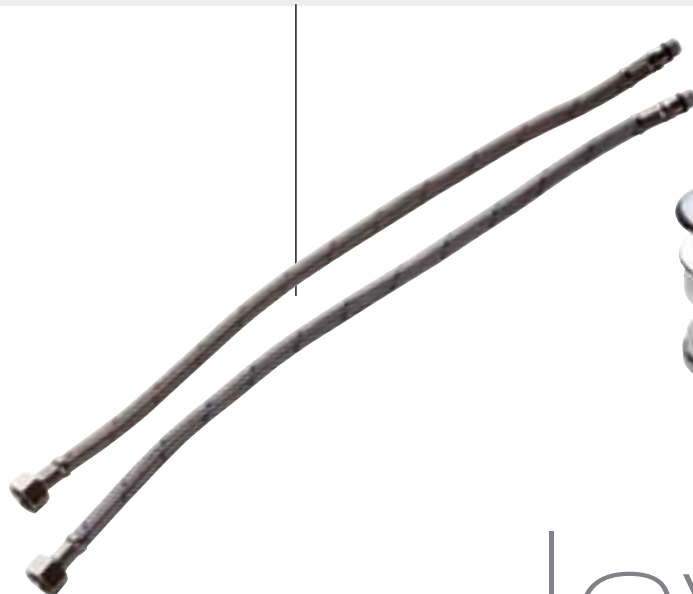

991449



991412



991410



991403



991457



lavabo accessori

Raccordo da incasso per alimentazione flessibile.
 Connection to flexible for concealed installation.
 Raccord pour flexible pour installations à encastrer.
 Anschluss für Brauseschlauch.
 Connexion para tubo flexible.

Track - Raccordo da incasso per alimentazione flessibile.
 Track - Connection to flexible for concealed installation.
 Track - Raccord pour flexible pour installations à encastrer.
 Track - Anschluss für Brauseschlauch.
 Track - Connexion para tubo flexible.

Click - Supporto orientabile per doccia.
 Click - Swivel wall bracket for shower.
 Click - Support orientable pour douche.
 Click - verstellbarer Brausehalter.
 Click - Soporte orientable para ducha.

Track - Supporto orientabile per doccia.
 Track - Swivel wall bracket for shower.
 Track - Support orientable pour douche.
 Track - verstellbarer Brausehalter.
 Track - Soporte orientable para ducha.

Supporto fisso per doccia.
 Fixed wall bracket for shower.
 Support fixe pour douche.
 Fix Brausehalter.
 Soporte fijo para ducha.

Supporto orientabile per doccia.
 Swivel bracket for shower.
 Support orientable pour douche.
 Schwenkbarer Brausehalter.
 Soporte orientable para ducha.

10 € 29,50

10 € 49,00

10 € 118,00

10 € 118,00

10 € 39,50

10 € 15,00

991054



991046

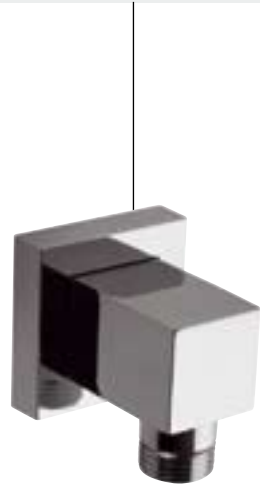

991083



991044



991045



991031



Supporto fisso per doccia.
 Fixed wall bracket for shower.
 Support fixe pour douche.
 Fix Brausehalter.
 Soporte fijo para ducha.

Flessibile a maglia doppia m 1,5 1/2" x 1/2".
 Flexible tube, double fastening, m 1,5 1/2" x 1/2".
 Tube flexible, double maille, m 1,5 1/2" x 1/2".
 Brauseschlauch, agraff, m 1,5, 1/2" x 1/2".
 Tubo flexible, doble grapado m 1,5 1/2" x 1/2".

Flessibile Gliss m 1,5, 1/2" x 1/2".
 Gliss flexible tube m 1,5, 1/2" x 1/2".
 Tube flexible Gliss m 1,5, 1/2" x 1/2".
 Gliss Brauseschlauch m 1,5, 1/2" x 1/2".
 Flexible Gliss m 1,5, 1/2" x 1/2".

Soffioncino laterale anticalcare con attacco da 1/2, raccordo maschio.
 Self-cleaning body spray, 1/2" male connection.
 Douche latérale anticalcaire raccord 1/2" mâle.
 Antikalk Seitenbrause mit 1/2" M - Anschluss.
 Ducha lateral anticalcarea con connexion 1/2" M.

Soffioncino laterale con attacco da 1/2, raccordo maschio.
 Body spray, 1/2" male connection.
 Douche latérale raccord 1/2" mâle.
 Seitenbrause mit 1/2" M - Anschluss.
 Ducha lateral con connexion 1/2" M.

Bocca vasca murale.
 Wall mounted spout for bath-tub.
 Bec mural pour baignoire.
 Wand-Wanneneinlauf.
 Caño para bañera.

10 € 5,0

10 € 10,00

10 € 15,00

10 € 43,50

10 € 35,00

10 € 85,50

991085



991006



991007



992652

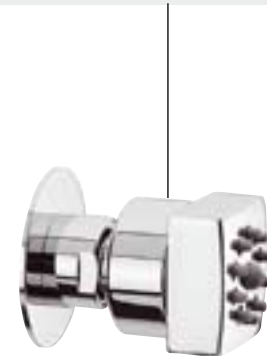

992648

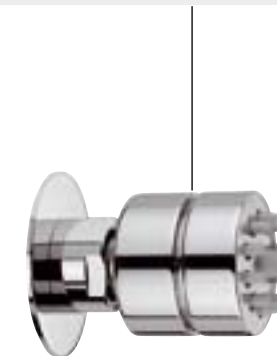

9921D1



doccia accessori

Piastra quadra per incasso doccia e deviatore a due ed a tre vie per serie Track.

Cover plate for Track serie concealed 2 and 3 ways diverter. Plaque pour inverseur à encastrer à 2 et à 3 voies série Track.

Abdeckplatte für 2 und 3 Wege Unterputz Umsteller für Serie Track.

Placa para mezclador de desviador 2 y 3 vias empotrado serie Track.

10 € 90,00

991615



Piastra per incasso doccia con deviatore per serie Track.

Cover plate for Track serie, concealed mixer with diverter. Plaque pour mitigeur à encastrer avec inverseur série Track.

Abdeckplatte für Unterputz mit Umsteller für Serie Track.

Placa para mezclador de ducha empotrado con desviador serie Track.

10 € 110,00

991620



Piastra per miscelatore con deviatore programma "Buongiorno".

Cover plate for mixer with diverter, programme "Buongiorno". Plaque pour mitigeur avec inverseur, programme "Buongiorno".

Abdeckplatte für Mischer mit Umsteller für "Buongiorno" Artikel.

Placa para mezclador con distribuidor, programa "Buongiorno".

10 € 110,00

991625



Piastra per miscelatore termostatico da incasso per articoli: 412410, 412414, 412425, 412426.

Cover plate for concealed thermostatic mixer for: 412410, 412414, 412425, 412426.

Plaque pour mitigeur thermostatique à encastrer pour: 412410, 412414, 412425, 412426.

Abdeckplatte für Thermostat Mischer mit Umsteller für: 412410, 412414, 412425, 412426.

Placa para mezclador termostático empotrado para: 412410, 412414, 412425, 412426.

10 € 110,00

991645



Piastra quadra per incasso doccia e deviatore a due ed a tre vie per serie Click.

Cover plate for Click serie concealed 2 and 3 ways diverter. Plaque pour inverseur à encastrer à 2 et à 3 voies série Click.

Abdeckplatte für 2 und 3 Weg Unterputz Umsteller für Serie Click.

Placa para mezclador de desviador 2 y 3 vias empotrado serie Click.

10 € 90,00

991650



Piastra per incasso doccia con deviatore per serie Click.

Cover plate for Click serie, concealed mixer with diverter. Plaque pour mitigeur à encastrer avec inverseur série Click.

Abdeckplatte für Unterputz mit Umsteller für Serie Click.

Placa para mezclador de ducha empotrado con desviador serie Click.

10 € 110,00

991653



Piastra per miscelatore con deviatore programma "Buongiorno".

Cover plate for mixer with diverter, programme "Buongiorno". Plaque pour mitigeur avec inverseur, programme "Buongiorno".

Abdeckplatte für Mischer mit Umsteller für "Buongiorno" Artikel.

Placa para mezclador con desviador, programa "Buongiorno".

10 € 110,00

991651



Piastra per miscelatore termostatico da incasso per articoli: 212410, 212414, 212425, 212426.

Cover plate for concealed thermostatic mixer for: 212410, 212414, 212425, 212426.

Plaque pour mitigeur thermostatique à encastrer pour: 212410, 212414, 212425, 212426.

Abdeckplatte für Mischer mit Umsteller für: 212410, 212414, 212425, 212426.

Placa para mezclador termostático empotrado para: 212410, 212414, 212425, 212426.

10 € 110,00

991652



Asta di scarico per serie Click. Rod for pop-up waste for Click series.

Tige de vidage pour série Click. Ablaufstange für Serie Click. Asta de desagüe para serie Click.

10 € 19,50

992477



Asta di scarico per serie Track. Rod for pop-up waste for Track series.

Tige de vidage pour série Track. Ablaufstange für Serie Track. Asta de desagüe para serie Track.

10 € 25,50

992478



Asta di scarico per serie Mis. Rod for pop-up waste for Mis series.

Tige de vidage pour série Mis. Ablaufstange für Serie Mis. Asta de desagüe para serie Mis.

10 € 17,50

992479



Aeratore per lavabo Click. Click washbasin aerator.

Aérateur pour mitigeur de lavabo serie Click. Click Luftsprudler für Waschtisch. Aireador para lavabo Click.

10 € 7,25

990051



Aeratore per lavabo con bocca prolungata, Click.

Click extended spout washbasin aerator. Aérateur pour mitigeur de lavabo bec 175 mm. serie Click. Click Luftsprudler für Waschtisch, Auslauf 175 mm.

Aireador para lavabo caño prolongado, Click.

10 € 7,25

990052



Aeratore cascata Track. Track aerator.

Aérateur serie Track. Track Luftsprudler. Aireador Track.

10 € 14,50

990053



Aeratore Slim per lavabo Mis. Mis, Slim washbasin aerator.

Aérateur Slim pour mitigeur de lavabo serie Mis. Mis, Slim Luftsprudler für Waschtisch.

Aireador Slim para lavabo Mis.

10 € 5,25

990054



Aeratore con snodo per bidet serie Click, Track e Mis.

Click, Track e Mis. aerator with swivel connection for bidet, Aérateur avec rotule pour bidet, serie Click, Track e Mis.

Click, Track und Mis Luftsprudler mit Kugelgelenk für Bidet.

Aireador móvil para bidet, serie Click, Track e Mis.

10 € 12,50

990055



Cartuccia ø 25 mm.
Cartridge ø 25 mm.
Cartouche ø 25 mm.
Kartusche ø 25 mm.
Cartucho ø 25 mm.

Cartuccia senza distributore ø 35 mm.
Cartridge without distributor ø 35 mm.
Cartouche sans distributeur ø 35 mm.
Kartusche ohne Wasserleitung ø 35 mm.
Cartucho ø 35 mm. sin distribuidor.

Cartuccia senza distributore ø 40 mm.
Cartridge without distributor ø 40 mm.
Cartouche sans distributeur ø 40 mm.
Kartusche ohne Wasserleitung ø 40 mm.
Cartucho ø 40 mm. sin distribuidor.

Cartuccia deviatore 4/5 vie, programma "Buongiorno".
4/5 ways diverter cartridge for "Buongiorno" programme.
Cartouche pour inverseur à encastrer à 4/5 voies, programme "Buongiorno".
Kartusche für Unterputz 4/5 weg Umsteller, "Buongiorno" Artikel.
Cartucho distribuidor empotrable 4/5 salidas, programa "Buongiorno"

Cartuccia deviatore 3 vie, programma "Buongiorno".
3 ways diverter cartridge for "Buongiorno" programme.
Cartouche pour inverseur à encastrer à 3 voies, programme "Buongiorno".
Kartusche für Unterputz 3 weg Umsteller, "Buongiorno" Artikel.
Cartucho distribuidor empotrable 3 salidas, programa "Buongiorno"

Cartuccia deviatore 2 vie, programma "Buongiorno".
2 ways diverter cartridge for "Buongiorno" programme.
Cartouche pour inverseur à encastrer à 2 voies, programme "Buongiorno".
Kartusche für Unterputz 2 weg Umsteller, "Buongiorno" Artikel.
Cartucho distribuidor empotrable 2 salidas, programa "Buongiorno"

Cartuccia termostatica G 1/2".
Thermostatic cartridge G 1/2".
Cartouche Thermostatique G 1/2".
Thermostat Kartusche G 1/2".
Cartucho termostático G 1/2".

Cartuccia termostatica G 3/4".
Thermostatic cartridge G 3/4".
Cartouche Thermostatique G 3/4".
Thermostat Kartusche G 3/4".
Cartucho termostático G 3/4".

99 € 30,50

99 € 22,50

99 € 23,50

99 € 55,00

99 € 55,00

99 € 48,00

99 € 75,00

99 € 79,00

990253



990251



990220



990261



990262



990263



990247



990252



Coprihiera per serie Click e Mis.
Cartridge cover for Click e Mis series.
Frette pour séries Click e Mis.
Kartusche Rosette für Click e Mis.
Cubre fijador para serie Click e Mis.

Ghiera fermacartuccia per lavabo Track.
Fixing lock ring for wash basin Track.
Ecrou de fixation pour lavabo Track.
Kartuschesicherungsring für Waschtisch Track.
Fijador para cartucho para lavabo Track.

Coprihiera per lavabo Track.
Cartridge cover for wash basin, Track serie.
Frette pour lavabo série Track.
Kartusche Rosette für Waschtisch Track.
Cubre fijador para lavabo serie Track.

Ghiera fermacartuccia per vasca/doccia Track.
Fixing lock ring for Track bath/shower.
Ecrou de fixation pour bain/douche Track.
Kartuschesicherungsring für Track Wanne-Brause.
Fijador para cartucho para baño/ducha Track.

Coprihiera per vasca/doccia Track.
Cartridge cover for Track bath/shower.
Frette pour bain-douche Track.
Kartusche Rosette für Track Wanne-Brause.
Fijador para cartucho para baño/ducha Track.

Kit fissaggio per lavabo Click.
Click fixing kit for single hole mixer.
Jeu de fixation de monotrous pour Click.
Click Befestigungssatz für Einlochbatterie.
Kit de fijación para lavabo Click.

Kit fissaggio Mis con basetta.
Mis fixing kit with base ring.
Jeu de fixation pour Mis avec bague de bas.
Mis Befestigungssatz für Einlochbatterie mit Messing Ring.
Kit de fijación Mis con anillo de base.

10 € 6,50

10 € 5,00

10 € 7,50

02 € 5,00

10 € 7,50

99 € 5,00

99 € 14,00

992357



992358



992359



992307



992308



992215



992274



Kit fissaggio per lavabo Track.
Track fixing kit for single hole mixer.
Jeu de fixation de monotrous pour Track.
Track Befestigungssatz für Einlochbatterie.
Kit de fijacion para lavabo Track.

Basetta in ottone per miscelatore serie Track.
Brass ring for Track serie.
Embase en laiton pour serie Track.
Messing Ring für Track.
Anillo de base en latón serie Track.

Maniglia Click.
Click handle.
Lever Click.
Click Hebel.
Maneta Click.

Maniglia per miscelatore incasso doccia, Click.
Click handle for concealed mixer.
Lever pour mitigeur monocommande à encastrer, Click.
Click Hebel für Unterputz Brausebatterie.
Maneta para mezclador empotrado, Click.

Maniglia per cartuccia deviatore 2-3-4-5 uscite, Click.
Click handle for 2-3-4-5 ways diverter cartridge.
Lever pour cartouche inverseur à encastrer à 2-3-4-5 voies, Click.
Click Hebel für Keramische Kartusche für Unterputz 2-3-4-5 Ausgänge.
Maneta para cartucho distribuidor empotrable 2-3-4-5 salidas, Click.

Maniglia per miscelatore termostatico da incasso, Click.
Click handle for concealed thermostatic mixer.
Lever pour mitigeur thermostatique à encastrer, Click.
Click Hebel für Unterputz Thermostat-Mischer.
Maneta para mezclador termostático empotrado, Click.

Maniglia per deviatore rubinetto da incasso, Click.
Click handle for concealed diverters.
Lever pour inverseur à encastrer, Click.
Click Hebel für Unterputz Absperventil.
Maneta para distribuidor empotrable, Click.

99 € 5,00

99 € 18,00

10 € 50,00

10 € 50,00

10 € 50,00

10 € 63,00

10 € 50,00

992211



992367



993019



9930L4



9930L5



9930L6



9930L7



Maniglia Track.
Track handle.
Lever Track.
Track Hebel.
Maneta Track.

Maniglia per miscelatore incasso doccia, Track.
Track handle for concealed mixer.
Lever pour mitigeur monocommande à encastrer, Track.
Track Hebel für Unterputz Brausebatterie.
Maneta para mezclador empotrado, Track.

Maniglia per miscelatore vasca e doccia esterno, Track.
Track handle for wall mounted bath or shower mixer.
Lever pour mitigeur monocommande mural de bain ou douch, Track.
Track Hebel für Wannenfällbatterie und Brausebatterie.
Maneta para mezclador para ducha, Track.

Maniglia per cartuccia deviatore 2-3-4-5 uscite, Track.
Track handle for 2-3-4-5 ways diverter cartridge.
Lever pour cartouche inverseur à encastrer à 2-3-4-5 voies, Track.
Track Hebel für Keramische Kartusche für Unterputz 2-3-4-5 Ausgänge.
Maneta para cartucho distribuidor empotrable 2-3-4-5 salidas, Track.

Maniglia per miscelatore termostatico da incasso, Track.
Track handle for concealed thermostatic mixer.
Lever pour mitigeur thermostatique à encastrer, Track.
Track Hebel für Unterputz Thermostat-Mischer.
Maneta para mezclador termostático empotrado, Track.

Maniglia per deviatore rubinetto da incasso, Track.
Track handle for concealed diverter.
Lever pour inverseur à encastrer, Track.
Track Hebel für Unterputz Absperventil.
Maneta para distribuidor empotrable, Track.

Maniglia Mis.
Mis handle.
Lever Mis.
Mis Hebel.
Maneta Mis.

Maniglia per miscelatore incasso doccia, Mis.
Mis handle for concealed mixer.
Lever pour mitigeur monocommande à encastrer, Mis.
Mis Hebel für Unterputz Brausebatterie.
Maneta para mezclador empotrado, Mis.

10 € 55,00

10 € 55,00

10 € 55,00

10 € 55,00

10 € 68,00

10 € 55,00

10 € 40,00

10 € 40,00

9930L0



9930L1



9930L2



9930L3



9930L8



9930L9



9930M0



9930M1





Palazzani the company

High quality
sanitary fittings
since 1960



PALAZZANI



the company
azienda



PALAZZANI

future exhibition

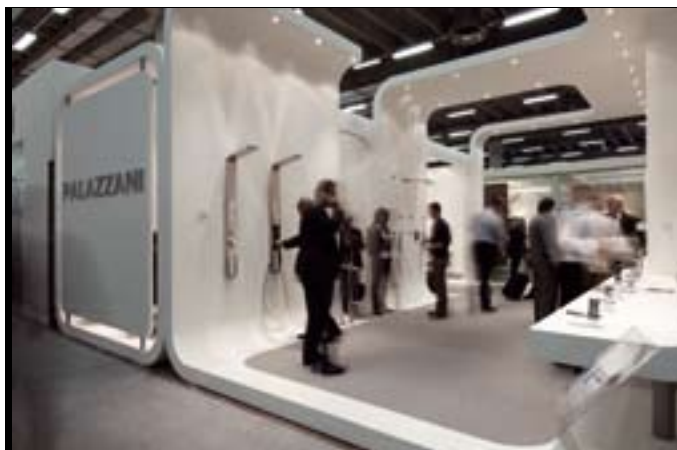

**Mostra Convegno
ExpoBagno - Milano**

**I Saloni /
Salone Internazionale
del Mobile /
Salone Internazionale
del Bagno - Milano**

Cersaie - Bologna

ISH - Frankfurt



the company
azienda

- Concept
- Design
- Research
- Development
- Engineering
- Flexibility
- and Quality



plavisdesign



the company
azienda



plavisdesign

codice	€	pag
00E101 10	334,00	114
00E102 10	269,00	114
00E103 10	304,00	115
00E104 10	239,00	115
00E621 10	375,00	126
00E629 10	365,00	127
00S101 10	284,00	116
00S102 10	254,00	116
011013 10	358,00	61
011384 10	498,00	61
06E501 10	424,00	117
06E502 10	359,00	117
06E505 10	380,00	118
06E506 10	315,00	118
06E507 10	350,00	119
06E508 10	285,00	119
06E537 10	494,00	123
06E538 10	429,00	123
06E539 10	455,50	120
06E540 10	390,50	120
06T501 10	118,00	128
06T502 10	105,00	128
06T503 10	88,00	129
06T504 10	75,00	129
06T505 10	88,00	129
06T506 10	75,00	129
091012 10	530,00	16
091015 10	415,00	17
091020 10	255,00	20
091021 10	160,00	20
091025 10	455,00	16
092010 10	165,00	21
092011 10	128,50	21
092020 10	410,00	18
092026 10	295,00	18
092027 10	335,00	18
092030 10	165,00	19
092031 10	204,00	19
092038 10	217,00	19
092039 10	217,00	19
092062 10	310,00	22
092063 10	349,00	22

codice	€	pag
092064 10	362,00	23
092065 10	362,00	23
092132 10	189,00	24
092133 10	189,00	24
092134 10	189,00	25
092135 10	189,00	25
092910 10	165,00	21
093010 10	245,00	10
093011 10	224,00	10
093018 10	295,00	13
093077 10	330,00	13
093079 10	390,00	14
093080 10	355,00	14
093085 10	265,00	11
093086 10	230,00	11
093087 10	285,00	12
093088 10	250,00	12
094010 10	259,00	15
094011 10	238,00	15
095337 10	255,00	152
095338 10	265,00	152
095339 10	305,00	152
101010 10	202,00	76
101012 10	212,00	76
101015 10	172,00	77
101022 10	145,00	79
102012 10	75,00	78
102015 10	115,00	78
102020 10	155,00	78
103010 10	99,00	72
103011 10	89,00	72
103018 10	170,00	74
103038 10	107,00	73
103045 10	97,00	73
103077 10	205,00	74
104010 10	101,00	75
104011 10	91,00	75
105337 10	240,00	151
105338 10	250,00	151
105339 10	290,00	151
105344 10	395,00	150
121089 10	360,00	77

codice	€	pag
122125 10	564,00	145
122507 10	1.695,00	137
122509 10	1.670,00	134
122511 10	1.415,00	134
122513 10	1.569,00	138
122515 10	1.899,00	140
122518 10	1.290,00	139
122520 10	1.520,00	141
122521 10	915,00	136
123063 10	169,00	73
123114 10	155,00	72
124043 10	171,00	75
125317 10	145,00	153
125326 10	144,00	153
126221 10	75,00	192
12E551 10	450,00	124
12E552 10	385,00	124
12E553 10	420,00	125
12E554 10	355,00	125
12E555 10	411,50	121
12E556 10	346,50	121
12E557 10	381,50	122
12E558 10	316,50	122
12E624 10	449,00	126
12E627 10	439,00	127
132508 10	1.750,00	135
132510 10	1.495,00	135
132512 10	1.649,00	138
132517 10	1.370,00	139
212410 10	369,00	48
212414 10	389,00	48
212425 10	409,00	48
212426 10	429,00	49
212427 10	484,00	49
212428 10	489,00	49
212500 10	209,00	50
212501 10	209,00	50
212502 10	209,00	50
212503 10	209,00	51
212504 10	209,00	51
212505 10	209,00	51
302126 10	669,00	147

codice	€	pag
312126 10	839,00	147
371012 10	425,00	38
371015 10	375,00	39
371020 10	245,00	42
371021 10	150,00	42
371025 10	415,00	38
371096 10	530,00	39
372010 10	160,00	43
372011 10	123,50	43
372020 10	325,00	40
372026 10	275,00	40
372027 10	315,00	40
372030 10	160,00	41
372031 10	199,00	41
372038 10	212,00	41
372039 10	212,00	41
372062 10	300,00	44
372063 10	339,00	44
372064 10	352,00	45
372065 10	352,00	45
372132 10	179,00	46
372133 10	179,00	46
372134 10	179,00	47
372135 10	179,00	47
372910 10	160,00	43
373010 10	189,00	34
373011 10	175,50	34
373018 10	264,00	36
373038 10	244,00	35
373045 10	230,50	35
373077 10	299,00	36
373081 10	229,00	37
374010 10	195,00	37
374011 10	181,50	37
37E541 10	515,00	110
37E542 10	450,00	110
37E543 10	550,00	111
37E544 10	485,00	111
37E545 10	495,00	112
37E546 10	430,00	112
37E547 10	475,00	113
37E548 10	410,00	113

codice	€	pag
412410 10	379,00	26
412414 10	399,00	26
412425 10	419,00	26
412426 10	439,00	27
412427 10	494,00	27
412428 10	499,00	27
412500 10	219,00	28
412501 10	219,00	28
412502 10	219,00	28
412503 10	219,00	29
412504 10	219,00	29
412505 10	219,00	29
471010 10	107,70	105
471012 10	109,70	105
471015 10	91,70	105
471020 10	127,90	107
472010 10	57,90	107
472015 10	83,80	106
472020 10	101,80	106
473010 10	78,50	104
474010 10	79,50	104
481010 10	142,00	95
481012 10	152,00	95
481013 10	130,00	96
481015 10	112,00	97
481022 10	135,00	100
481027 10	40,00	100
481095 10	128,00	96
482012 10	65,00	101
482013 10	28,50	101
482015 10	94,00	99
482020 10	134,00	98
482097 10	112,00	98
482912 10	65,00	101
483010 10	94,00	92
483011 10	84,00	92
483018 10	164,00	93
483077 10	199,00	93
484010 10	96,00	94
484011 10	86,00	94
561012 10	310,00	62
561015 10	260,00	63



codice	€	pag	codice	€	pag	codice	€	pag	codice	€	pag	codice	€	pag
561020 10	175,00	66	962504 10	80,00	85	991645 10	110,00	196	992687 10	144,00	188	9930L4 10	50,00	201
561025 10	300,00	62	962505 10	80,00	85	991650 10	90,00	197	992688 10	174,00	189	9930L5 10	50,00	201
562010 10	95,00	66	962506 10	1.775,00	137	991651 10	110,00	197	992726 10	39,50	21	9930L6 10	63,00	201
562020 10	245,00	64	962514 10	1.979,00	140	991652 10	110,00	197	"	"	43	9930L7 10	50,00	201
562026 10	195,00	65	962516 10	995,00	136	991653 10	110,00	197	"	"	101	9930L8 10	68,00	201
562027 10	235,00	64	962519 10	1.600,00	141	991830 10	9,00	193	992727 10	99,00	20	9930L9 10	55,00	201
563010 10	159,00	56	990051 10	7,25	196	991855 97	4,50	192	"	"	42	9930M0 10	40,00	201
563011 10	145,50	56	990052 10	7,25	197	991855 98	4,50	192	"	"	100	9930M1 10	40,00	201
563013 10	250,00	59	990053 10	14,50	197	992077 10	329,50	191	992732 10	39,50	21			
563018 10	236,50	59	990054 10	5,25	197	992078 10	240,00	191	"	"	43	C000471 48	32,00	161
563038 10	225,00	58	990055 10	12,50	197	992080 10	74,90	190	"	"	101	C003011 00	270,00	167
563045 10	211,50	58	990220 99	23,50	198	992081 10	86,90	191	992739 10	126,00	24	C011171 00	310,00	170
563081 10	199,00	60	990247 99	75,00	199	9921D1 10	85,50	195	"	"	46	C014171 00	215,00	180
563083 10	169,00	57	990251 99	22,50	198	992112 10	69,00	79	992740 10	165,00	24	C014172 00	220,00	181
563084 10	155,50	57	990252 99	79,00	199	992211 99	5,00	200	"	"	46	C014173 00	275,00	182
564010 10	165,00	60	990253 99	30,50	198	992215 99	5,00	199	992744 10	178,00	25	C014175 00	270,00	183
564011 10	151,50	60	990261 99	55,00	198	992274 99	14,00	199	"	"	47	C019011 00	990,00	163
565020 10	270,00	150	990262 99	55,00	199	992307 02	5,00	198	992745 10	178,00	25	C019012 00	990,00	162
961158 10	245,00	80	990263 99	48,00	199	992308 10	7,50	199	"	"	47	C020011 00	535,00	165
961159 10	205,00	80	991006 10	10,00	194	992357 10	6,50	198	992771 10	165,00	28	C020012 00	535,00	164
962044 10	295,00	87	991007 10	15,00	194	992358 10	5,00	198	"	"	50	C023171 00	280,00	171
962046 10	355,00	87	991023 10	68,50	79	992359 10	7,50	198	"	"	84	C027071 00	270,00	179
962060 10	159,00	81	991031 10	15,00	195	992367 99	18,00	200	992772 10	185,00	28	C028072 00	290,00	178
962063 10	159,00	81	991044 10	118,00	195	992477 10	19,50	196	"	"	50	C032011 00	550,00	158
962066 10	219,00	81	991045 10	39,50	195	992478 10	25,50	196	"	"	84	C032022 00	1.050,00	159
962068 10	668,00	145	991046 10	49,00	194	992479 10	17,50	196	992773 10	205,00	28	C032311 00	530,00	161
962410 10	240,00	82	991054 10	29,50	194	992610 10	189,00	188	"	"	50	C032471 00	530,00	160
962414 10	260,00	82	991083 10	118,00	194	992627 10	219,00	189	"	"	84	C032871 00	152,00	160
962417 10	369,00	86	991085 10	5,00	194	992636 10	224,00	188	992774 10	280,00	29	C033171 00	250,00	174
962418 10	409,00	86	991205 10	20,00	190	992640 10	254,00	189	"	"	51	C034011 00	440,00	168
962425 10	280,00	82	991403 10	35,00	193	992648 10	35,00	195	"	"	85	C034012 00	620,00	169
962426 10	300,00	83	991410 10	17,50	193	992652 10	43,50	195	992775 10	225,00	29	C041171 00	260,00	175
962427 10	355,00	83	991412 10	30,00	192	992675 10	139,00	189	"	"	51	C042073 00	300,00	172
962428 10	360,00	83	991443 10	65,00	192	992676 10	159,00	190	"	"	85	C042071 00	355,00	172
962490 10	1.730,00	132	991444 10	65,00	193	992678 10	279,00	142	992776 10	285,00	29	C042172 00	410,00	173
962491 10	1.630,00	132	991449 10	35,00	192	992679 10	199,00	142	"	"	51	C044011 00	865,00	166
962492 10	1.810,00	133	991453 10	210,00	192	992680 10	379,00	143	"	"	85	C045171 00	365,00	176
962493 10	1.710,00	133	991454 10	210,00	193	992681 10	369,00	144	9930I9 10	50,00	200	C060171 00	630,00	177
962500 10	80,00	84	991457 10	20,00	193	992682 10	449,00	144	9930L0 10	55,00	200			
962501 10	80,00	84	991615 10	90,00	196	992683 10	399,00	146	9930L1 10	55,00	200			
962502 10	80,00	84	991620 10	110,00	196	992684 10	479,00	146	9930L2 10	55,00	200			
962503 10	80,00	85	991625 10	110,00	196	992686 10	109,00	188	9930L3 10	55,00	200			

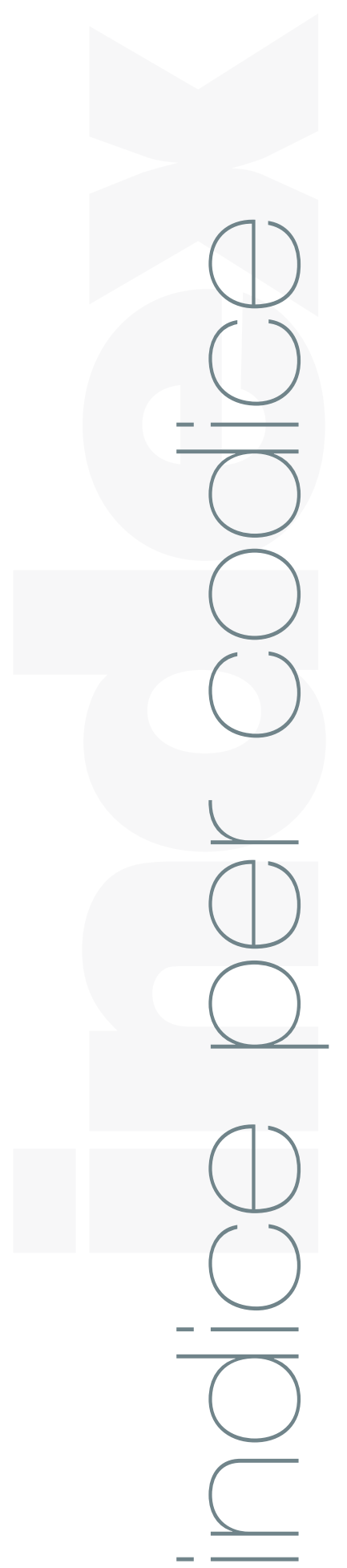

CONDIZIONI GENERALI DI VENDITA

Le presenti condizioni generali disciplinano tutti gli attuali e futuri contratti fra le parti, salvo eventuali deroghe specificatamente concordate per iscritto. Eventuali condizioni generali del compratore non troveranno applicazione nei rapporti futuri fra le parti se non espressamente accettate per iscritto dalla Palazzani Rubinetterie S.p.A.

Contratto

L'invio da parte del compratore di un ordine al venditore comporta l'applicazione al contratto di vendita delle presenti condizioni generali. Il venditore si riserva il diritto di accettare o rifiutare l'ordine ricevuto. Le offerte fatte da agenti, rappresentanti ed intermediari nominati dal venditore non sono per lui impegnative fino a quando non siano confermate dal venditore stesso.

Prezzi

Ai prezzi indicati nel presente listino deve essere applicata l'IVA secondo l'aliquota in vigore al momento della fatturazione. Il venditore si riserva di modificare i prezzi, o variare il listino prezzi senza alcun preavviso.

Modelli

Il venditore si riserva la facoltà di apportare senza nessun preavviso, modifiche ai modelli che riterrà opportune.

Resa della Merce

Salvo contrariamente pattuito, la fornitura dei prodotti si intende Franco Fabbrica del venditore: trasporto ed assicurazione sono pertanto a carico del compratore e ciò anche quando sia convenuto che la spedizione o parte di essa venga curata dal venditore, nel qual caso quest'ultimo agirà come mandatario del compratore, essendo inteso che il trasporto verrà effettuato a rischio del compratore.

I rischi relativi alla fornitura passano al compratore al momento in cui i prodotti lasciano lo stabilimento del venditore.

Termini di Consegna

I termini di consegna si intendono approssimativi a favore del venditore e comunque con un congruo margine di tolleranza. E' esclusa qualsiasi responsabilità del venditore per danni derivanti da anticipata, ritardata o mancata consegna, totale o parziale. Il compratore è sempre tenuto a prendere in consegna i prodotti, anche in caso di consegne parziali e quando i prodotti vengano consegnati prima o successivamente alla data di consegna stabilita. Il termine di consegna verrà prorogato di un periodo pari a quello della durata dell'impedimento al verificarsi di cause di forza maggiore. In nessun caso, a causa del verificarsi di tali circostanze, il compratore potrà esigere compensi o indennizzi di qualsiasi natura.

Garanzia

Il venditore garantisce la conformità dei prodotti forniti; con il termine di conformità dei prodotti si intende che essi corrispondono per qualità, quantità e tipo a quanto stabilito nel contratto e che sono esenti da vizi che potrebbero renderli non idonei all'uso cui sono destinati. La garanzia per vizi è limitata ai soli difetti dei prodotti conseguenti a difetti di progettazione, di materiale o di costruzione riconducibili al venditore, e non si applica nel caso in cui il compratore non provi di aver effettuato una corretta conservazione dei prodotti e di non averli modificati senza il consenso del venditore. Il venditore non risponde dei difetti di conformità dei prodotti dovuti all'usura normale di quelle parti che, per loro natura sono soggette a usura rapida e continua. La garanzia decade qualora i prodotti vengano sottoposti a pressioni superiori a quelle ammesse dalle norme europee: 5K/cm² e quando non vengono rispettate le raccomandazioni del produttore. La garanzia non copre i danni causati da acqua contenente corpi estranei.

Raccomandazioni del produttore

Si raccomanda l'installazione di un filtro centralizzato e la sua corretta manutenzione per non esporre la rubinetteria alle impurità dell'acqua. Si raccomanda l'installazione di riduttori di pressione nei casi in cui la pressione di esercizio superi i 5kg/cm². Per i miscelatori termostatici si raccomanda per un corretto utilizzo del rubinetto una temperatura di ingresso dell'acqua calda (65°C^o + - 5) come da norme UNI 1111. Per la pulizia delle superfici cromate, si raccomanda di non utilizzare acidi corrosivi soprattutto se contenenti acido cloridrico. Le finiture speciali devono essere pulite solo con acqua ed un panno morbido.

Reclami

Il compratore è tenuto a verificare la conformità dei prodotti e l'assenza di vizi. I reclami relativi a non conformità dei prodotti forniti dovranno essere effettuati, a pena di decadenza, entro e non oltre quindici giorni dal ricevimento della merce a destino. I vizi, difetti o non conformità occulti devono essere denunciati immediatamente alla loro scoperta e comunque, a pena di decadenza, entro e non oltre sei mesi dalla data di consegna. Tutti i reclami devono essere effettuati mediante lettera raccomandata indirizzata al venditore e devono indicare dettagliatamente i vizi e le non conformità contestate con prove documentali. La garanzia ha una durata di sei mesi.

Rimedi

In caso di Prodotti non conformi, e dopo aver ricevuto un rapporto dettagliato dal compratore, il venditore potrà, a sua insindacabile scelta:

- fornire gratuitamente Franco Fabbrica al compratore prodotti dello stesso genere e quantità di quelli risultanti difettosi o non conformi a quanto pattuito, oppure le sole parti difettose dello stesso dopo averne ottenuto la resa per la verifica. La eventuale sostituzione effettuata prontamente dal venditore non può essere ritenuta un implicito riconoscimento dei vizi contestati: detto riconoscimento dovrà essere sempre esplicito e conseguente al controllo del venditore sui prodotti contestati. Qualora il venditore, in sede di verifica, non riconosca viziati i prodotti, provvederà alla fatturazione di quelli inviati in sostituzione; oppure
 - emettere una nota di accredito a favore del compratore per un importo corrispondente al valore dei prodotti difettosi.
- In entrambi i casi il venditore ha diritto alla restituzione dei prodotti difettosi, che diventano di sua proprietà.

Limitazione di responsabilità del venditore

Salvo dolo o colpa grave del venditore l'eventuale risarcimento di qualsiasi danno al compratore non potrà comunque superare il prezzo di fattura dei prodotti contestati.

Pagamento

I pagamenti ed ogni altra somma dovuta a qualsiasi titolo al venditore si intendono netti al suo domicilio. Qualsiasi ritardo o irregolarità nel pagamento dà al venditore il diritto di sospendere le forniture o di risolvere contratti in corso, anche non relativi ai pagamenti in questione, nonché il diritto al risarcimento degli eventuali danni. Il venditore ha altresì il diritto a decorrere dalla scadenza del pagamento, agli interessi moratori nella misura stabilita in Italia dall'art. 5 del Decreto Legislativo 9 ottobre 2002, n. 231. Il ritardo nei pagamenti dà altresì al venditore il diritto di escludere la garanzia per tutto il periodo durante il quale il ritardo perdura.

Riserva di proprietà

I prodotti consegnati restano di proprietà del venditore sino al momento del completo pagamento del prezzo.

Legge applicabile e foro competente

Tutti i contratti disciplinati dalle presenti condizioni generali sono regolati dalla legge italiana. Per ogni controversia relativa o comunque collegata ai contratti cui si applicano le presenti condizioni generali è esclusivamente competente il foro del venditore; quest'ultimo avrà tuttavia facoltà di agire presso il foro del compratore.

GENERAL CONDITIONS FOR SALE

These general conditions regulate all present and future sales contracts between the parties, subject to any exceptions specifically agreed upon in writing. Any general conditions of the purchaser will not apply to future contractual relations between the parties unless expressly accepted in writing by Palazzani Rubinetterie S.p.A.

Formation of the Contract

The purchaser placing the order fully accepts the application of these general terms to the Contract for sale. Seller reserves the right to accept or refuse it. Offers made by Agents, Representatives or auxiliaries of the seller do not bind him until they are confirmed by the seller itself.

Prices

The prices indicated in this price list do not include V.A.T. or any other tax whatsoever. Seller may modify the prices / price list without prior notice.

Patterns

The supplier reserves the right of modifying the patterns and designs without any notice.

Surrender of the goods

Unless agreed to the contrary, the supply of the products is intended ex-factory: transport and insurance are therefore at the charge of the purchaser, this also when it is decided that the delivery or part of it will be taken care of by the seller, in which case the latter will act as the purchaser's agent, it being understood that the transport will be carried out at the expense and risk of the purchaser.

The risks relative to the supply pass to the purchaser, at the latest at the time in which the products leave the seller's plant.

Delivery terms

The delivery limits are agreed approximately in favour of the seller and not binding for him. Any liability of the seller is excluded for damage deriving from anticipated, delayed or non delivery, total or partial.

The purchaser is always held to take delivery of the products, even in the case of partial deliveries and even when the products are consigned before the established delivery date or successively to that date.

The seller shall not be deemed to be in breach of this agreement, or otherwise be liable to the purchaser, by reason of any delay in delivery, to the extent that the delay is due to any Force Majeure, and the time for performance of delivery shall be extended accordingly.

Guarantee

The seller guarantees the compliance of the products supplied; by the term compliance of the products it is meant that they correspond in quality, quantity and type to what was agreed in the contract and that they are without defects that could render them unfit for the use to which they are intended to be put. The guarantee against defects is limited only to product defects due to defects in planning, materials or construction that can be attributed to the seller, and does not apply in the case where the purchaser is unable to prove a correct preservation of the product and where he has modified them without the agreement of the seller. The seller is not liable for defects in product compliance due to the normal wear of those parts which, by nature, are subject to rapid and continuous wear and tear. The guarantee does not apply if the products are submitted to a water pressure higher than 5 Kg/cm² as suggested by European Specification. Also the guarantee does not apply in case the producer's recommendation are not respected. The guarantee does not cover damages caused by water containing foreign bodies.

Producer's recommendation

It is recommended to install a centralized filter, and carry the maintenance in order not to expose the taps and the mixer to the impurity of the water. It is recommended the installation of pressure reducers in cases where the working pressure is more than 5 Kg/cm². For the cleaning of the chromium plated surfaces, it is recommended not to use corrosive acids, especially if containing hydrochloric acids. Coatings other than chrome, the cleaning has to be done only with water and a soft cloth.

Claims

The purchaser is required to control the compliance of the products and the absence of flaws.

Claims relevant to non-conformities of the goods must be made, on pain of forfeiture, within and not later than fifteen days from the goods arrival at their place of destination. Hidden flaws, defect or non-compliances must be reported immediately after the discovery and in any event, on pain of forfeiture, not later than six months from the delivery date.

Claims must be made by registered letter, addressed to the seller and must describe in detail the flaws or disputed non-compliances. The guarantee is for a limited period of six months from delivery date.

Remedies

In case of faulty products and following to a report by the purchaser, the seller may at his discretion:

- supply ex-factory to the purchaser products of the same kind and quantity as those that proved not in compliance, on receiving returns for checking. Any replacement carried out promptly by the seller cannot be considered as implicit recognition of defects claimed: said recognition must always be explicit and following control by seller on goods challenged: should the seller, on controlling, find the goods in compliance, he will invoice for those sent in replacement; or
 - issue to the purchaser a credit-note in the amount equal to the value of the defective products.
- In both cases the purchaser shall return the faulty products to the seller.

Limit of the seller's liability

Except in the case of fraud or gross negligence on the seller's part, compensation of any damage to the purchaser will not, in any event, be greater than invoice price of the disputed products.

Payments

The payment and every other sum due to the seller, are understood as net at the registered office of the seller.

Any delay or irregularity in the payment gives the seller the right to suspend the supply or to cancel the contract in course, even if they are not relevant to the payments in question, as well as the right to compensation for eventual damages. The seller has also the right - starting from the payment deadline - to interests for delay as per art. 5 of Italian Legislative Decree no. 231 of 9/10/2002. The delays of payment likewise give the seller the right to exclusion from guarantee, for the whole period that the delay may persist.

Retention of Title

The delivered products remain the seller's property until the moment of the complete payment of the price.

Applicable Law and Competent Law-Court

All Contracts ruled by these general conditions are submitted to Italian Law. For any controversy relative to, or connected to the contractual products to which this general conditions apply, the seller's Law-Court has the exclusive competence; the latter, however, will have the opportunity to act also in the purchaser's Law-Court.



PALAZZANI

Palazzani Rubinetterie SpA

Via M. Anelli, 75/77 26020 Casalmorano (Cremona) Italy

tel +39.0374.74141 fax +39.0374.74524

info@palazzanirubinetterie.it www.palazzanirubinetterie.it